

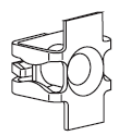







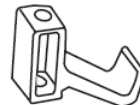

# Soft Tri-Fold Tonneau

## Installation parts Included:

 Drill Guide X2	 Box Nuts X4	 Backing Plates X8	 Bolts X12	 Stationary Clamps Hooks X2	 Driver Side Rail (3 notches) x1   Soft Tri-Fold Tonneau Cover x1   Passenger Side Rail (2 notches) x1
--	---	---	---	--	--

## Tools Required:

 T30 Torx	 7/16" Deep Socket	 Drill	 7.0mm (9/32") drill bit	<ul style="list-style-type: none"> <li>Identify truck bed attachment points (Step 1)</li> <li>Drill plastic rail cap at attachment points (Step 3 and Step 4)</li> </ul>
--	--	--	--	--

## Installation Instructions:

Read all instructions before proceeding. It is recommended that two people install the tonneau cover.

### Step 1:

Locate truck bed attachment points for driver side and passenger side rails. Attachment points are holes in truck bed sheet metal behind the plastic rail cap, composite liner behind the plastic rail cap.

### Step 2:

Install a Box Nut in each of the four (4) corner pillar positions. Box nuts are inserted in truck bed sheet metal as shown below. Access corner pillar holes by pulling back the plastic rail caps. Press box nuts in place so they are flush with the sheet metal.

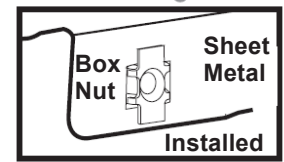
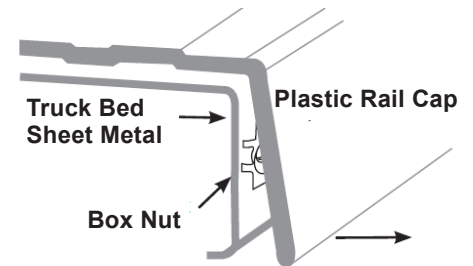
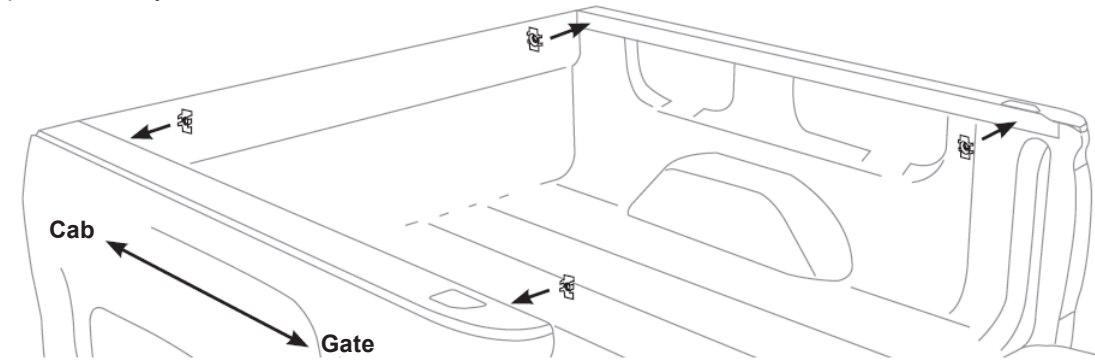
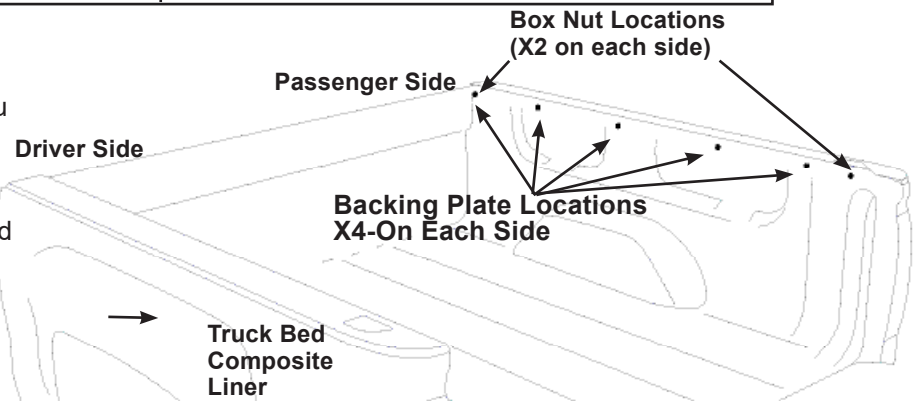

### Step 3:

After installing the box nuts lift the plastic rail cap and locate the Box Nut thread inlet with the drill guide. Drill through the plastic rail cap with 7.0mm (9/32") drill bit. Repeat for all four (4) corners.

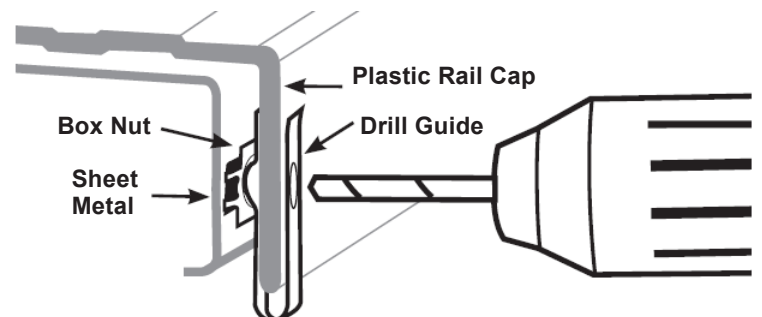

**Installation Instructions (Cont):**

**Step 4:**

Lift the plastic rail cap and locate backing plate attachment holes with the drill guide. Drill through the plastic rail cap with 7.0mm (9/32") drill bit. Repeat for all eight (8) backing plate locations.

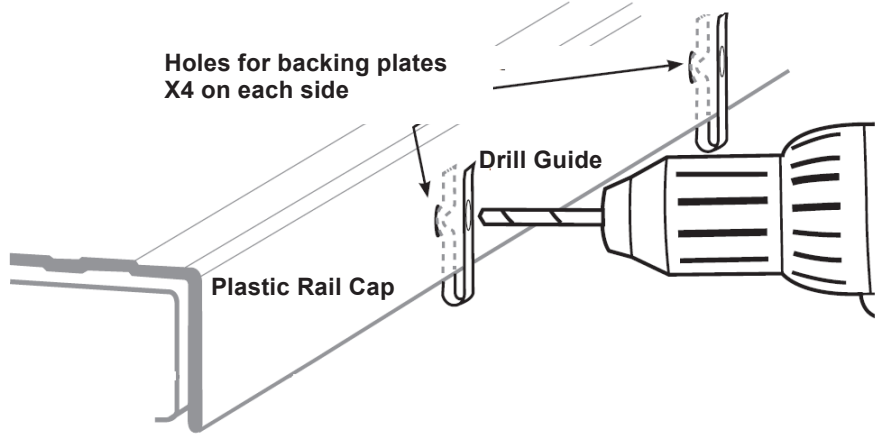

**Side Rail Installation:**

**Step 5: Driver side rail (A) has three (3) notches. Passenger side rail (B) has two (2) notches.**

Install driver side rail (A) in the order shown. Hand-tighten attachment bolt 1 and 2 in box nuts. Hand-tighten 3, 4, 5 and 6 into backing plates. Align the edge of the rail seal with the top of the plastic trim cap as shown in figure A. Use T30 Torx to fully tighten bolts 3, 4, 5 and 6 followed by bolts 1 and 2 to **8.7 N-m**.

Repeat for passenger side rail (B).

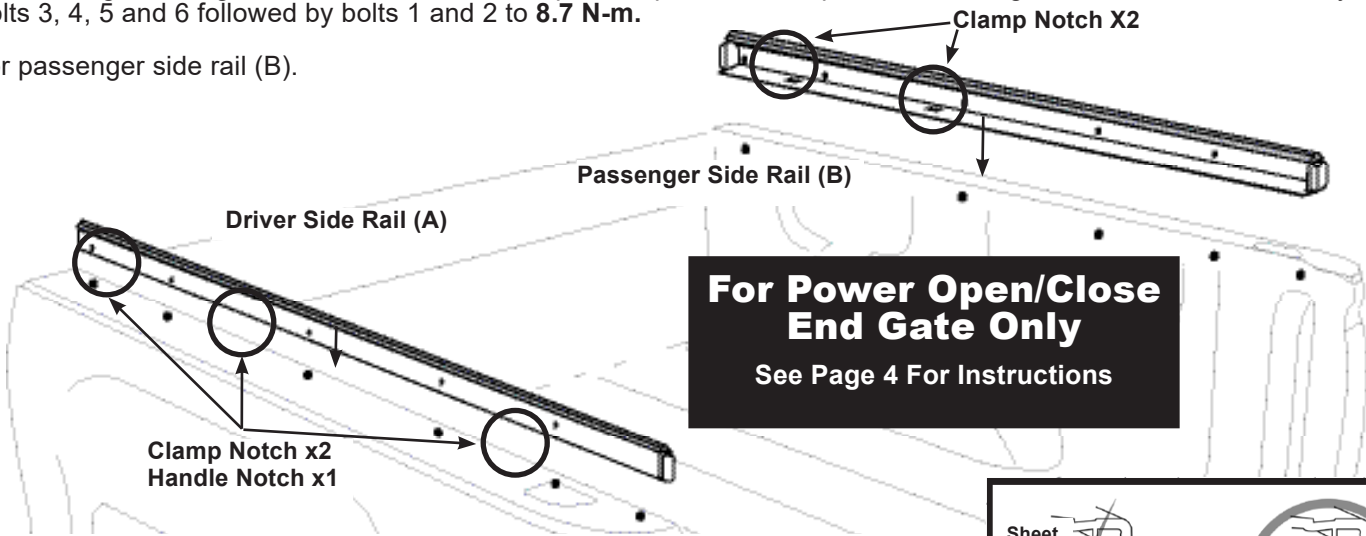

Backing plates are installed on the back side of the sheet metal. **DO NOT** install backing plates between plastic trim caps and sheet

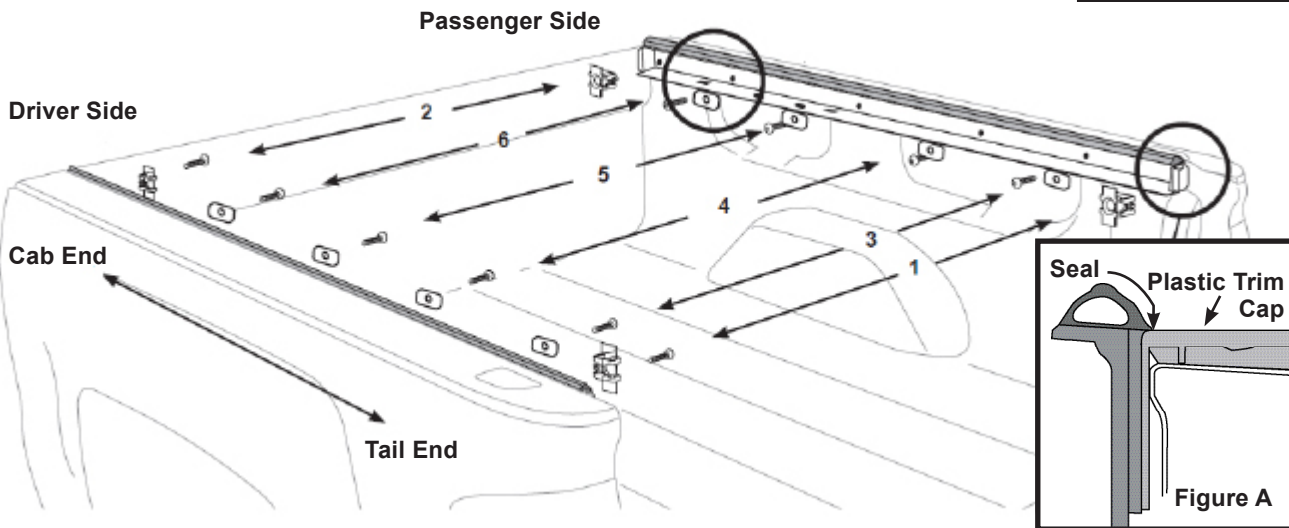
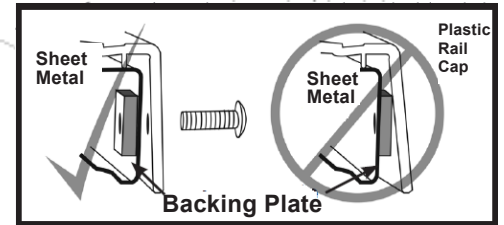

**Cover Installation**

**Step 6:**

Locate the rectangular notch in the driver and passenger side rails closest to the cab wall of the truck bed. Align the stationary clamps to the rectangular notch. Position the cover evenly side to side and rest the cab seal smoothly along the cab wall of the bed. Position the stationary clamps so that the hook rests inside the rectangular notch in the rail. Tighten the nut. Be sure to tighten each side evenly. Tighten only until Tonneau cannot shift from its position. **DO NOT OVER TIGHTEN.** Over tightening of nut can cause failure to clamping system. Be sure to clip safety tether to hole in rail from top down for ease of removal.

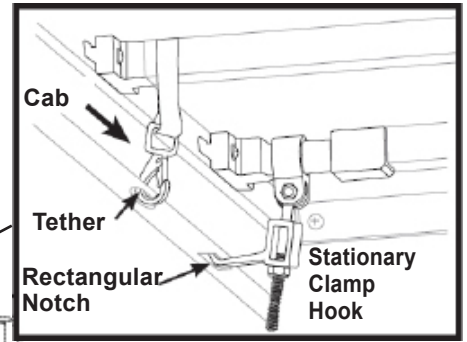

**Step 7:**

Unclip the tie down straps and unfold the tonneau. The tailgate must be open when closing tonneau cover.

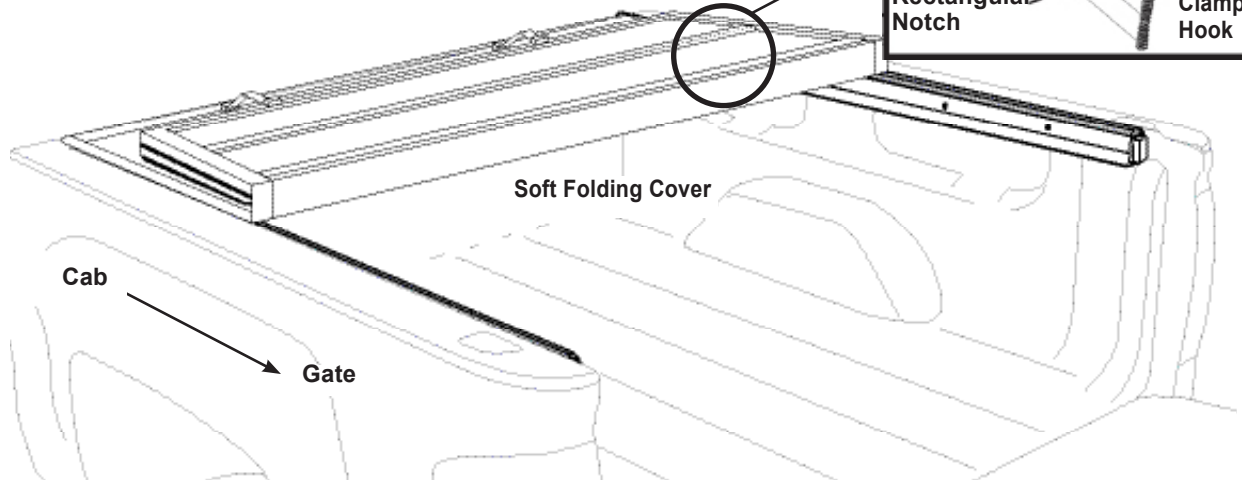

**Cover Installation (Cont.)**

**Step 8:**

With both hands, press down on the rear bar until the rear slam latches engage driver side and passenger side rails.

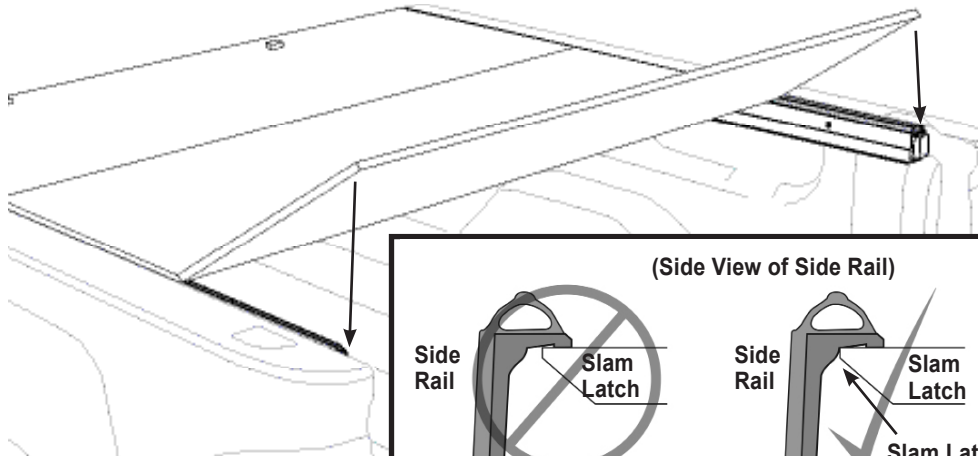

**Cover Installation (Cont)**

**Step 9 (optional):**

If the slam latches do not engage or there is excessive slack in the latches, adjust latches in or out and up or down.

To adjust, loosen the four (4) screws. To move the latches in or out, move the metal latch plate. To move the latches up or down, move the plastic adjuster tab. Tighten the four (4) screws. Repeat Step 8.

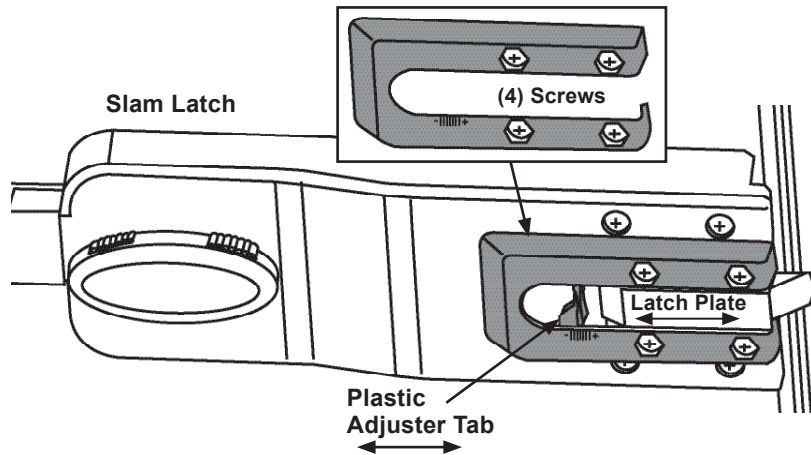

# For Power Open / Close End Gate Only

Tonneau Cover Side Rails Must Be Adjusted to Full Up Position and Cover Assembly Must Be Adjusted to Full Forward Position - To Ensure Proper Powered End Gate Closure to Fully Latched Position

During Step 5: While tightening each bolt to attach the rails, pull up and forward on the rails. Follow the installation sheet for bolt tightening sequence.

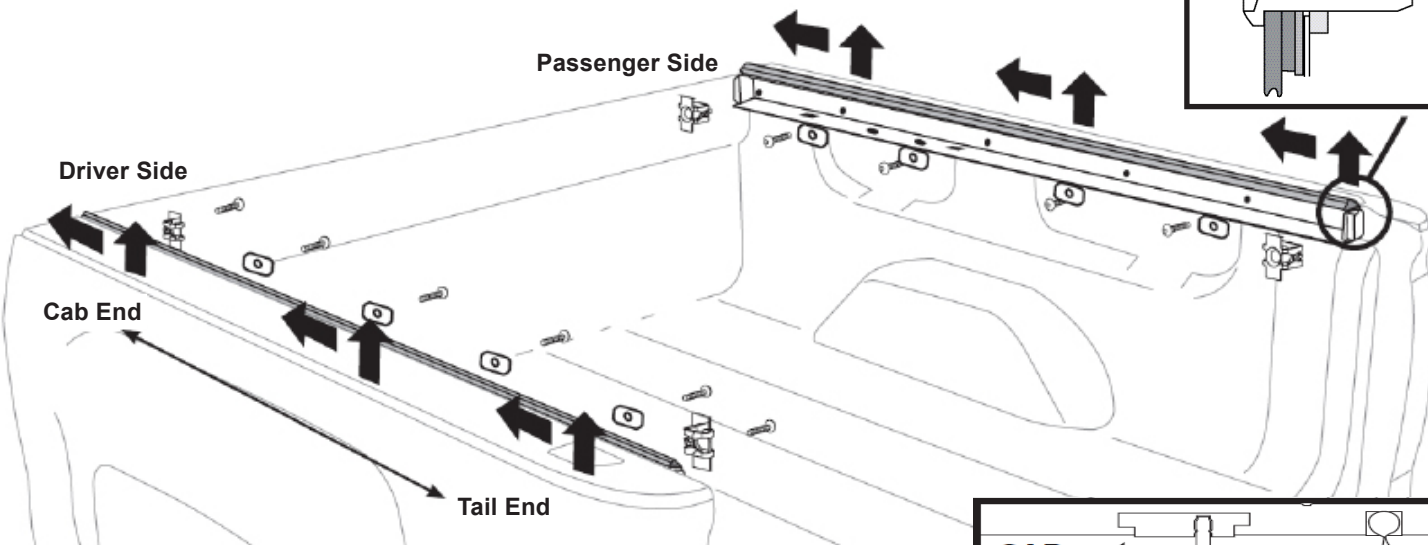
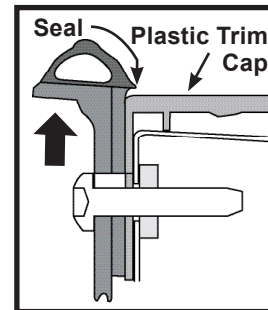

When positioning the cover, align the stationary clamp hook to the forward most portion of the notch, closest to the cab.

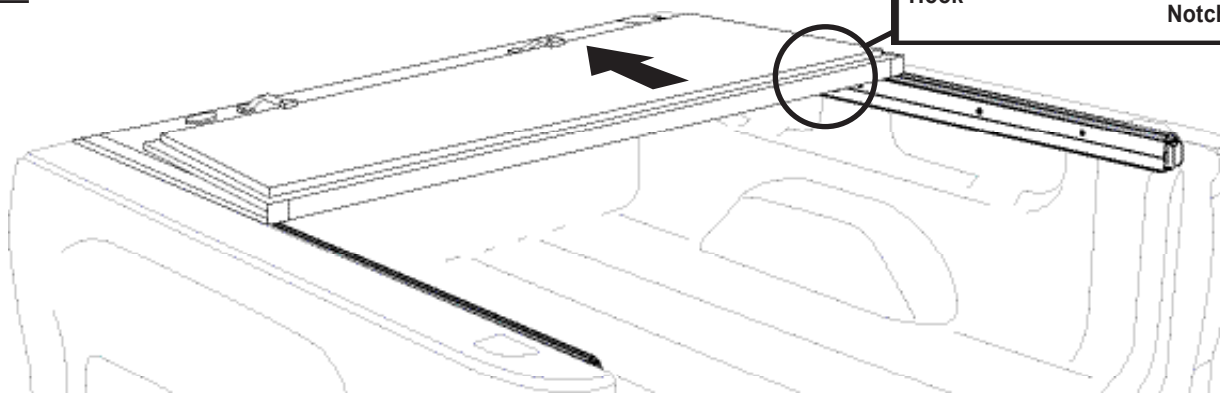
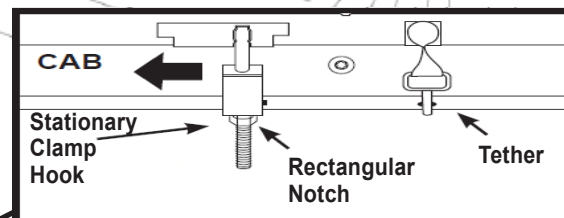



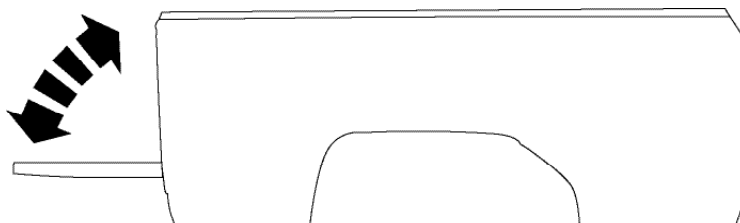



Cycle end gate no less than 5 times to assure proper function. +5X

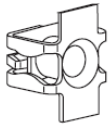

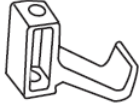

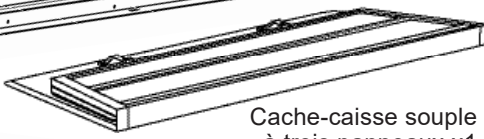

# Cache-caisse souple à trois panneaux

## Pièces d'installation incluses :

<p>Guide de perçage</p>  <p>X2</p>	<p>Écrous borgnes</p>  <p>X4</p>	<p>Plaques d'appui</p>  <p>X8</p>	<p>Boulons</p>  <p>X12</p>	<p>Crochets de serrage fixes</p>  <p>X2</p>	<p>Longeron côté conducteur (3 encoches) x1</p>  <p>Cache-caisse souple à trois panneaux x1</p>  <p>Longeron côté passager (2 encoches) x1</p> 
---	---	--	---	--	--

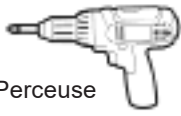
## Outils nécessaires :

<p>Torx T30</p> 	<p>Douille profonde de 7/16 po</p> 	<p>Perceuse</p> 	<p>Foret 7,0 mm (9/32 po)</p> 	<ul style="list-style-type: none"> <li>Déterminer les points de fixation de la caisse de camionnette (Étape 1)</li> <li>Percer le capuchon de longeron en plastique aux points de fixation (Étape 3 et étape 4)</li> </ul>
--	--	---	---	--

## Directives d'installation :

Lire l'ensemble des directives avant de procéder. Il est recommandé que deux personnes procèdent à la pose du cache-caisse.

### Étape 1 :

Rechercher les points de fixation de la caisse de camionnettes des longerons du côté conducteur et côté passager. Les points de fixation sont des trous dans la tôle de la caisse de camionnette derrière le bouchon de longeron en plastique et derrière la doublure en matériau composite.

### Étape 2 :

Poser un écrou borgne à chacune des quatre (4) positions de montant de coin. Les écrous borgnes s'insèrent dans la tôle de caisse de camionnette, comme indiqué ci-dessous. Pour accéder aux trous de montant de coin, tirer vers l'arrière les capuchons de longeron en plastique. Presser les écrous borgnes en place de façon à ce qu'ils affleurent la tôle.

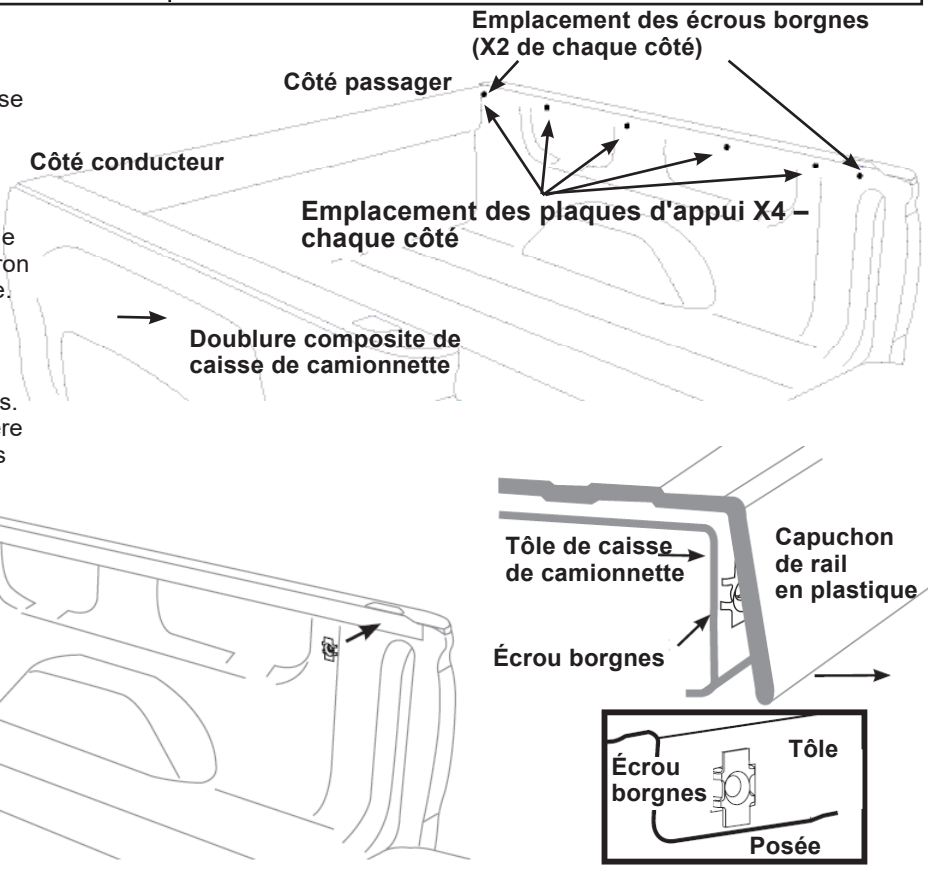

### Étape 3 :

Une fois les écrous borgnes posés, soulever le capuchon de longeron en plastique et positionner l'entrée du filetage de l'écrou borgne avec le guide de perçage. Percer à travers le capuchon de longeron en plastique avec un foret de 7,0 mm (9/32 po). Répéter la procédure pour les quatre (4) coins.

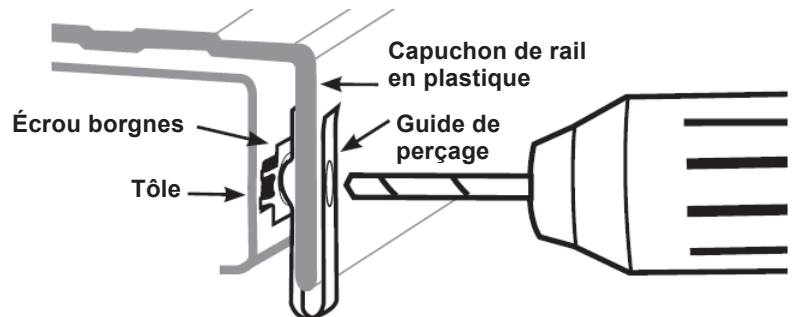

**Directives d'installation (suite) :**

**Étape 4 :**

Soulever le capuchon de longeron en plastique et déterminer les trous de fixation de plaque d'appui avec le guide de perçage. Percer à travers le capuchon de longeron en plastique avec un foret de 7,0 mm (9/32 po). Répéter la procédure pour les huit (8) emplacements de plaque d'appui.

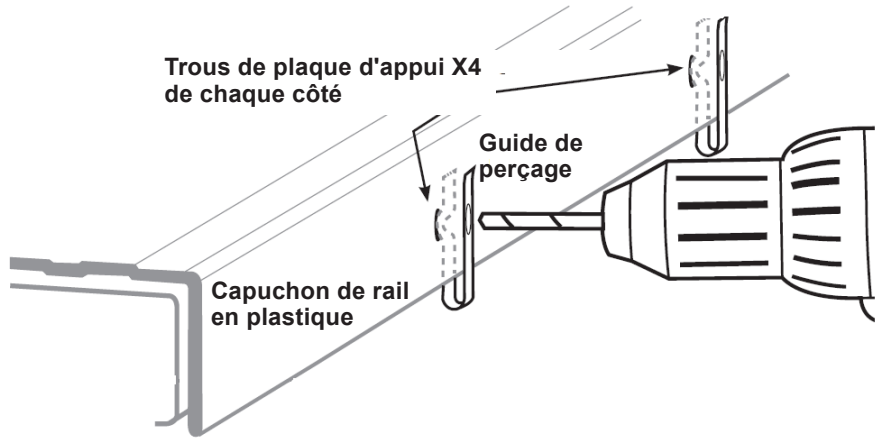

**Pose de longeron :**

**Étape 5 : Le longeron côté conducteur (A) est doté de trois (3) encoches. Le longeron côté passager (B) est doté de deux (2) encoches**

Poser le longeron côté conducteur (A) dans l'ordre indiqué. Serrer à la main les boulons de fixation 1 et 2 dans les écrous borgnes. Serrer à la main les boulons 3, 4, 5 et 6 dans les plaques d'appui. Aligner le bord du joint d'étanchéité de longeron avec le dessus du capuchon de garniture en plastique, comme indiqué à la figure A. Utiliser un embout Torx T30 pour serrer complètement les boulons 3, 4, 5 et 6, suivis des boulons 1 et 2 à **8,7 Nm**.

Répéter la procédure pour le longeron du côté passager (B).

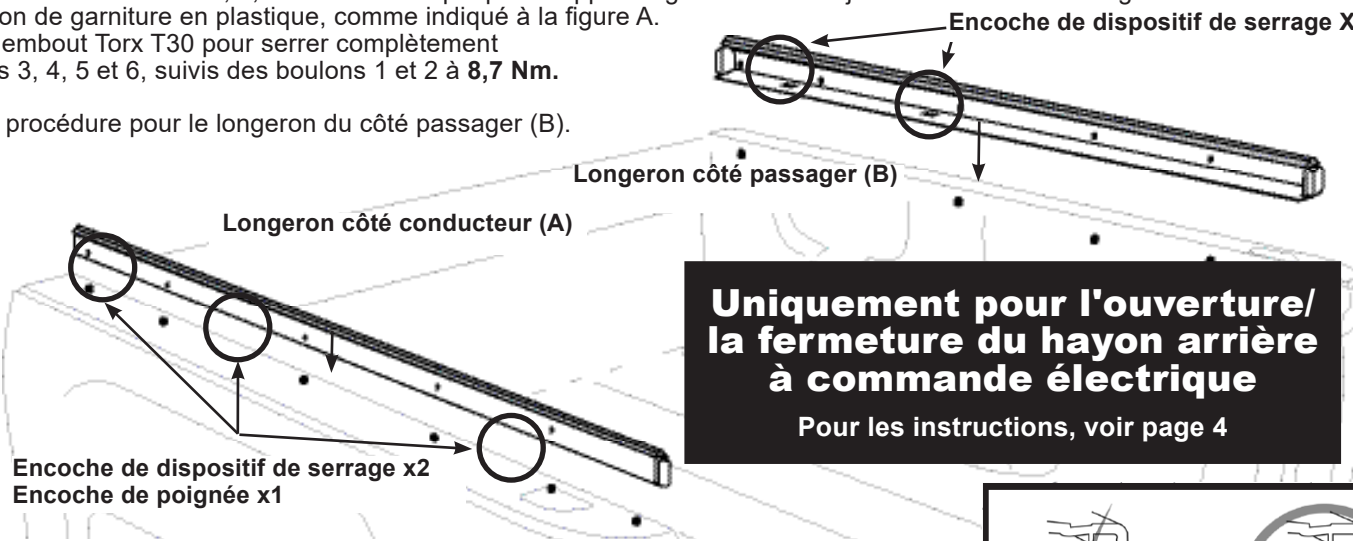

Encoche de dispositif de serrage x2  
Encoche de poignée x1

Les plaques d'appui se posent à l'endos de la tôle.  
NE PAS poser les plaques d'appui entre les capuchons de garniture en plastique et la tôle.

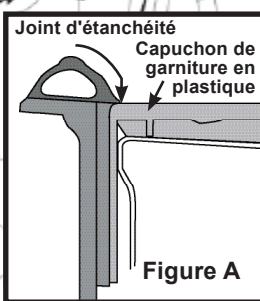
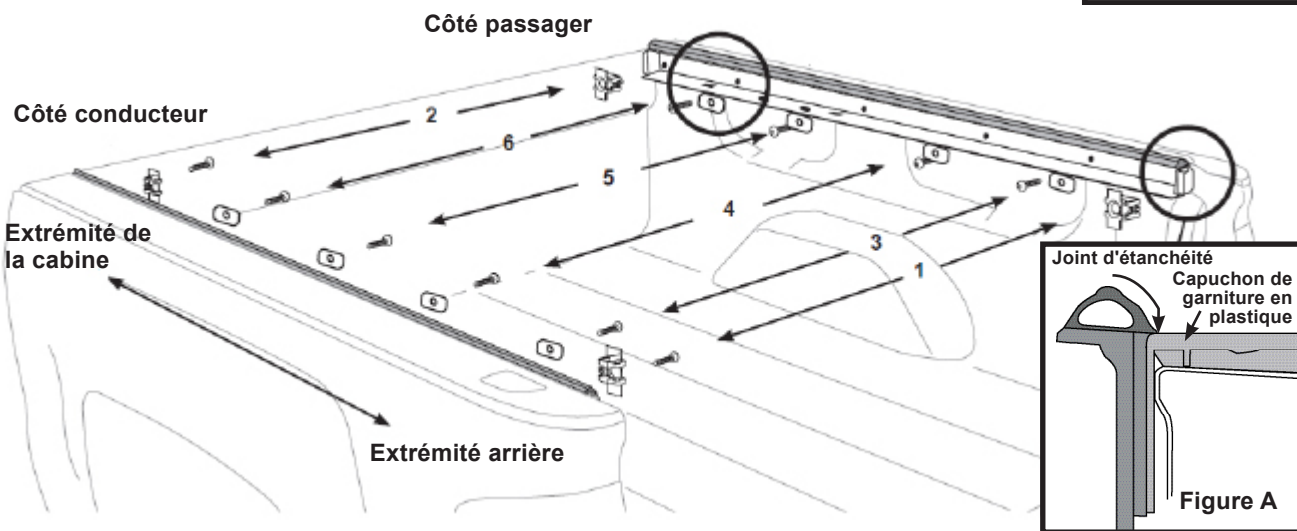
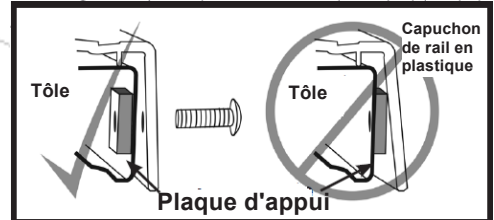

**Pose du couvercle**
**Étape 6 :**

Rechercher l'encoche rectangulaire sur les longerons côté conducteur et côté passager le plus près de la paroi côté cabine de la caisse de camionnette. Aligner les dispositifs de serrage fixes avec l'encoche rectangulaire. Disposer le cache-caisse uniformément d'un côté à l'autre et déposer soigneusement le joint d'étanchéité de cabine le long de la paroi côté cabine de la caisse. Positionner les dispositifs de serrage fixes de manière que le crochet demeure à l'intérieur de l'encoche rectangulaire dans le longeron. Serrer l'écrou. S'assurer de serrer chaque côté uniformément. Serrer uniquement jusqu'à ce que le cache-caisse ne puisse pas se déplacer. **NE PAS TROP SERRER.** Le fait de trop serrer l'écrou peut endommager le système de serrage. S'assurer d'engager la sangle de sûreté dans le trou du longeron de haut en bas pour faciliter le retrait.

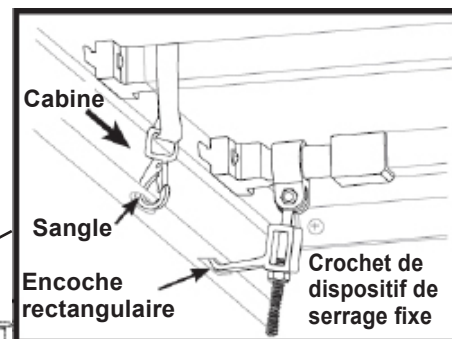
**Étape 7 :**

Dégager les sangles d'attache et enrôler le cache-caisse. Le hayon doit être ouvert pour la fermeture du cache-caisse.

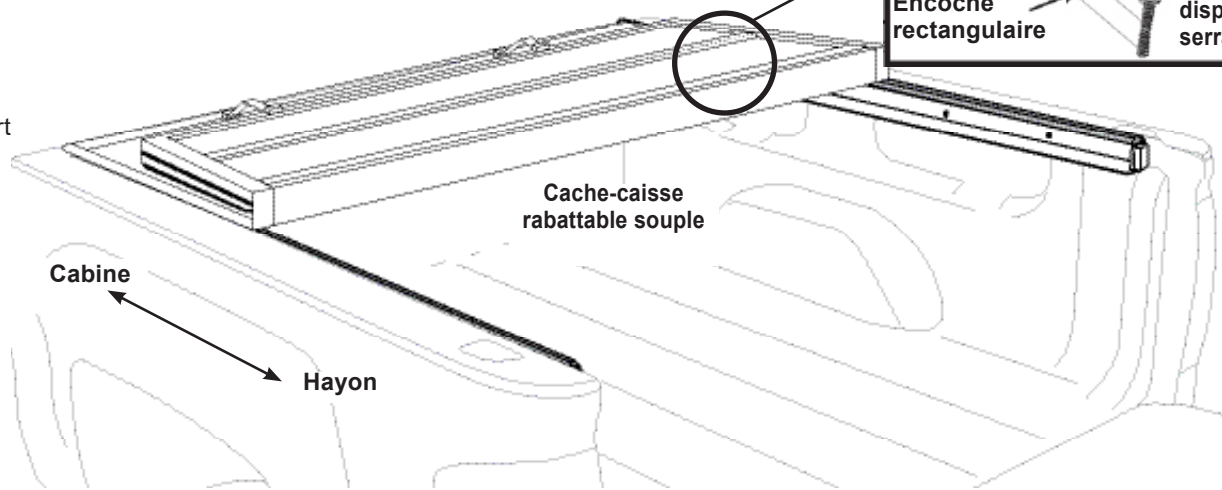

**Installation du couvercle (suite)**
**Étape 8 :**

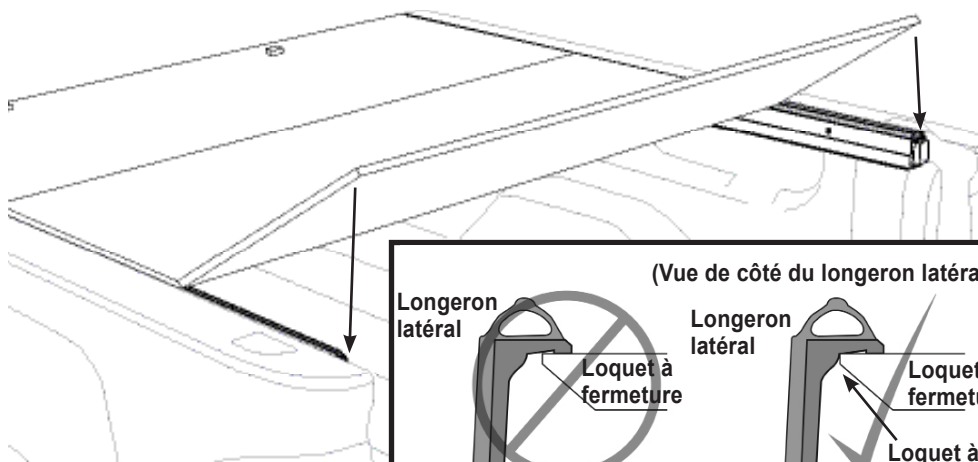
Utiliser les deux mains pour presser la barre arrière jusqu'à ce que les loquets à fermeture arrière s'engagent dans les longerons du côté conducteur et du côté passager.

**Installation du couvercle (suite)**
**Étape 9 (facultative) :**

Si les loquets à fermeture ne s'engagent pas ou s'ils présentent un jeu excessif, régler les loquets vers l'extérieur ou l'intérieur, puis vers le haut ou vers le bas.

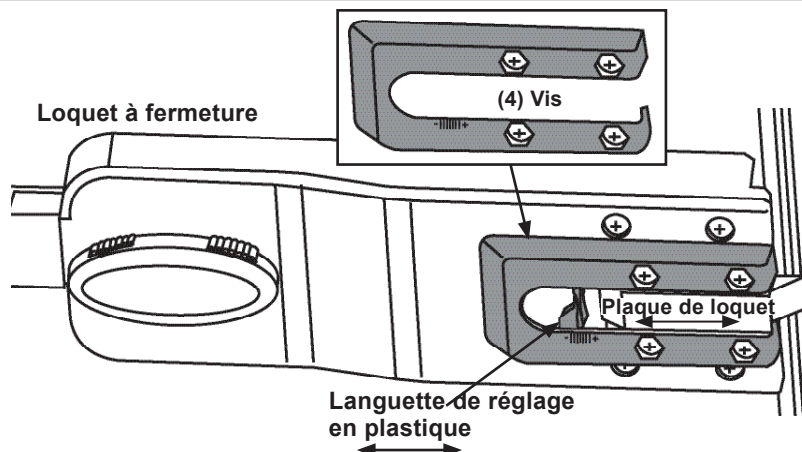
Pour effectuer le réglage, desserrer les quatre (4) vis. Pour déplacer les loquets vers l'intérieur ou l'extérieur, déplacer la plaque de loquet en métal. Pour déplacer les loquets vers le haut ou vers le bas, déplacer la languette de réglage en plastique. Serrer les quatre vis (4). Répéter l'étape 8.



# Uniquement pour l'ouverture / la fermeture du hayon arrière à commande électrique

Les rails latéraux du cache-caisse doivent être réglés en position complètement relevée et l'ensemble du cache doit être réglé en position complètement avancée, afin de garantir la fermeture correcte du hayon à commande électrique en position complètement verrouillée.

Lors de l'étape 5 : en serrant chaque boulon pour fixer les rails, tirer les rails vers le haut et vers l'avant. Suivre la feuille de montage pour l'ordre de serrage des boulons.

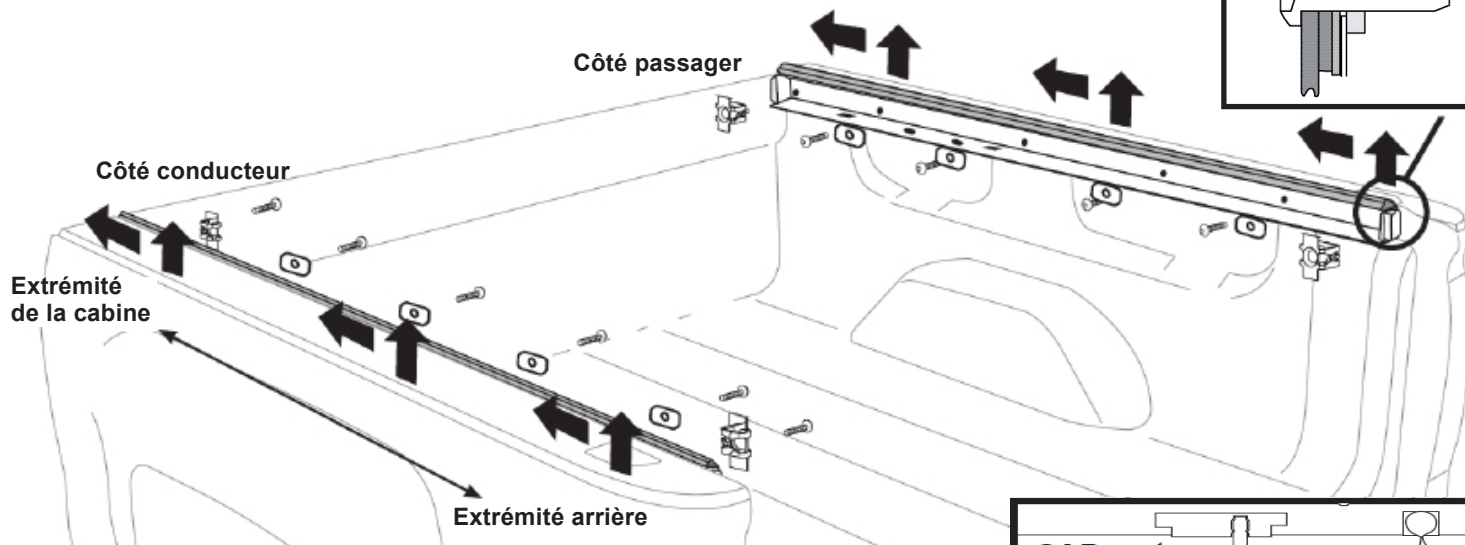
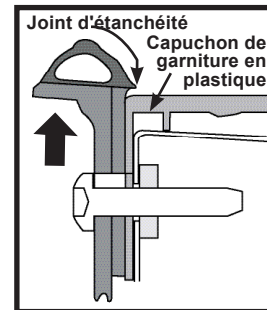

En positionnant le cache, aligner le crochet fixe dans la partie la plus avancée de l'encoche, la plus proche de la cabine.

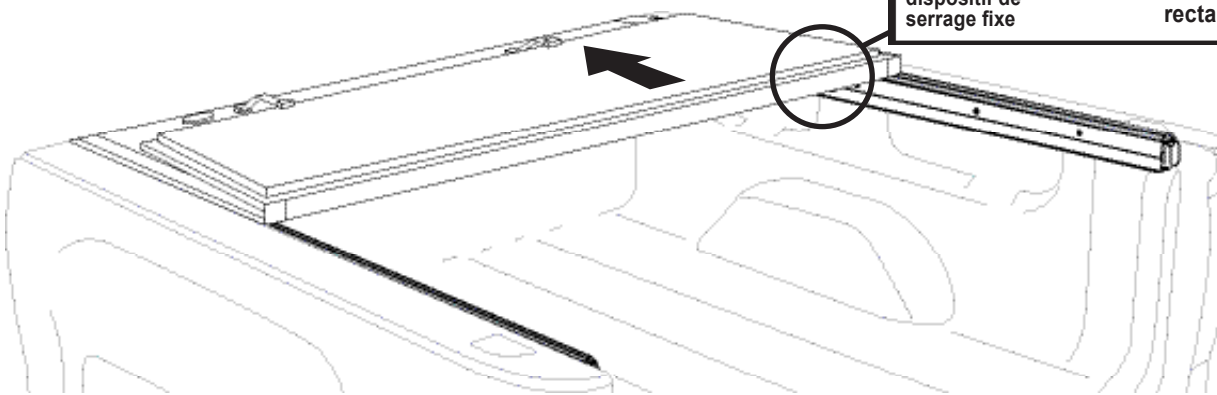
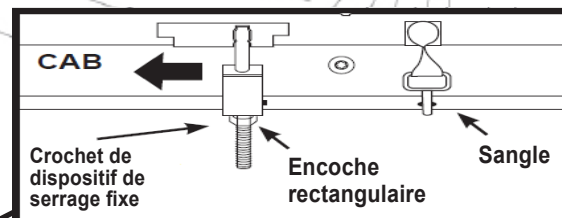

Actionner le hayon sur 5 cycles, au minimum, afin de garantir le fonctionnement correct.



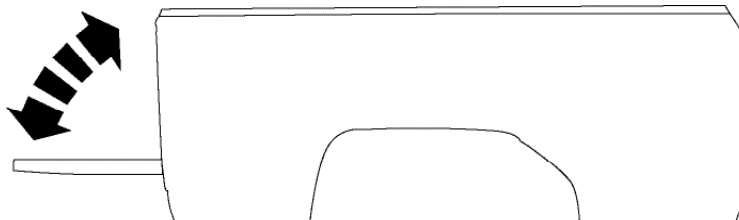



+5X



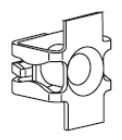



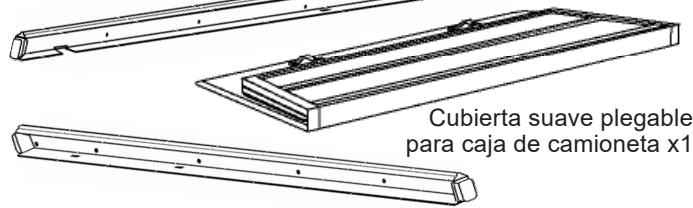

# Cubierta suave plegable para caja de camioneta

## Partes de instalación incluidas:

Guía para taladrar  X2	Tuercas de caja  X4	Placas posteriores  X8	Tornillos  X12	Ganchos de abrazaderas estacionarias  X2	Riel del lado del conductor (3 muescas) x1  Cubierta suave plegable para caja de camioneta x1  Riel del lado del pasajero (2 muescas) x1 
---	--	---	---	---	--

## Herramientas requeridas:

Torx T30 	Dado de 7/16" de profundidad 	Taladro 	Broca de 7.0 mm (9/32") 	<ul style="list-style-type: none"> <li>Identificar los puntos de fijación de la caja de la camioneta (Paso 1)</li> <li>Perforar la tapa de riel de plástico en los puntos de fijación (Paso 3 y Paso 4)</li> </ul>
--	---	--	--	--

## Instrucciones de Instalación:

Lea todas las instrucciones antes de continuar. Se recomienda que dos personas instalen la cubierta para caja de camioneta.

### Paso 1:

Localice los puntos de fijación en la caja de la camioneta para los rieles del lado del conductor y del lado del pasajero. Los puntos de conexión son orificios en el metal de lámina de la plataforma de la camioneta detrás del revestimiento compuesto de la tapa del riel de plástico detrás de la tapa del riel de plástico.

### Paso 2:

Instale una tuerca de caja en cada una de las cuatro (4) posiciones del poste de esquina. Las tuercas de caja se insertan en la lámina de la caja de la camioneta como se muestra enseguida. Acceda a los orificios del poste de esquina jalando hacia atrás las tapas de riel de plástico. Oprima las tuercas de caja encajándolas en su lugar para que queden al ras de la lámina.

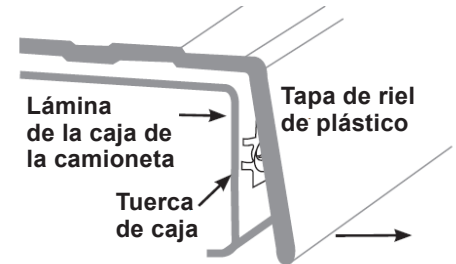
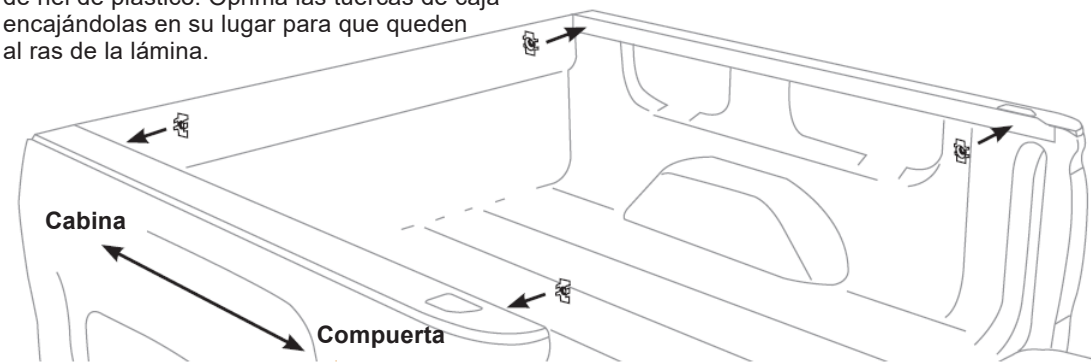

### Paso 3:

Después de instalar las tuercas de caja, levante la tapa de riel de plástico y localice la entrada de la rosca de la tuerca de caja con la guía para taladrar. Perfore a través de la tapa de riel de plástico con una broca de 7.0 mm (9/32"). Repita para las cuatro (4) esquinas.

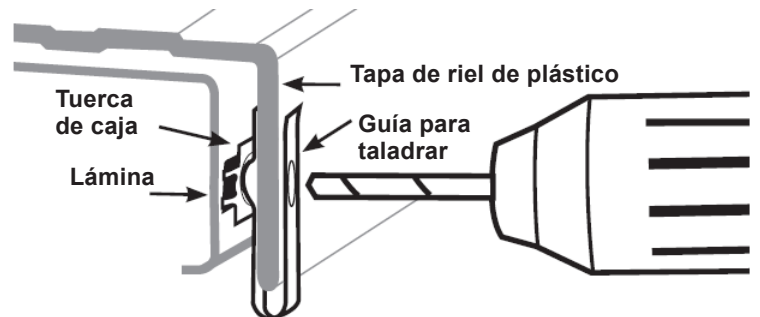

**Instrucciones de instalación (Continuación):**

**Paso 4:**

Levante la tapa de riel de plástico y localice los orificios de fijación de placa posterior con la guía para perforar. Perfore a través de la tapa de riel de plástico con una broca de 7.0 mm (9/32"). Repita para las ocho (8) ubicaciones de placa posterior.

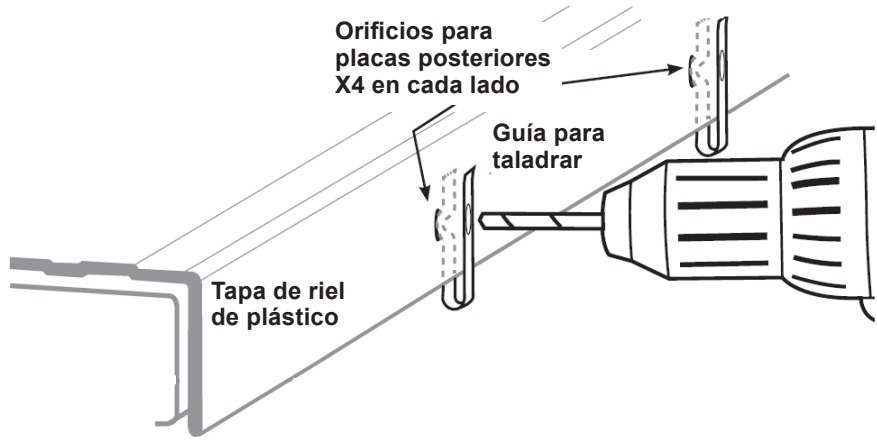

**Instalación de riel lateral:**

**Paso 5: El riel del lado del conductor (A) tiene tres (3) muescas. El riel del lado del pasajero (B) tiene dos (2) muescas.**

Instale el riel del lado del conductor (A) en el orden que se muestra. Apriete a mano el perno de fijación 1 y 2 en las tuercas de caja. Apriete a mano 3, 4, 5 y 6 en las placas posteriores. Alinee el borde del sello del riel con la parte superior de la tapa decorativa de plástico como se muestra en la figura A. Use un destornillador Torx T30 para apretar completamente los pernos 3, 4, 5 y 6 seguidos por los pernos 1 y 2 a **8.7 N-m**.

Repita para el riel del lado del pasajero (B).

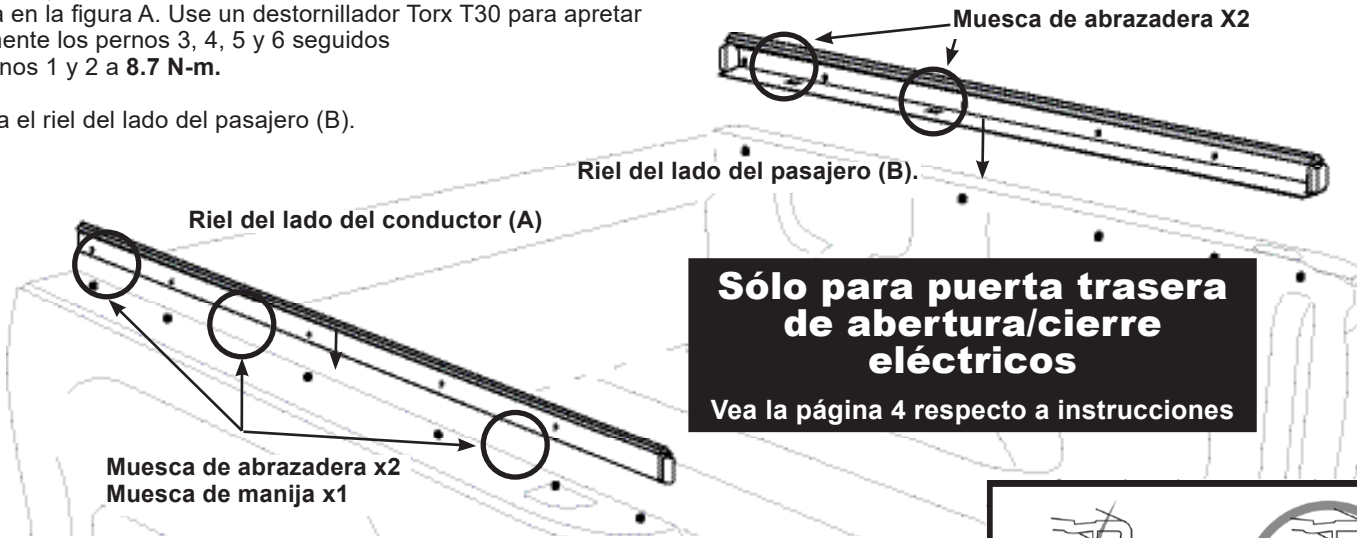

Las placas posteriores van instaladas en el lado de atrás de la lámina. NO instale las placas posteriores entre las tapas decorativas de plástico y la lámina.

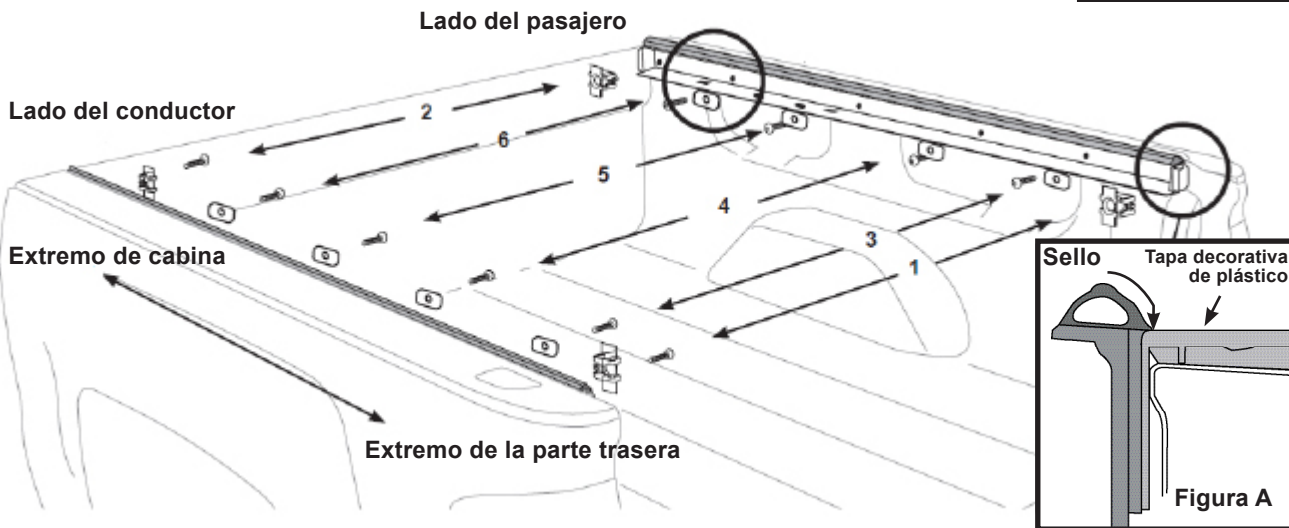
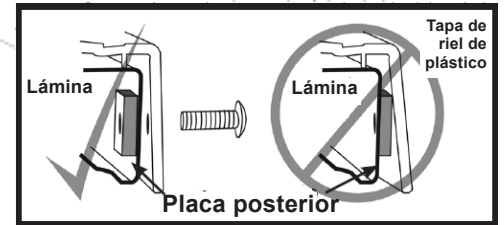

**Instalación de cubierta**

**Paso 6:**

Localice la muesca rectangular en los rieles del lado del conductor y del pasajero que esté más cerca de la pared de cabina de la caja de camioneta. Alinee las abrazaderas estacionarias con la muesca rectangular. Posicione la cubierta en forma uniforme entre un lado y otro y coloque el sello de cabina suavemente a lo largo de la pared de cabina de la caja. Coloque las abrazaderas estacionarias de modo que el gancho descansa dentro de la muesca rectangular en el riel. Apriete la tuerca. Asegúrese de apretar cada lado en forma uniforme. Apriete sólo hasta que el Tonneau no se pueda mover de su posición. **NO APRIETE EN EXCESO.** Apretar en exceso la tuerca puede causar falla al sistema de sujeción. Asegure sujetar la correa de seguridad al orificio en el riel de arriba hacia abajo para facilitar su remoción.

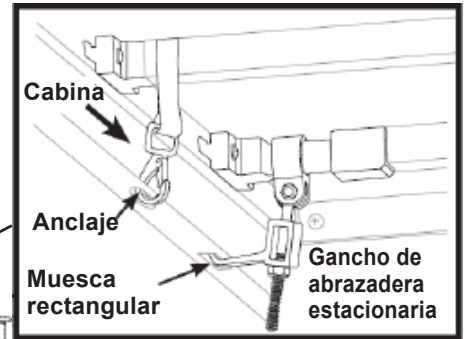

**Paso 7:**

Desenganche las correas de amarre y desdoble la cubierta. La compuerta trasera debe estar abierta cuando se cierra la cubierta tonneau.

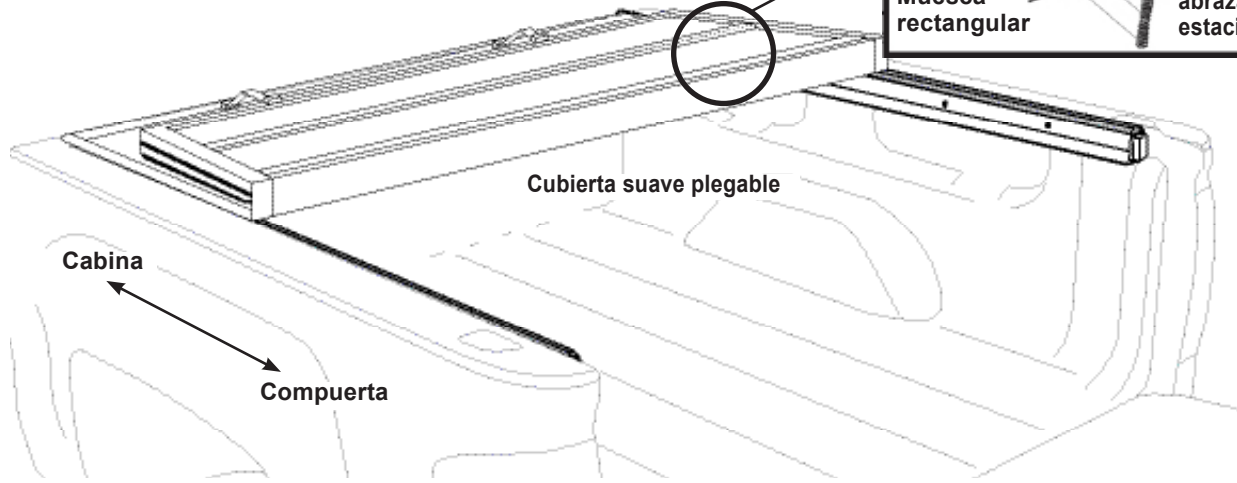

**Instalación de cubierta (continuación.)**

**Paso 8:**

Con ambas manos, oprima la barra trasera hasta que los cierres de resbalón traseros enganchen en los rieles del lado del conductor y del pasajero.

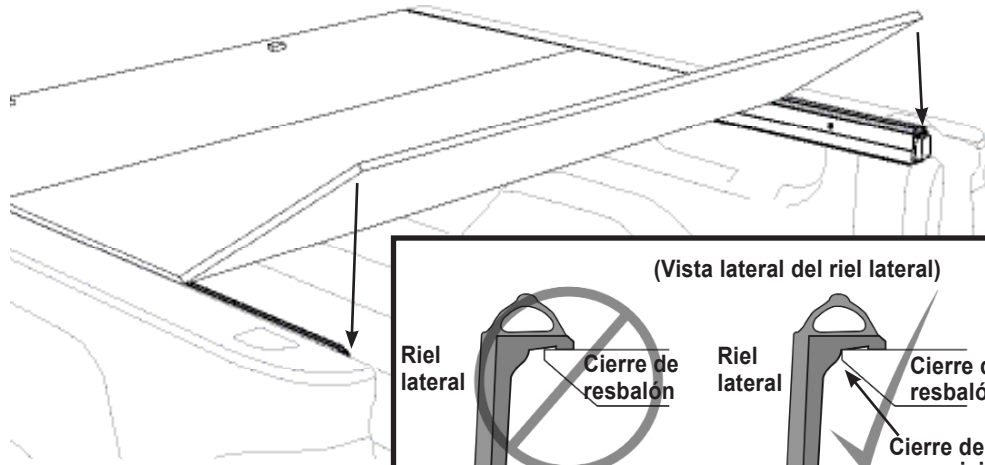

**Instalación de cubierta (continuación)**

**Paso 9 (opcional):**

Si los cierres de resbalón no enganchan o hay una holgura excesiva en los cierres, ajústelos hacia adentro o hacia afuera y hacia arriba o hacia abajo.

Para ajustar, afloje los cuatro (4) tornillos. Para mover los cierres hacia adentro o hacia afuera, mueva la placa de cierre metálica. Para mover los cierres hacia arriba o hacia abajo, mueva la lengüeta ajustadora de plástico. Apriete los cuatro (4) tornillos. Repita el Paso 8.

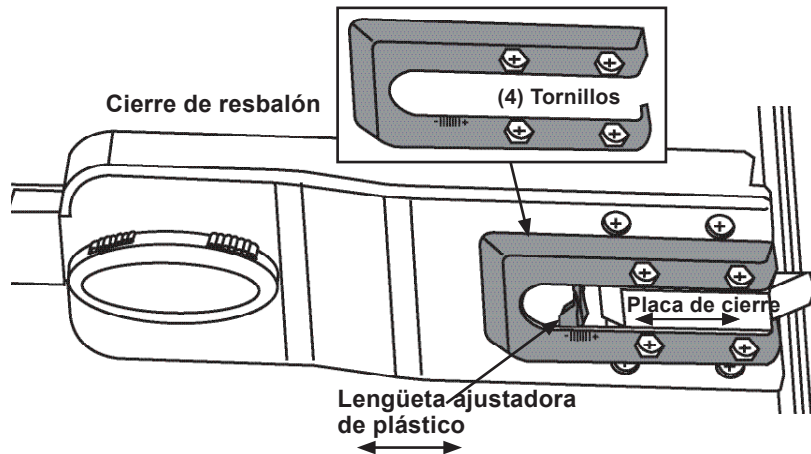

# Sólo para puerta trasera de apertura/cierre eléctricos

Los rieles laterales de la cubierta Tonneau se deben ajustar a la posición completamente arriba y el ensamble de la cubierta se debe ajustar a la posición completamente al frente -  
Para asegurar el cierre adecuado de la puerta trasera eléctrica a la posición completamente asegurada

Durante el Paso 5: Mientras aprieta cada perno para sujetar los rieles, jale hacia arriba y al frente sobre los rieles. Siga la hoja de instalación respecto a la secuencia de apriete.

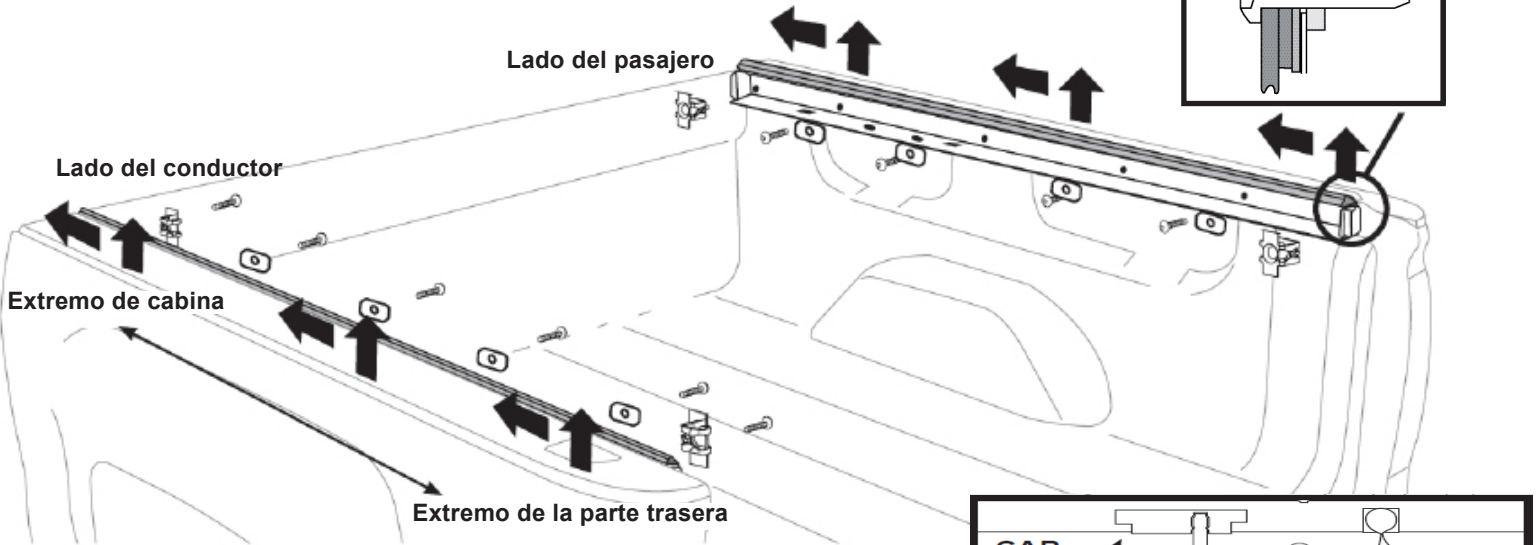

Quando coloque la cubierta, alinee el gancho de la abrazadera estacionaria a la posición más al frente de la ranura, más cercana a la cabina.

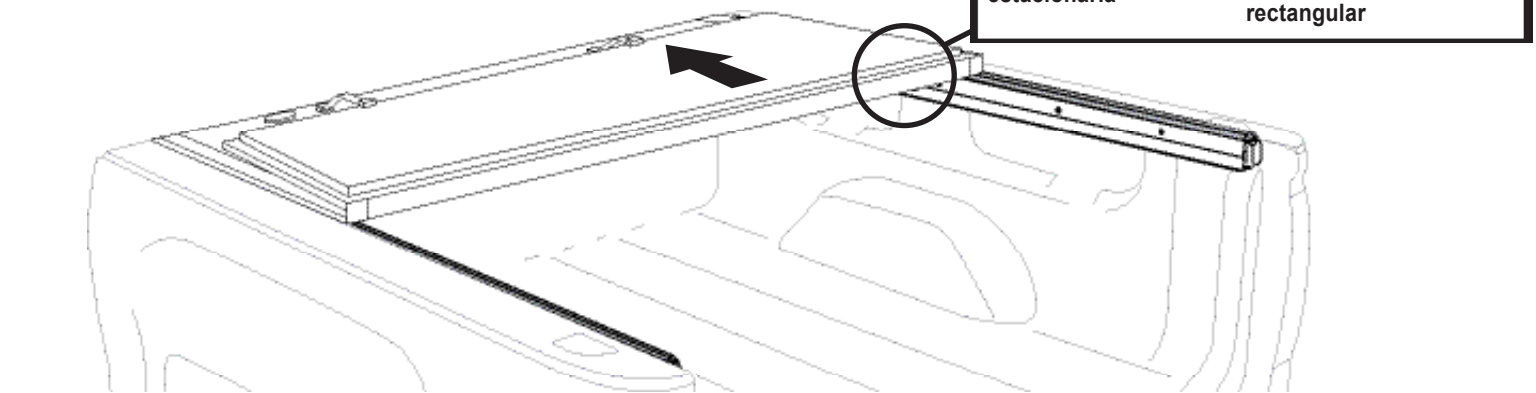

Active la puerta trasera por lo menos 5 veces +5X para asegurar la función adecuada.

