

Automatic Transmission Control Lever Knob Package Installation

1. Apply parking brake.

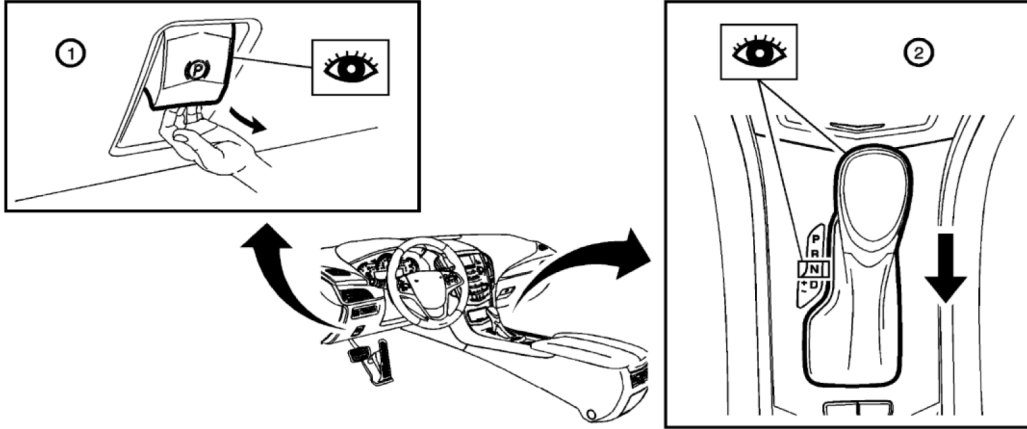

Cadillac ATS

2. Move shift knob to neutral.

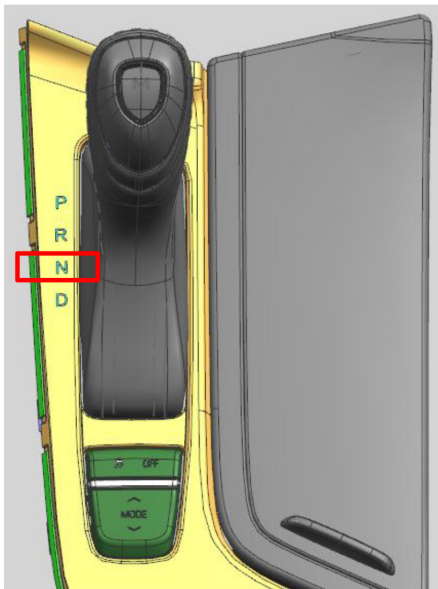

Cadillac CTS

3. Using trim tool, remove boot frame from console trimplate at 6 retainer tab locations.

4. Use caution not to damage 2-pin electrical wiring connection.

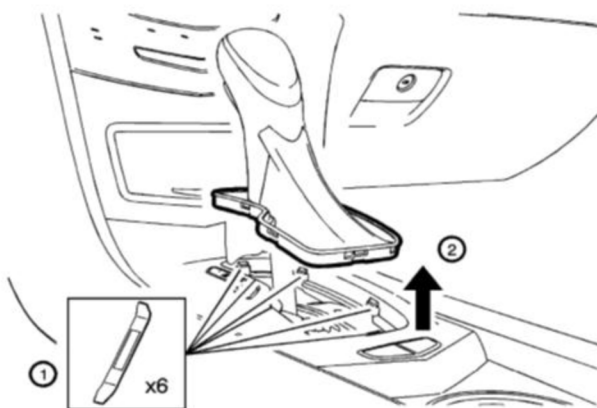

Cadillac ATS

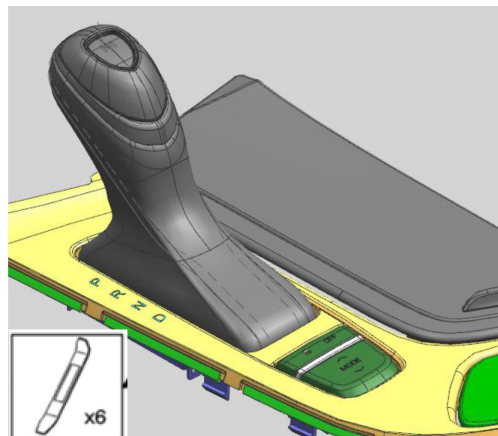

Cadillac CTS

Automatic Transmission Control Lever Knob Package

IR 16MY13

PART NO.

23201593

SHEET **1** OF **3**

ALL INFORMATION WITHIN ABOVE BORDER TO BE PRINTED EXACTLY AS SHOWN ON 8.5 x 11 WHITE 16 POUND NON-BOND RECYCLABLE PAPER. PRINT ON BOTH SIDES, EXCLUDING TEMPLATES. TO BE UNITIZED IN ACCORDANCE WITH GM SPECIFICATIONS.

DATE	REVISION	AUTH	DR
16MY13	Initial Release - Jeff D. Roland	1905224	

TITLE	PART NO.	SHEET	OF
INSTALLATION INSTRUCTIONS Automatic Transmission Control Lever Knob Package	23201593	1	3

5. Pull up on shift knob boot to access 2-pin electrical connection.
6. Remove electrical connector.

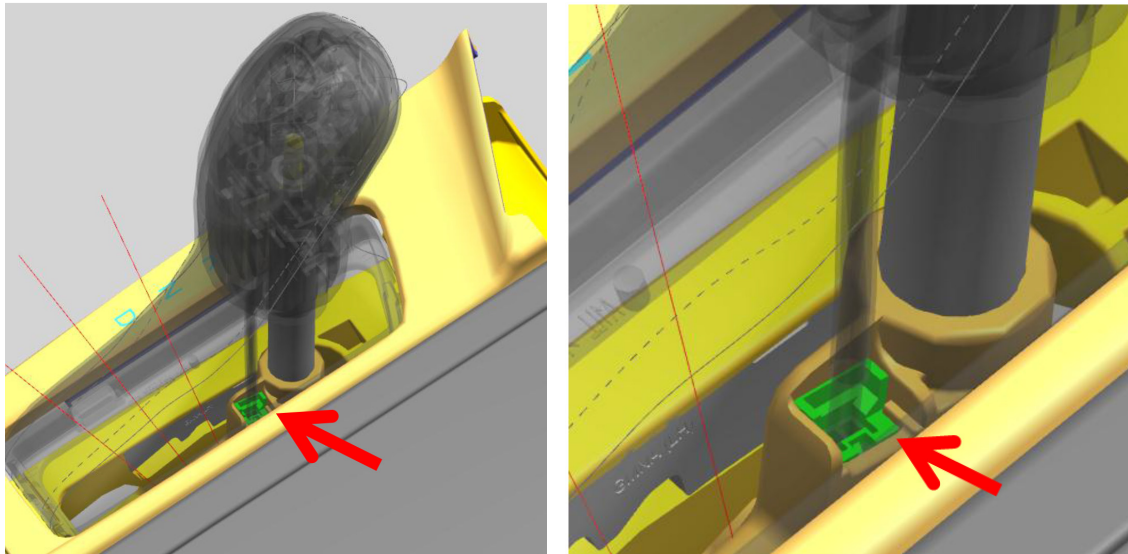

Cadillac CTS

7. Using twist and pull motion, grip shift knob with both hands to remove knob from shifter shaft.

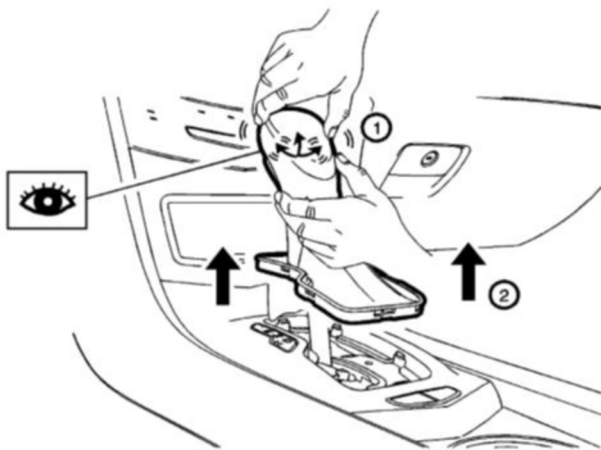

Cadillac ATS

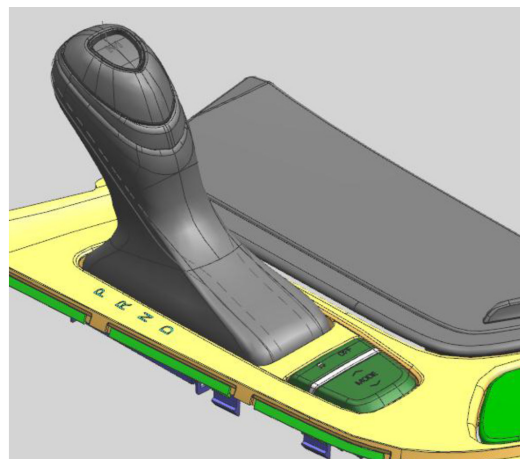

Cadillac CTS

Automatic Transmission Control Lever Knob Package

IR 16MY13

PART NO. **23201593**

SHEET **2** OF **3**

ALL INFORMATION WITHIN ABOVE BORDER TO BE PRINTED EXACTLY AS SHOWN ON 8.5 x 11 WHITE 16 POUND NON-BOND RECYCLABLE PAPER. PRINT ON BOTH SIDES, EXCLUDING TEMPLATES. TO BE UNITIZED IN ACCORDANCE WITH GM SPECIFICATIONS.

DATE	REVISION	AUTH	DR

TITLE	INSTALLATION INSTRUCTIONS		
Automatic Transmission Control Lever Knob Package			
PART NO.	23201593	SHEET	2 OF 3

8. Install knob to shifter shaft on control assembly.

Install : KNOB ASM - A/TRNS CONT LVR (W/ A/TRNS CONT OPG CVR)

to
CONTROL - A/TRNS (C)
and
PLATE - FRT FLR UPR CNSL TR (B)
with
6 INTEGRAL RETAINERS (A)
and
2 INTEGRAL LOCATORS (L)
and
INTEGRAL CONNECTOR (X)

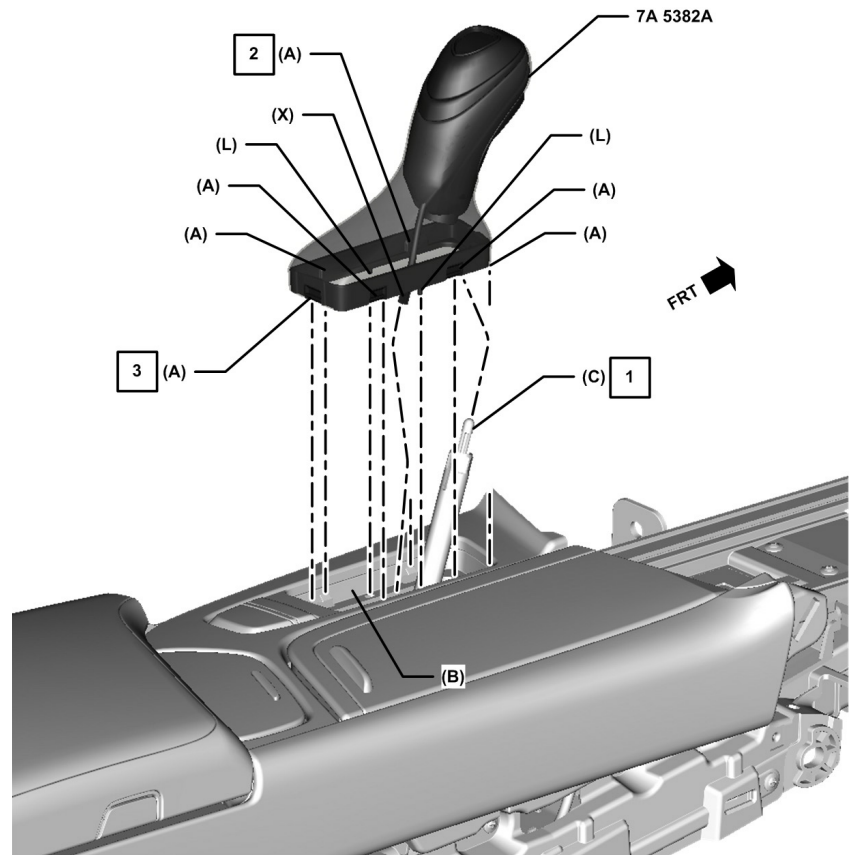

Cadillac CTS

INSTALLATION PROCEDURE:

1. Install knob to shifter shaft on control assembly.
2. Connect 2-pin electrical connection from knob to control assembly.
3. Install knob to shaft until retainer clip is engaged with audible snap.
4. Ensure knob is fully secured to shifter shaft. Pull up on knob to ensure knob is fully seated.
5. Install front end of boot to plate. Audible snap should be heard when installed.
6. Install rear end of boot to plate. Audible snap should be heard when installed.
7. After console is secure, move shifter to park position. Shifter must be in park position until cable adjuster is locked and secured.

ALL INFORMATION WITHIN ABOVE BORDER TO BE PRINTED EXACTLY AS SHOWN ON 8.5 x 11 WHITE 16 POUND NON-BOND RECYCLABLE PAPER. PRINT ON BOTH SIDES, EXCLUDING TEMPLATES. TO BE UNITIZED IN ACCORDANCE WITH GM SPECIFICATIONS.

DATE	REVISION	AUTH	DR