

Cargo Divider Panel Package

1. Cargo divider designed to retain cargo in a fixed position within the pick-up box. Can be positioned at any of the 3 upper tie down locations along the bed walls.

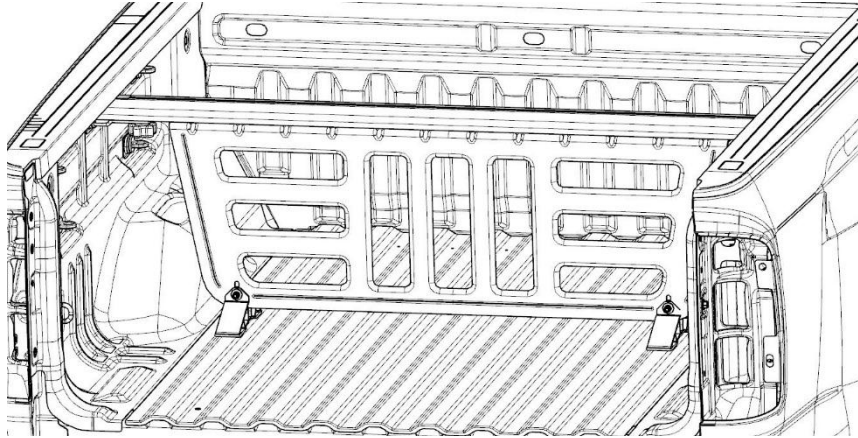

Tools required: Ratchet with 13mm socket
Screwdriver or ratchet extension

Steps 2-7 are for Cargo Divider Panel sub-assembly

2. The Cargo Divider Panel PKG is designed to be an add-on to the Tiered Storage Bar PKG.

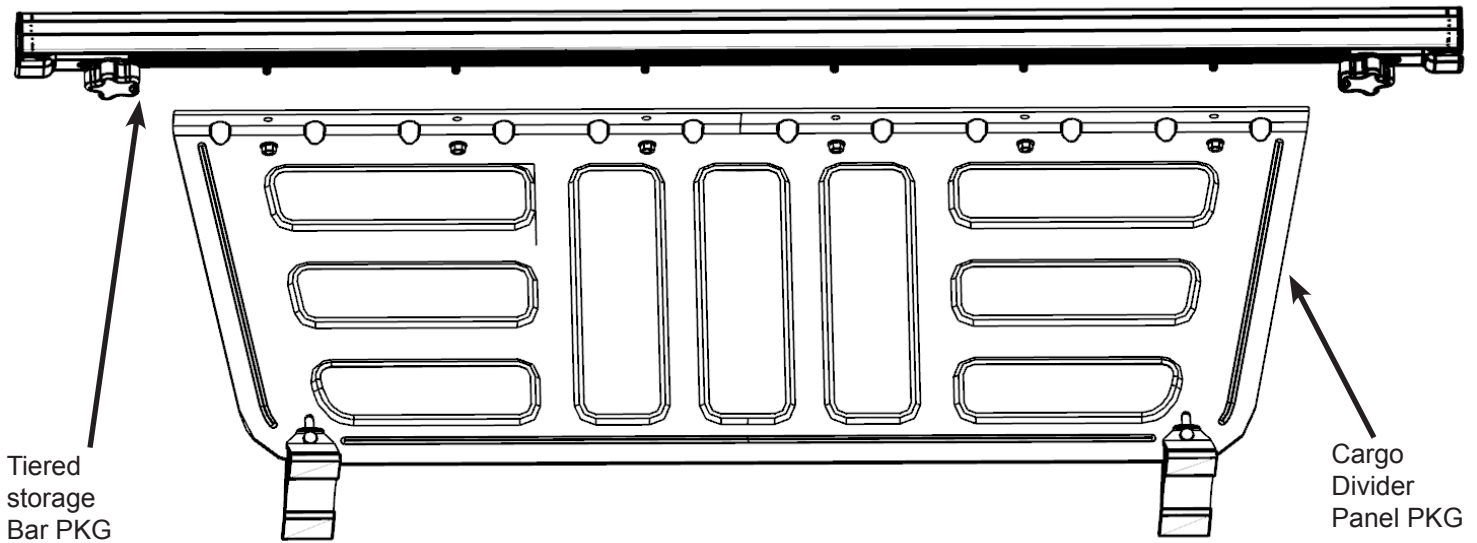

31XX Cargo Divider Panel Kit

IR 18NO14

PART NO.

23286043

SHEET

1 OF 15

ALL INFORMATION WITHIN ABOVE BORDER TO BE PRINTED EXACTLY AS SHOWN ON 8.5 x 11 WHITE 16 POUND NON-BOND RECYCLABLE PAPER. PRINT ON BOTH SIDES, EXCLUDING TEMPLATES. TO BE UNITIZED IN ACCORDANCE WITH GM SPECIFICATIONS.

DATE	REVISION	AUTH	DR
18NO14	Initial Release - Kyle Kakstis	2116376	

TITLE
INSTALLATION INSTRUCTIONS
31XX Cargo Divider Panel Kit
PART NO. 23286043
SHEET 1 OF 15

ACCESSORIES

- Slide stabilizer foot onto cargo divider panel at each corner, aligning the hole in the foot to the vertical slot in the panel. Insert M8 Hex Head Bolt through the hole, and loosely install the nut & washer on the opposing flat side of the stabilizer foot. Do not tighten.

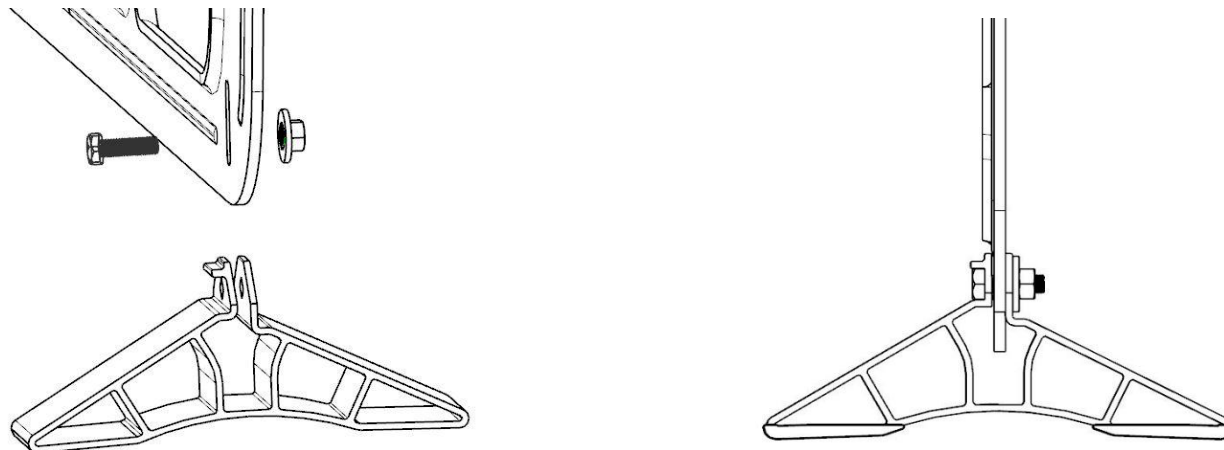

- Slide and remove latch assembly from each end of the Tiered Storage Bar PKG. Set aside for final assembly.

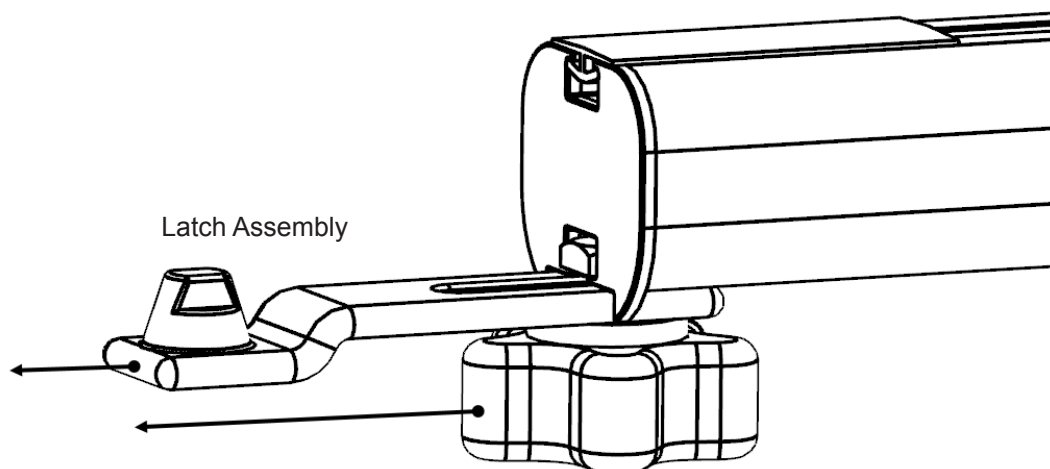

31XX Cargo Divider Panel Kit

IR 18NO14

PART NO. **23286043**

SHEET **2** OF **15**

ALL INFORMATION WITHIN ABOVE BORDER TO BE PRINTED EXACTLY AS SHOWN ON 8.5 x 11 WHITE 16 POUND NON-BOND RECYCLABLE PAPER. PRINT ON BOTH SIDES, EXCLUDING TEMPLATES. TO BE UNITIZED IN ACCORDANCE WITH GM SPECIFICATIONS.

DATE	REVISION	AUTH	DR
18NO14	Initial Release - Kyle Kakstis	2116376	

TITLE	INSTALLATION INSTRUCTIONS 31XX Cargo Divider Panel Kit		
PART NO.	23286043	SHEET	2 OF 15

- Slide the 6 M8 square head bolts into the lower channel of the Tiered Storage Bar. Align the fasteners with the holes in the top of the Cargo Divider Panel, and join the components together.

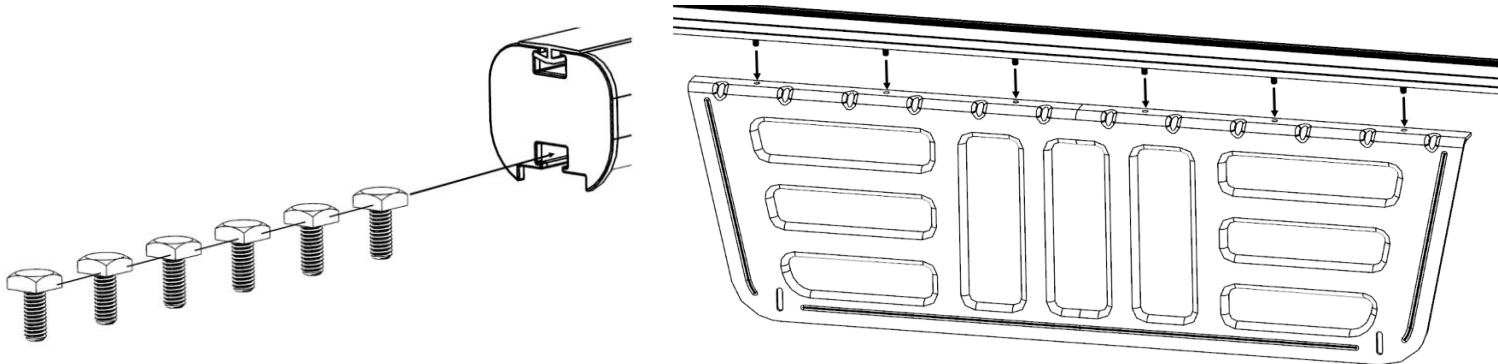

- Loosely install the 6 M8 nuts onto the M8 square head bolt threads. Use a measuring tape to center the panel onto the Tiered Storage Bar. Torque the nuts to 22Nm.

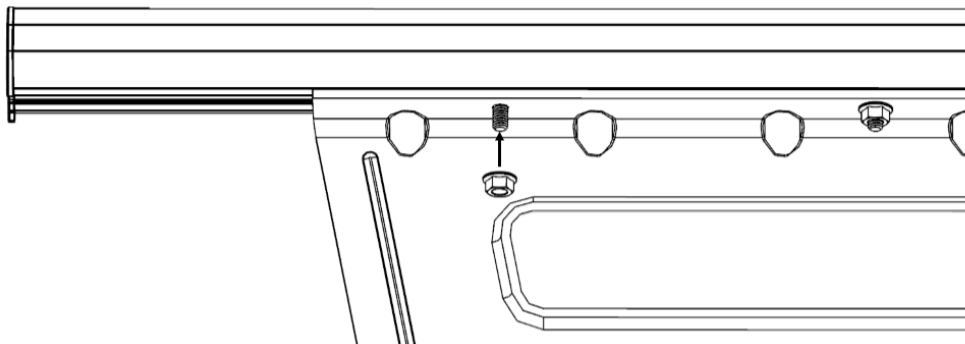

- Slide loose latch assembly back into each end of the Tiered Storage Bar lower channel. The knob should be closest to the Cargo Divider panel on each end. Cargo Divider sub-assembly complete.

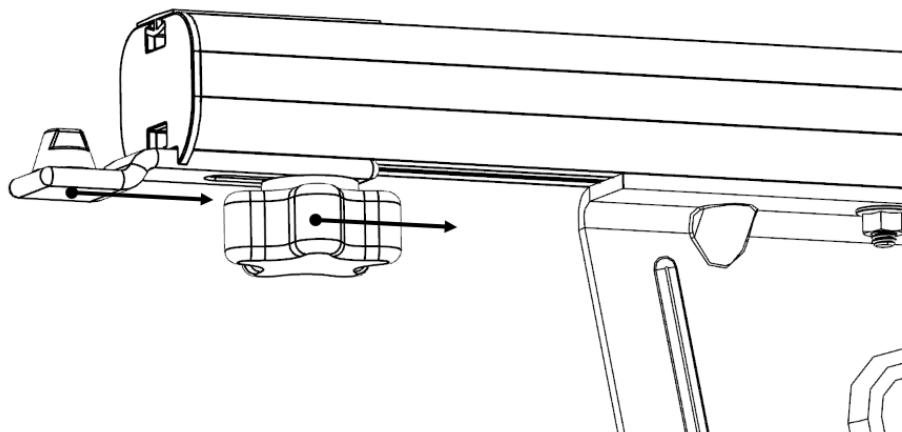

31XX Cargo Divider Panel Kit

IR 18NO14

PART NO.

23286043

SHEET

3 OF 15

ALL INFORMATION WITHIN ABOVE BORDER TO BE PRINTED EXACTLY AS SHOWN ON 8.5 x 11 WHITE 16 POUND NON-BOND RECYCLABLE PAPER. PRINT ON BOTH SIDES, EXCLUDING TEMPLATES. TO BE UNITIZED IN ACCORDANCE WITH GM SPECIFICATIONS.

DATE	REVISION	AUTH	DR
18NO14	Initial Release - Kyle Kakstis	2116376	

TITLE	INSTALLATION INSTRUCTIONS		
	31XX Cargo Divider Panel Kit		
PART NO.	23286043	SHEET	3 OF 15

Steps 8-12 are for assembly to vehicle

- Prior to assembly, ensure tie downs are tightened and oriented horizontally. After hand-tightening the tie down, insert a hand tool such as a screw driver or ratchet extension through the loop and use to tighten 1 to 2 half turns further.

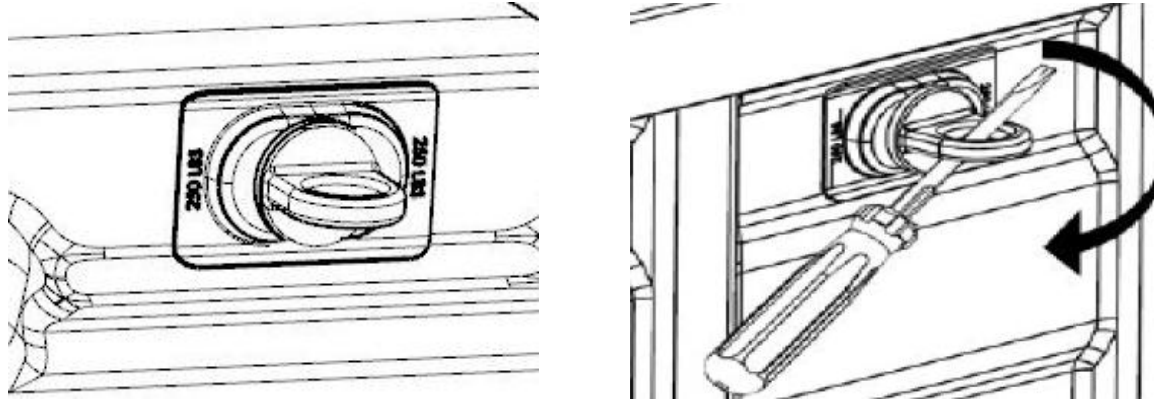

- With the end caps pointed down and the protectant strip facing up, place the cargo divider on top of each of the opposing tie down loops.

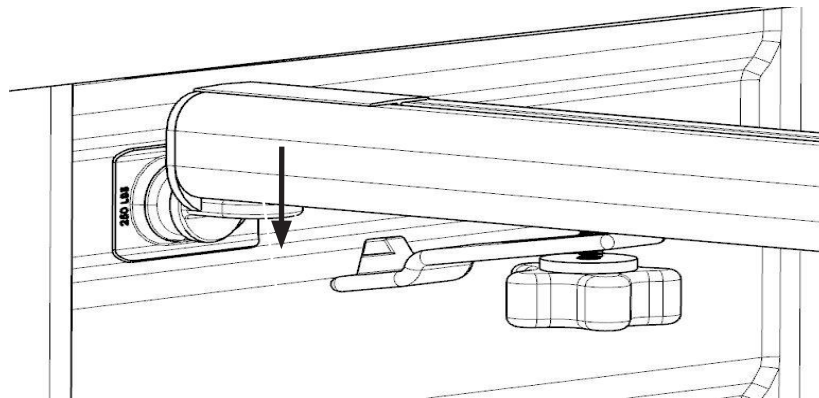

- With cargo divider resting on top of the tie downs, push stabilizer foot down so that both legs rest flat against the pick-up bed floor. Tighten the nut while maintaining downward pressure on the stabilizer foot. Repeat for adjacent stabilizer foot.

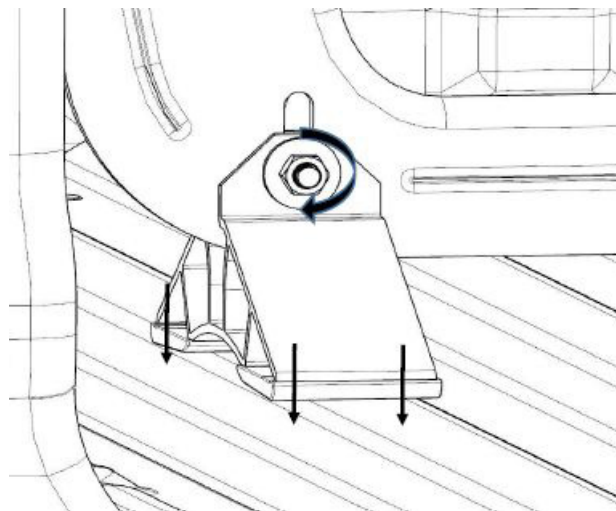

31XX Cargo Divider Panel Kit

IR 18NO14

PART NO.

23286043

SHEET

4 OF 15

ALL INFORMATION WITHIN ABOVE BORDER TO BE PRINTED EXACTLY AS SHOWN ON 8.5 x 11 WHITE 16 POUND NON-BOND RECYCLABLE PAPER. PRINT ON BOTH SIDES, EXCLUDING TEMPLATES. TO BE UNITIZED IN ACCORDANCE WITH GM SPECIFICATIONS.

DATE	REVISION	AUTH	DR
18NO14	Initial Release - Kyle Kakstis	2116376	

TITLE		INSTALLATION INSTRUCTIONS	
		31XX Cargo Divider Panel Kit	
PART NO.	23286043	SHEET	4 OF 15

11. Slide each loose latch assembly toward the tie down loops and ensure the cylinder is inserted through the tie down loop.

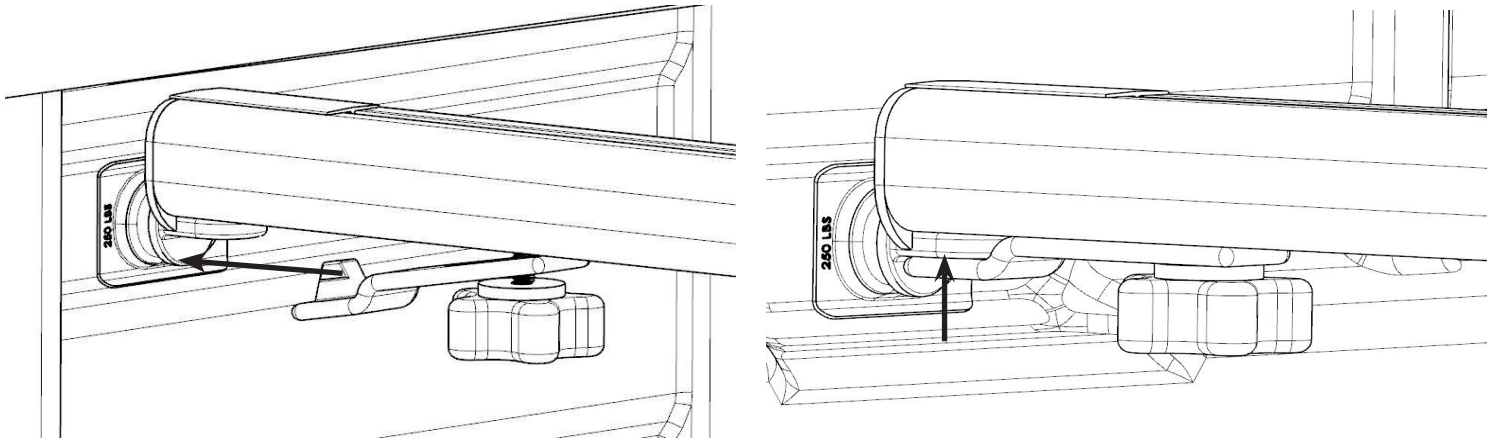

12. Hand-tighten the knobs as close to the tie downs as possible for maximum retention. Verify that both sides are fastened. Assembly is complete.

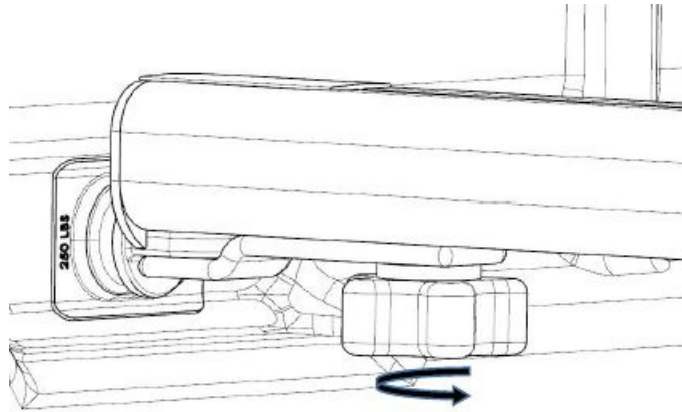

31XX Cargo Divider Panel Kit

IR 18NO14

PART NO.

23286043

SHEET

5 OF **15**

ALL INFORMATION WITHIN ABOVE BORDER TO BE PRINTED EXACTLY AS SHOWN ON 8.5 x 11 WHITE 16 POUND NON-BOND RECYCLABLE PAPER. PRINT ON BOTH SIDES, EXCLUDING TEMPLATES. TO BE UNITIZED IN ACCORDANCE WITH GM SPECIFICATIONS.

DATE	REVISION	AUTH	DR
18NO14	Initial Release - Kyle Kakstis	2116376	

TITLE	INSTALLATION INSTRUCTIONS		
	31XX Cargo Divider Panel Kit		
PART NO.	23286043	SHEET	5 OF 15

Groupe panneau séparateur de chargement

1. Le séparateur d'espace de chargement est conçu pour assujettir le chargement à l'intérieur de la caisse de la camionnette. Le séparateur peut être placé à n'importe quel des trois points d'attache supérieurs le long des parois de la caisse.

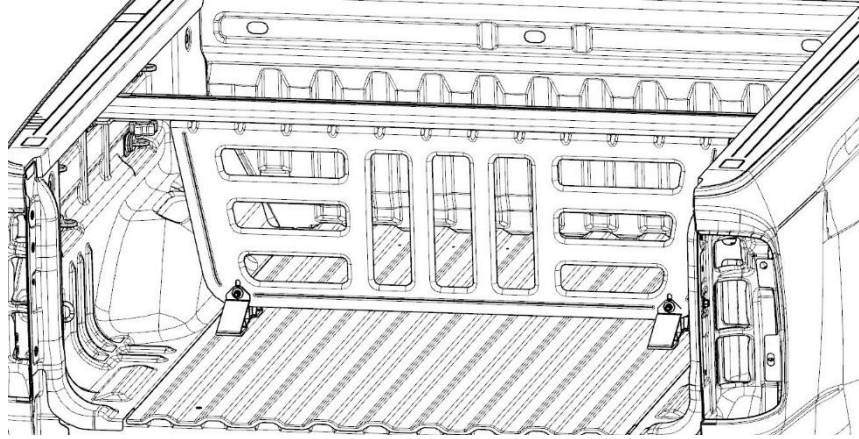

Outil requis : clé à cliquet avec douille 13 mm
 Tournevis ou rallonge de clé à cliquet

Les étapes 2 à 7 concernent le sous-ensemble du panneau séparateur de chargement.

2. Le groupe de panneau séparateur de chargement est conçu comme un ajout au groupe de barre de rangement étagé.

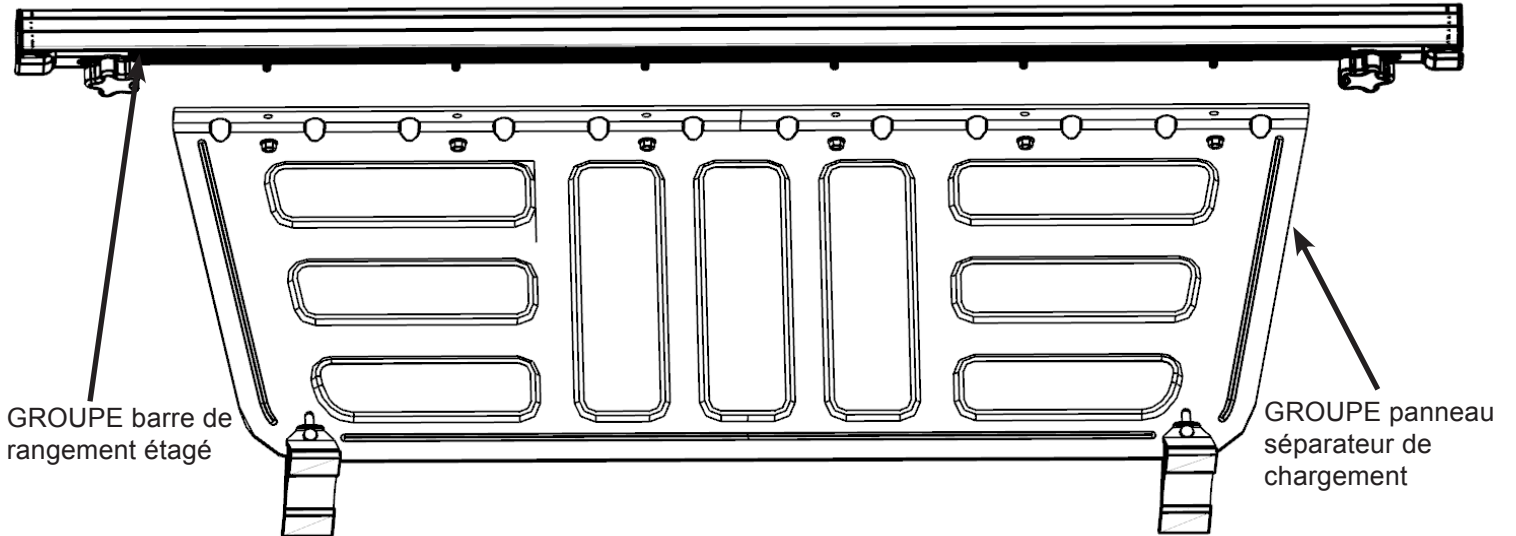

31XX Cargo Divider Panel Kit

IR 18NO14

PART NO. **23286043**

SHEET **6** OF **15**

ALL INFORMATION WITHIN ABOVE BORDER TO BE PRINTED EXACTLY AS SHOWN ON 8.5 x 11 WHITE 16 POUND NON-BOND RECYCLABLE PAPER. PRINT ON BOTH SIDES, EXCLUDING TEMPLATES. TO BE UNITIZED IN ACCORDANCE WITH GM SPECIFICATIONS.

DATE	REVISION	AUTH	DR
18NO14	Initial Release - Kyle Kakstis	2116376	

INSTALLATION INSTRUCTIONS	
31XX Cargo Divider Panel Kit	
PART NO.	23286043
SHEET	6 OF 15

3. Glisser un pied stabilisateur à chaque coin du panneau séparateur d'espace de chargement, puis aligner le trou du pied dans la fente verticale du panneau. Insérer un boulon à tête hexagonale M8 dans le trou, puis poser sans les serrer l'écrou et la rondelle sur le côté plat opposé du pied stabilisateur. Ne pas serrer.

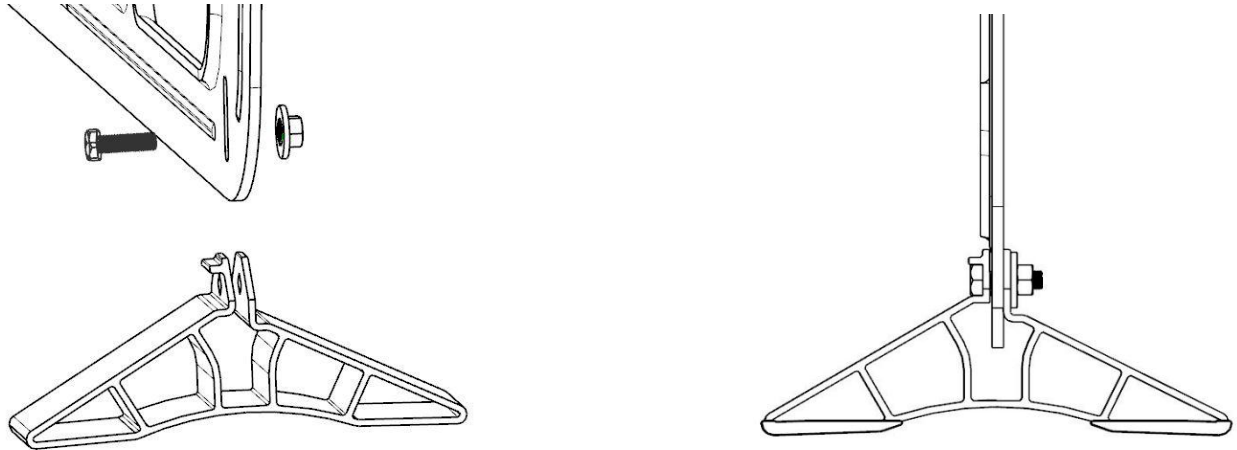

4. Glisser et retirer l'ensemble loquet de chaque extrémité de la barre de rangement étagé. Les mettre de côté pour l'assemblage final.

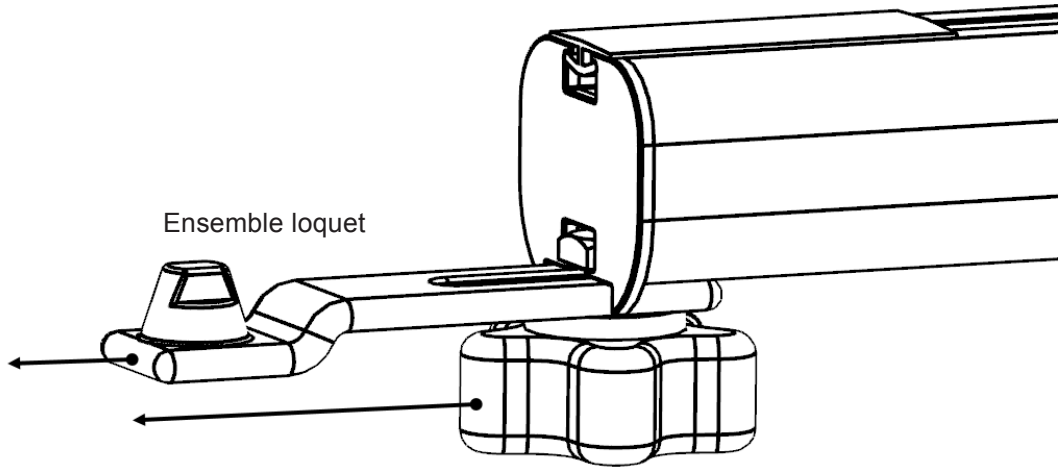

31XX Cargo Divider Panel Kit

IR 18NO14

PART NO. **23286043**

SHEET **7** OF **15**

ALL INFORMATION WITHIN ABOVE BORDER TO BE PRINTED EXACTLY AS SHOWN ON 8.5 x 11 WHITE 16 POUND NON-BOND RECYCLABLE PAPER. PRINT ON BOTH SIDES, EXCLUDING TEMPLATES. TO BE UNITIZED IN ACCORDANCE WITH GM SPECIFICATIONS.

DATE	REVISION	AUTH	DR
18NO14	Initial Release - Kyle Kakstis	2116376	

TITLE	INSTALLATION INSTRUCTIONS 31XX Cargo Divider Panel Kit		
PART NO.	23286043	SHEET	7 OF 15

5. Glisser les 6 boulons à tête carrée M8 dans les rainures inférieures de la barre de rangement étagé. Aligner les fixations avec les trous sur le dessus du panneau séparateur de chargement et assembler les composants ensemble.

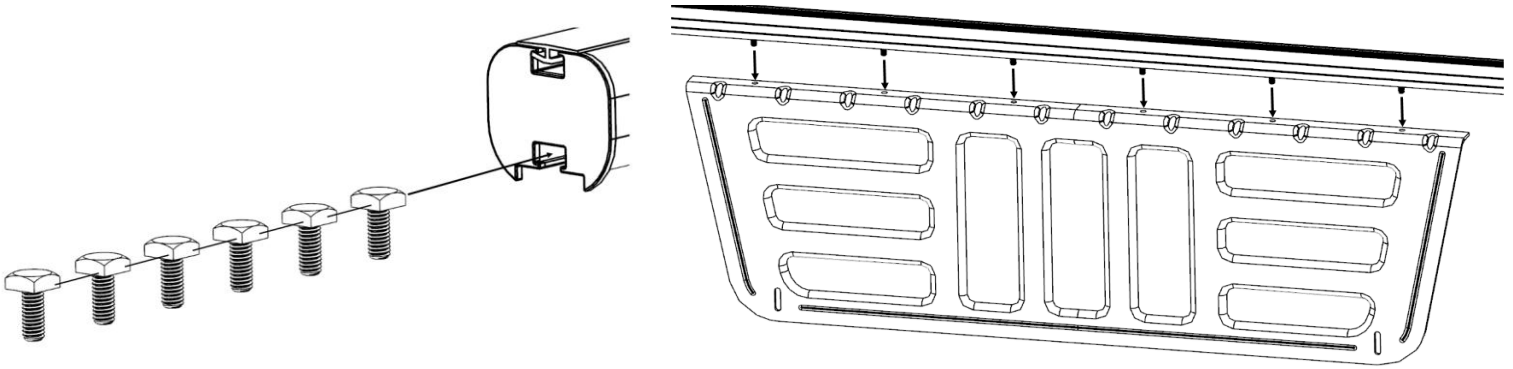

6. Poser sans les serrer les 6 écrous M8 sur les filets de boulon à tête carrée M8. Utiliser un ruban à mesurer pour centrer le panneau sur la barre de rangement étagé. Serrer les écrous à 22 Nm.

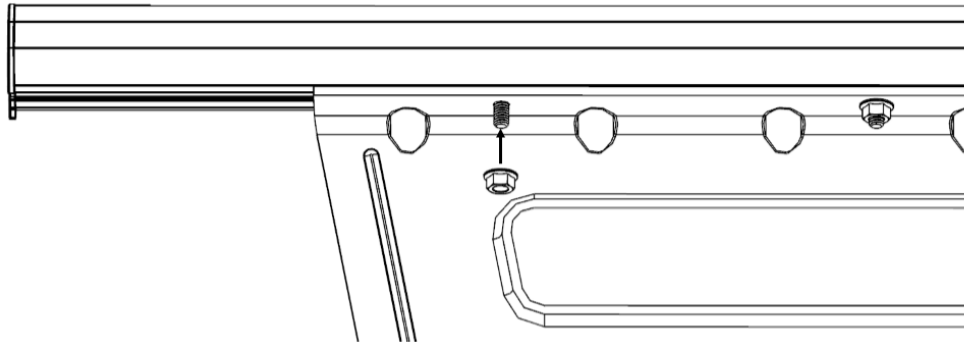

7. Glisser l'ensemble loquet dans la rainure inférieure à chaque extrémité de la barre de rangement étagé. La molette doit être aussi près que possible du panneau séparateur de chargement à chaque extrémité.

Sous-ensemble séparateur de chargement terminé.

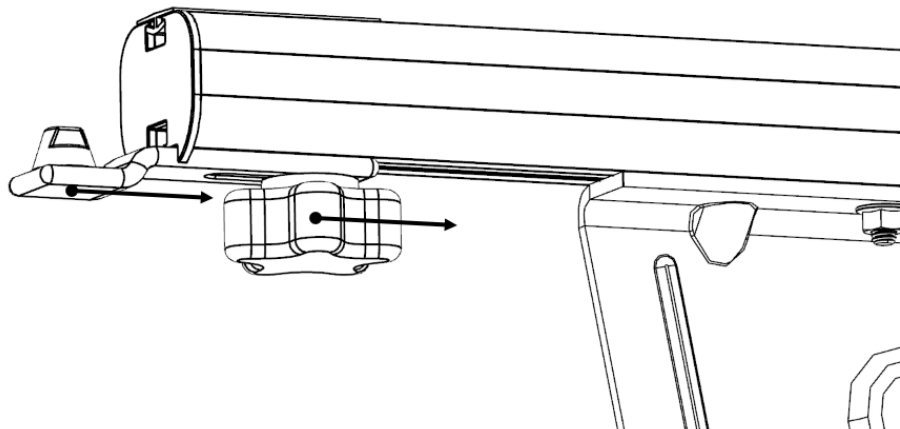

31XX Cargo Divider Panel Kit

IR 18NO14

PART NO. 23286043

SHEET 8 OF 15

ALL INFORMATION WITHIN ABOVE BORDER TO BE PRINTED EXACTLY AS SHOWN ON 8.5 x 11 WHITE 16 POUND NON-BOND RECYCLABLE PAPER. PRINT ON BOTH SIDES, EXCLUDING TEMPLATES. TO BE UNITIZED IN ACCORDANCE WITH GM SPECIFICATIONS.

DATE	REVISION	AUTH	DR
18NO14	Initial Release - Kyle Kakstis	2116376	

INSTALLATION INSTRUCTIONS	
31XX Cargo Divider Panel Kit	
PART NO.	23286043
SHEET	8 OF 15

Les étapes 8 à 12 concernent l'assemblage sur le véhicule.

- Avant l'assemblage, s'assurer que les points d'attache sont serrés et orientés à l'horizontale. Après le serrage à main de l'arrimage, insérer un outil à main, comme un tournevis ou une rallonge de cliquet à travers la boucle et utiliser pour serrer de 1 à 2 demi-tours de plus.

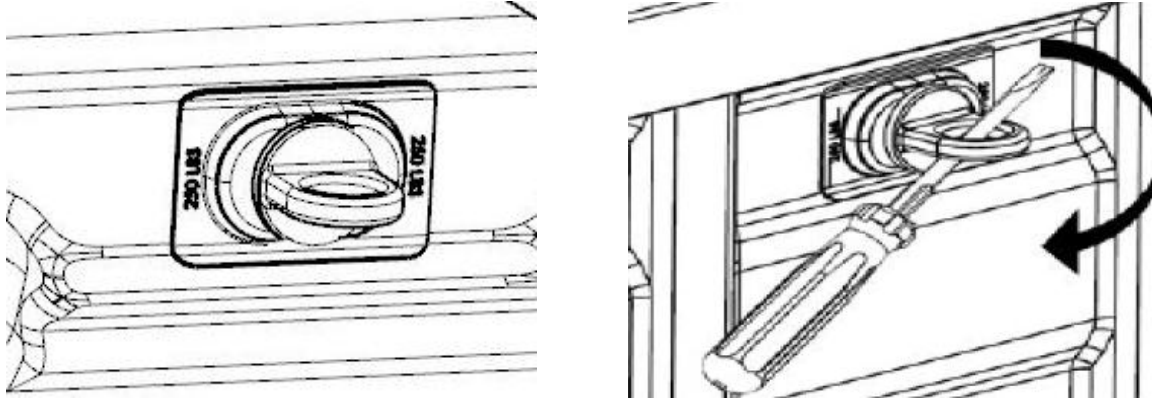

- Orienter les embouts vers le bas et la bande de protections vers le haut, puis placer le séparateur d'espace de chargement sur le dessus de chacun des anneaux d'attache opposés.

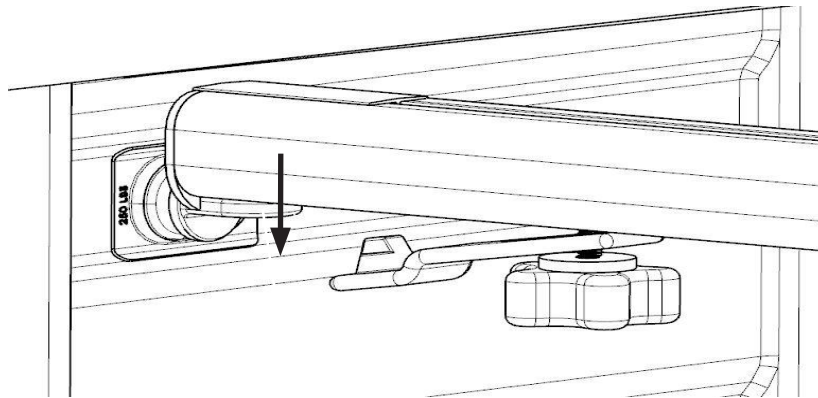

- Lorsque le séparateur d'espace de chargement repose sur le dessus des points d'attache, pousser le pied stabilisateur vers le bas afin que les deux pattes reposent à plat contre le fond de la caisse de la camionnette. Serrer l'écrou en continuant d'appliquer une pression vers le bas sur le pied stabilisateur. Répéter la procédure pour le pied stabilisateur adjacent.

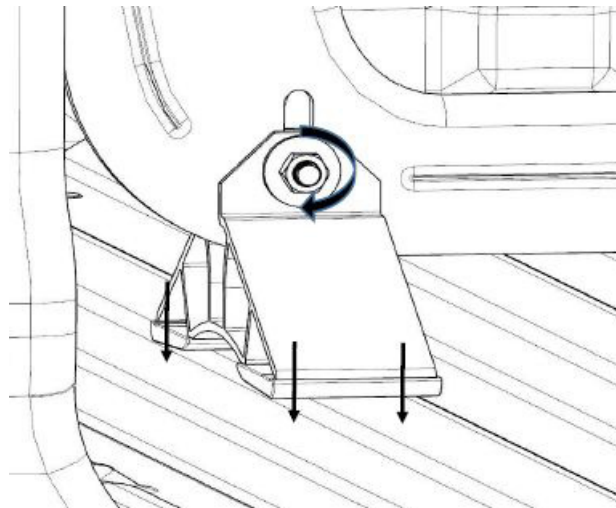

31XX Cargo Divider Panel Kit

IR 18NO14

PART NO.

23286043

SHEET

9 OF 15

ALL INFORMATION WITHIN ABOVE BORDER TO BE PRINTED EXACTLY AS SHOWN ON 8.5 x 11 WHITE 16 POUND NON-BOND RECYCLABLE PAPER. PRINT ON BOTH SIDES, EXCLUDING TEMPLATES. TO BE UNITIZED IN ACCORDANCE WITH GM SPECIFICATIONS.

DATE	REVISION	AUTH	DR
18NO14	Initial Release - Kyle Kakstis	2116376	

TITLE	INSTALLATION INSTRUCTIONS		
	31XX Cargo Divider Panel Kit		
PART NO.	23286043	SHEET	9 OF 15

11. Glisser chaque ensemble loquet mobile vers les anneaux d'attache et s'assurer que le cylindre est inséré dans l'anneau d'attache.

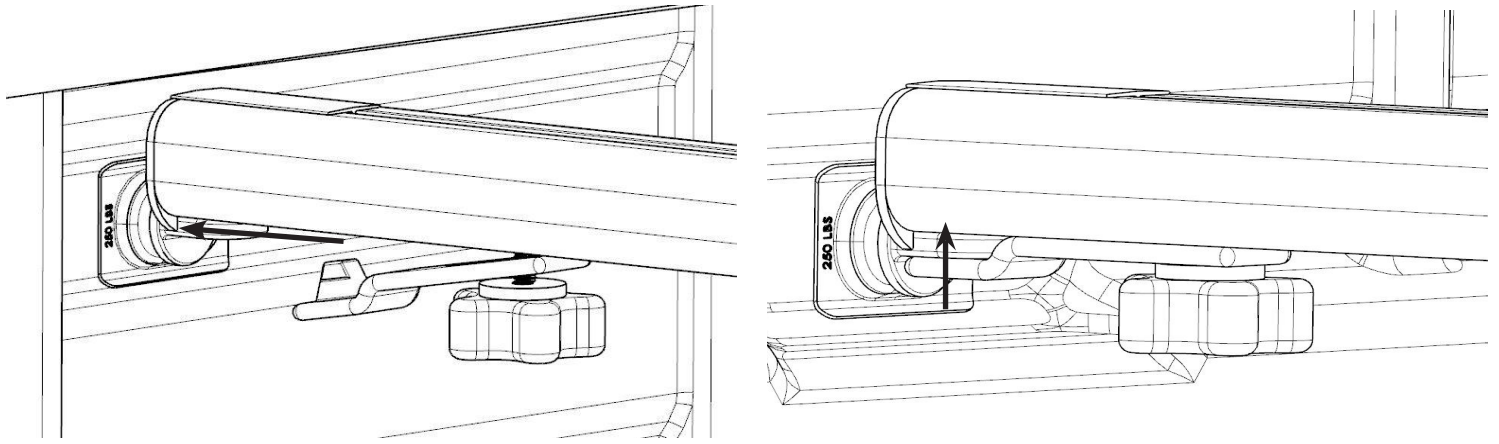

12. Serrer à la main les boulons étoiles aussi près que possible des points d'attache pour assurer une solidité maximale. Vérifier que les deux côtés sont bien fixés. L'assemblage est terminé.

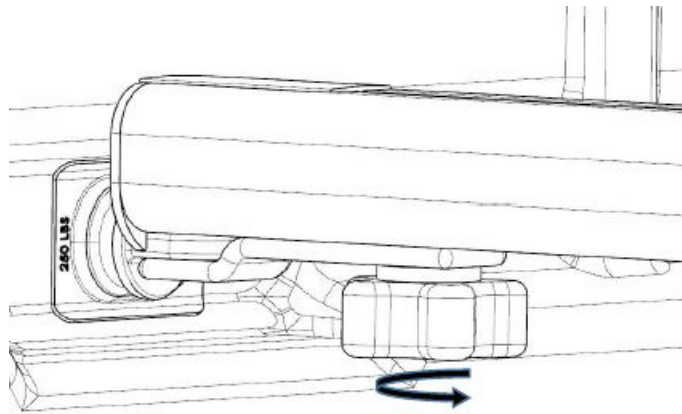

31XX Cargo Divider Panel Kit

IR 18NO14

PART NO. **23286043**

SHEET **10** OF **15**

ALL INFORMATION WITHIN ABOVE BORDER TO BE PRINTED EXACTLY AS SHOWN ON 8.5 x 11 WHITE 16 POUND NON-BOND RECYCLABLE PAPER. PRINT ON BOTH SIDES, EXCLUDING TEMPLATES. TO BE UNITIZED IN ACCORDANCE WITH GM SPECIFICATIONS.

DATE	REVISION	AUTH	DR
18NO14	Initial Release - Kyle Kakstis	2116376	

TITLE	INSTALLATION INSTRUCTIONS 31XX Cargo Divider Panel Kit		
PART NO.	23286043	SHEET	10 OF 15

Paquete de tablero de divisor de carga

1. Divisor de carga diseñado para retener carga en una posición fija dentro de la caja pick-up. Se puede colocar en cualquiera de las 3 ubicaciones de amarre superior a lo largo de la pared de la plataforma.

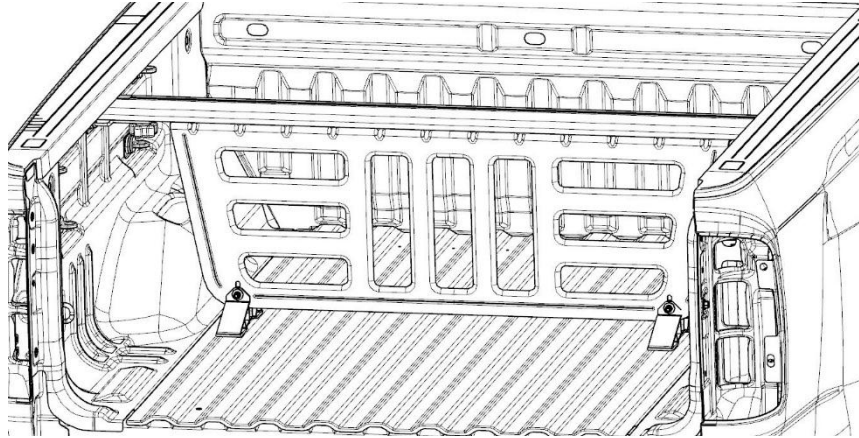

Herramientas requeridas: Matraca con casquillo de 13mm
Destornillador o extensión de matraca

Los pasos 2-7 son para el sub-ensamble del tablero divisor de carga

2. El paquete de tablero de divisor de carga está diseñado para ser una adición al Paquete de barra de almacenamiento en niveles.

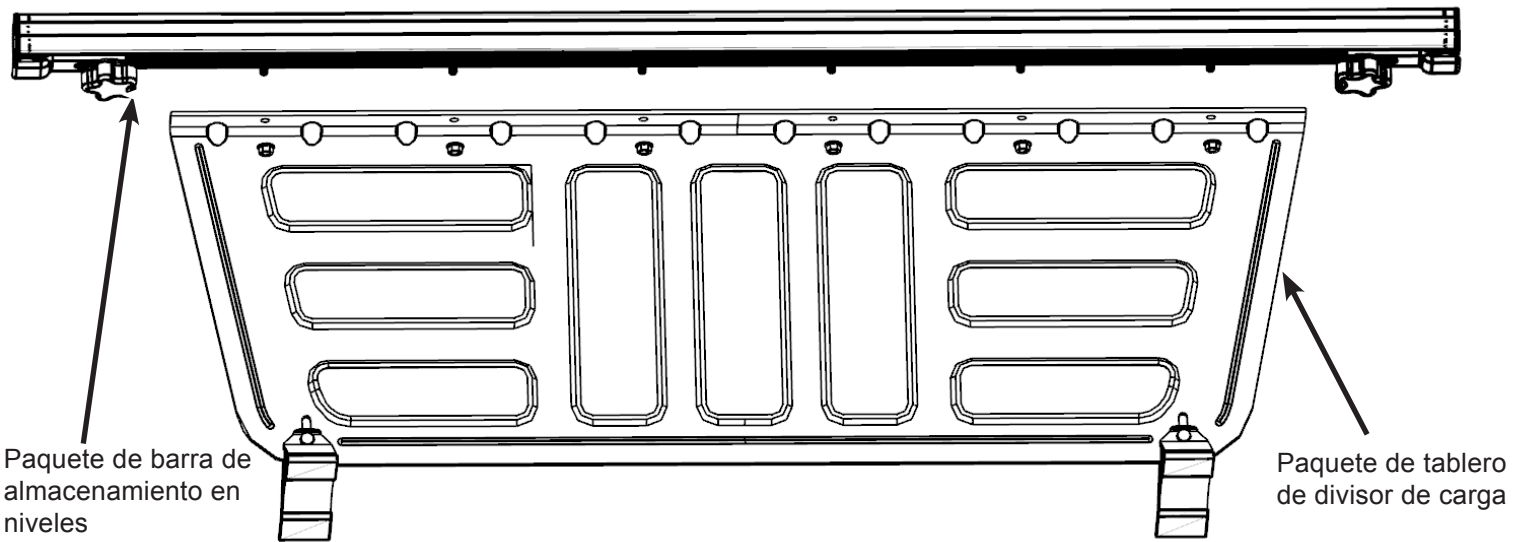

31XX Cargo Divider Panel Kit

IR 18NO14

PART NO. **23286043**

SHEET **11** OF **15**

ALL INFORMATION WITHIN ABOVE BORDER TO BE PRINTED EXACTLY AS SHOWN ON 8.5 x 11 WHITE 16 POUND NON-BOND RECYCLABLE PAPER. PRINT ON BOTH SIDES, EXCLUDING TEMPLATES. TO BE UNITIZED IN ACCORDANCE WITH GM SPECIFICATIONS.

DATE	REVISION	AUTH	DR
18NO14	Initial Release - Kyle Kakstis	2116376	

TITLE
INSTALLATION INSTRUCTIONS 31XX Cargo Divider Panel Kit
PART NO. 23286043 SHEET 11 OF 15

3. Deslice la pata estabilizadora sobre el tablero del divisor de carga en cada esquina, alineando el orificio en la pata a la ranura vertical en el tablero. Inserte el perno de cabeza hexagonal M8 a través del orificio, e instale holgadamente la tuerca y la arandela en el lado plano opuesto de la pata estabilizadora. No apriete.

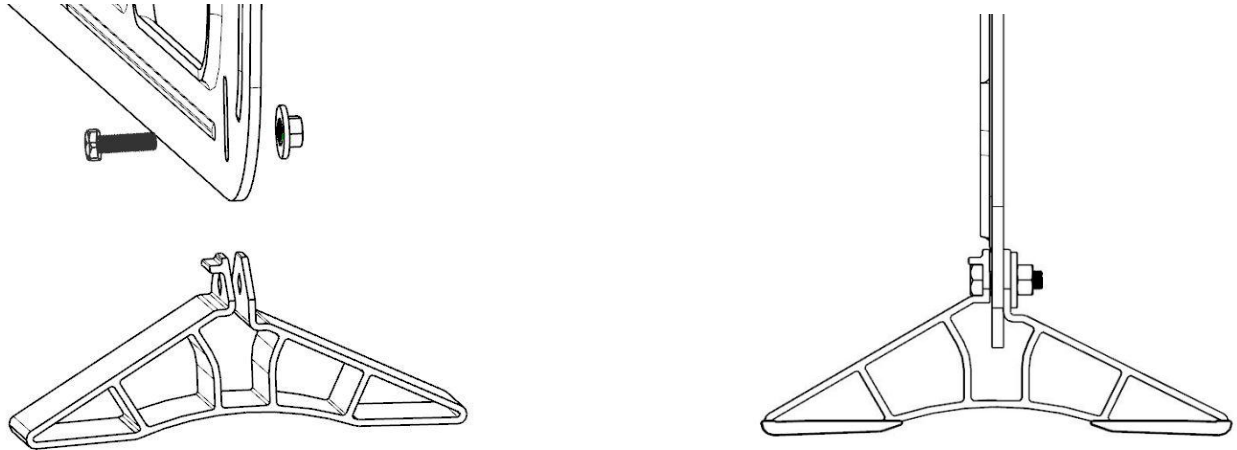

4. Deslice y retire el ensamble del seguro desde cada extremo del paquete de barra de almacenamiento en niveles para el ensamble final.

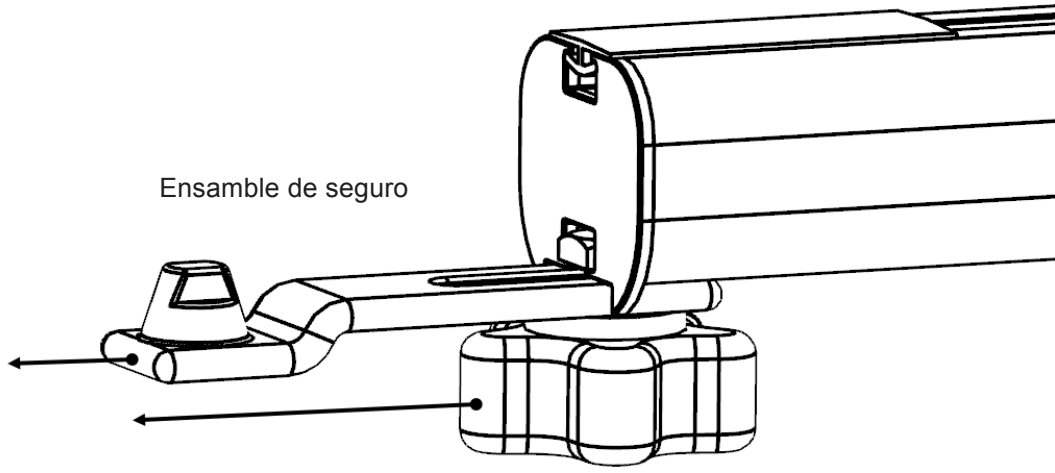

31XX Cargo Divider Panel Kit

IR 18NO14

PART NO. 23286043

SHEET 12 OF 15

ALL INFORMATION WITHIN ABOVE BORDER TO BE PRINTED EXACTLY AS SHOWN ON 8.5 x 11 WHITE 16 POUND NON-BOND RECYCLABLE PAPER. PRINT ON BOTH SIDES, EXCLUDING TEMPLATES. TO BE UNITIZED IN ACCORDANCE WITH GM SPECIFICATIONS.

DATE	REVISION	AUTH	DR
18NO14	Initial Release - Kyle Kakstis	2116376	

TITLE		INSTALLATION INSTRUCTIONS	
		31XX Cargo Divider Panel Kit	
PART NO.		23286043	
		SHEET 12 OF 15	

5. Deslice los 6 pernos de cabeza cuadrada M8 en el canal inferior de la barra de almacenamiento en niveles. Alinee lo sujetadores con los orificios en la parte superior del tablero de divisor de carga, y una los componentes.

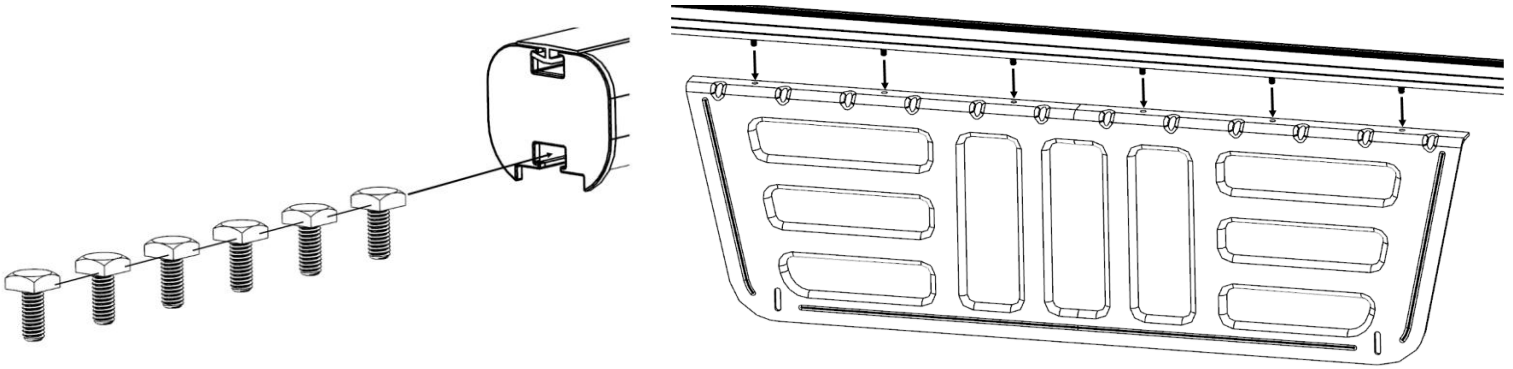

6. Instale holgadamente las 6 tuercas M8 sobre las roscas del perno de cabeza cuadrada M8. Use una cinta de medición para centrar el tablero sobre la barra de almacenamiento en niveles. Apriete las tuercas a 22Nm.

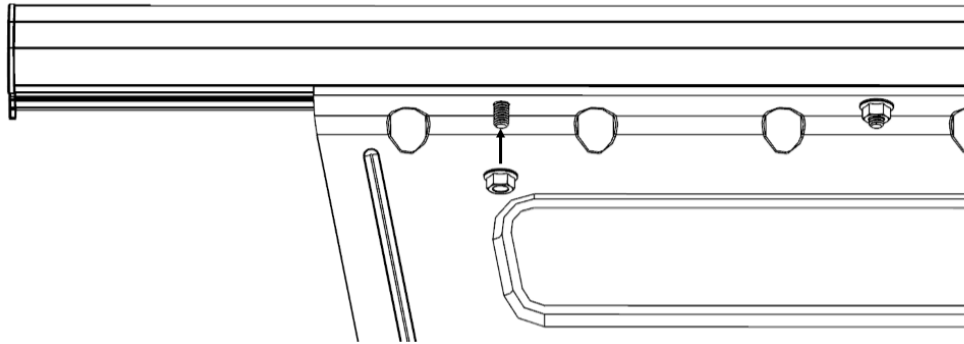

7. Deslice el ensamble de seguro suelto en cada extremo del canal inferior de la Barra de almacenamiento en niveles. La perilla debe estar más cerca al tablero del Divisor de carga en cada extremo.

Sub-ensamble de divisor de carga completo.

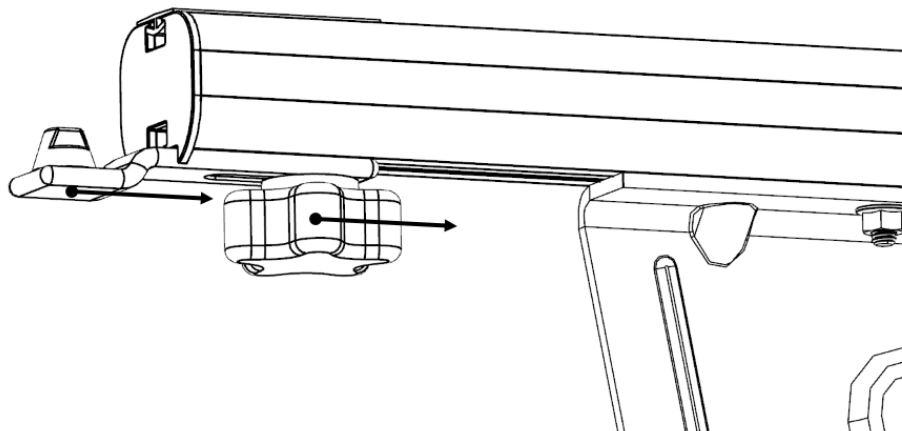

DATE	REVISION	AUTH	DR
18NO14	Initial Release - Kyle Kakstis	2116376	

TITLE	INSTALLATION INSTRUCTIONS		
31XX Cargo Divider Panel Kit			
PART NO.	23286043	SHEET	13 OF 15

Los pasos 8-12 son para ensamble al vehículo

8. Antes del ensamble, asegúrese que los amarres estén apretados y orientados horizontalmente. Después de apretar a mano el amarre, inserte una herramienta manual tal como un destornillador o extensión de matraca a través del circuito y úsela para apretar de 1 a 2 medias vueltas adicionales.

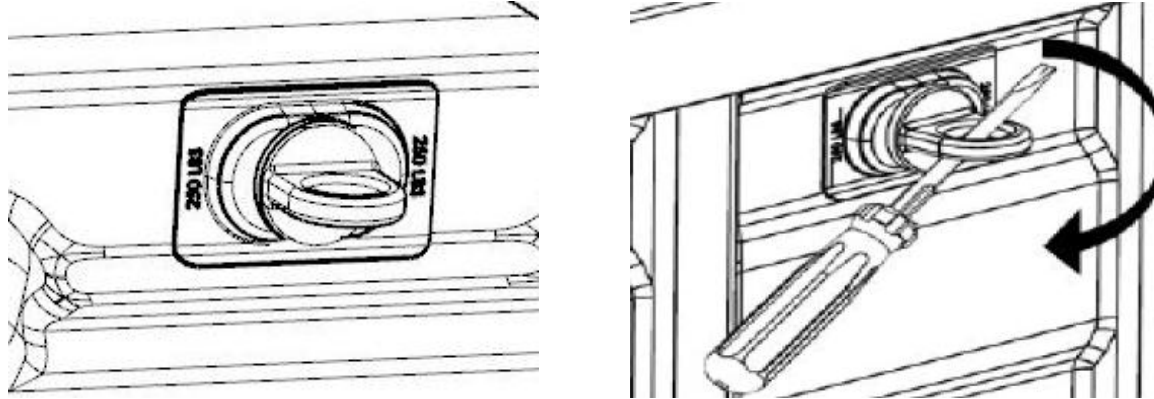

9. Con las tapas de extremo apuntadas hacia abajo y la cinta de protección viendo hacia arriba, coloque el divisor de carga sobre cada uno de los aros de amarre puestos.

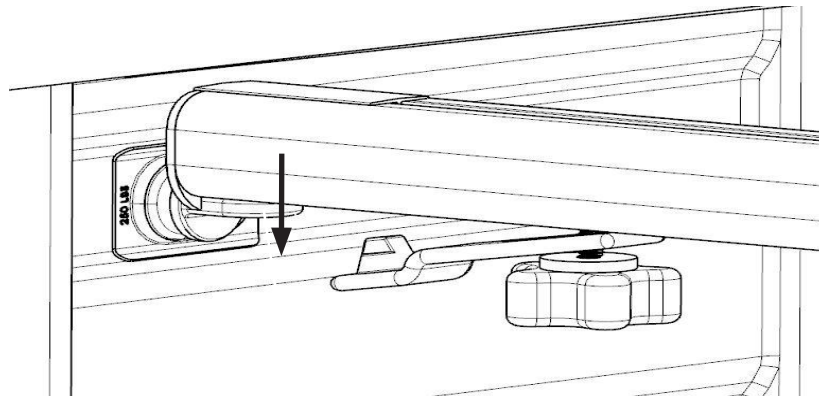

10. Con el divisor de carga descansando sobre la parte superior de los amarres, empuje la pata estabilizadora de forma que ambas patas descansen planas contra el piso de la plataforma pick-up. Apriete la tuerca mientras mantiene presión descendente sobre la pata estabilizadora. Repita para la pata estabilizadora adyacente.

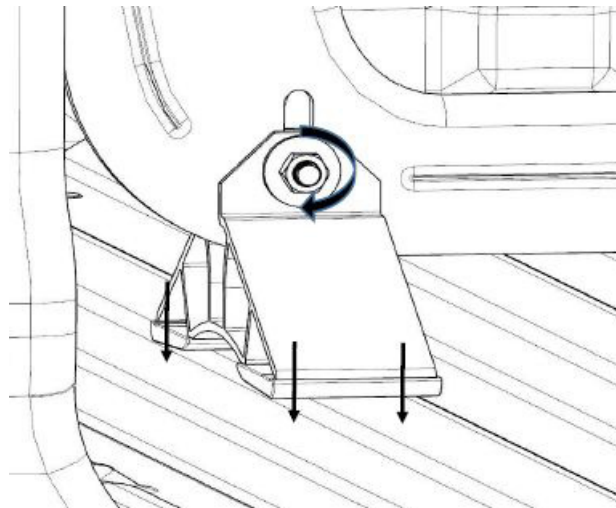

DATE	REVISION	AUTH	DR
18NO14	Initial Release - Kyle Kakstis	2116376	

TITLE	INSTALLATION INSTRUCTIONS		
	31XX Cargo Divider Panel Kit		
PART NO.	23286043	SHEET	14 OF 15

11. Deslice cada ensamble de seguro suelto hacia los aros de amarre y asegúrese que el cilindro esté insertado a través del aro de amarre.

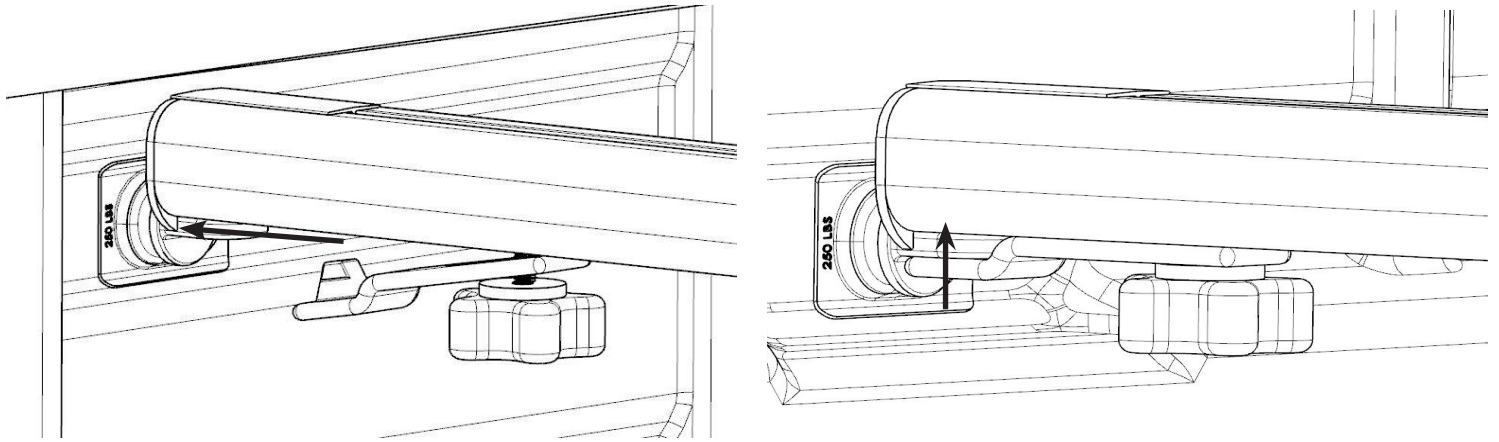

12. Apriete a mano las perillas lo más cerca a los amarres como sea posible para retención máxima. Verifique que ambos lados estén asegurados. El ensamble está completo.

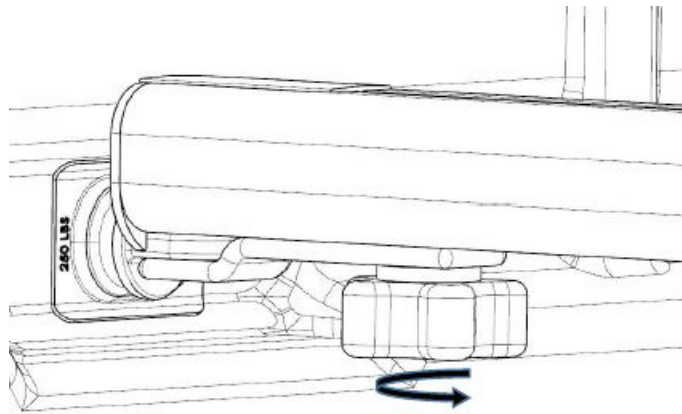

31XX Cargo Divider Panel Kit

IR 18NO14

PART NO. **23286043**

SHEET **15** OF **15**

ALL INFORMATION WITHIN ABOVE BORDER TO BE PRINTED EXACTLY AS SHOWN ON 8.5 x 11 WHITE 16 POUND NON-BOND RECYCLABLE PAPER. PRINT ON BOTH SIDES, EXCLUDING TEMPLATES. TO BE UNITIZED IN ACCORDANCE WITH GM SPECIFICATIONS.

DATE	REVISION	AUTH	DR
18NO14	Initial Release - Kyle Kakstis	2116376	

INSTALLATION INSTRUCTIONS	
31XX Cargo Divider Panel Kit	
PART NO.	23286043
SHEET	15 OF 15