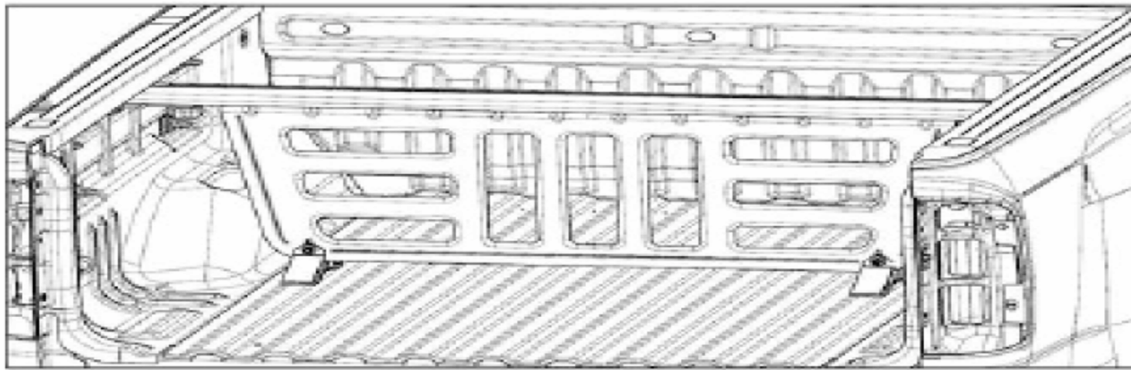

**Document ID: 4619835**

# Pickup Box Divider Divider Package Installation

**Installation Instructions Part Number**

23412054

**Procedure**

1. Cargo divider designed to retain cargo in a fixed position within the pick-up box. Can be positioned at any of the 3 upper tie down locations along the bed walls.

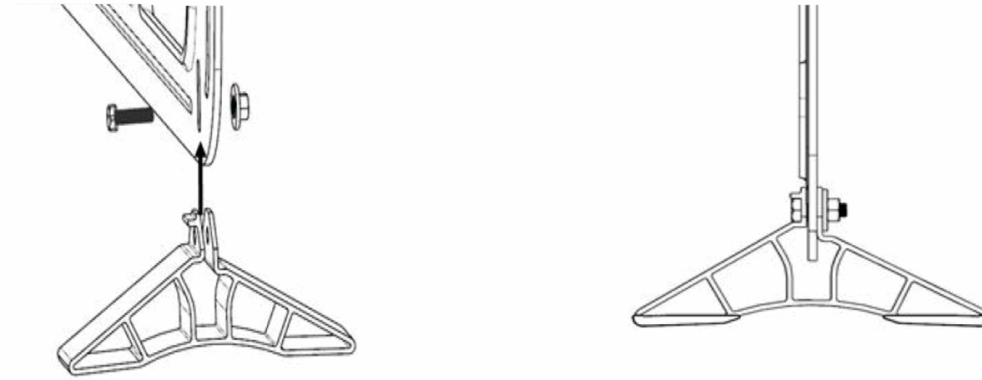

2. Slide stabilizer foot onto cargo divider panel at each corner, aligning the hole in the foot to the vertical slot in the panel. Insert MJ8 Hex Head Bolt through the hole, and loosely install the nut & washer on the opposing flat side of the stabilizer foot. **Do not tighten.**

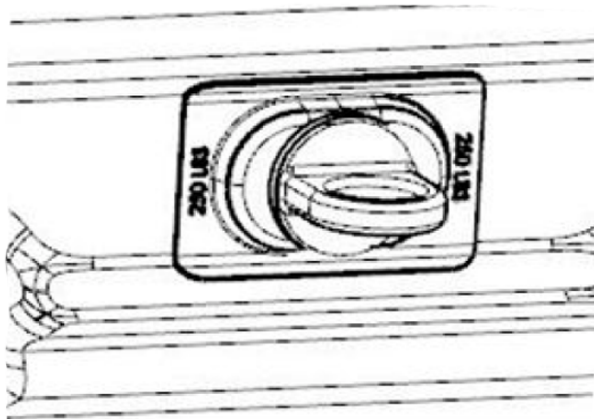

3. Prior to assembly, ensure tie downs are tightened and oriented horizontally.

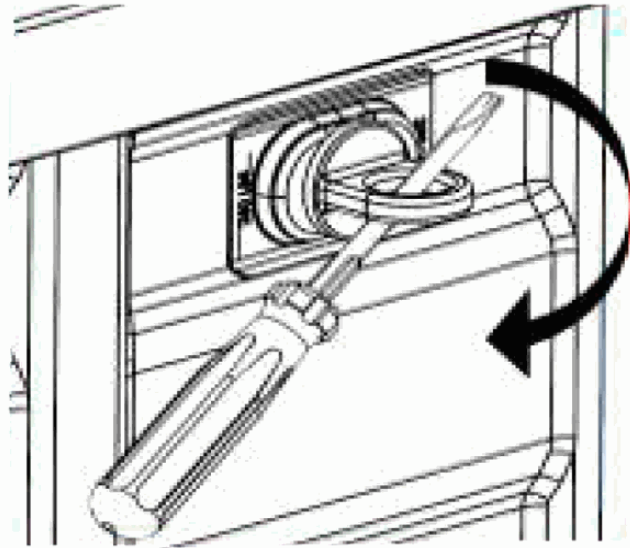

4. After hand tightening the tie down, insert a hand tool such as a screwdriver or ratchet extension through the loop to tighten 1 to 2 half turns further.

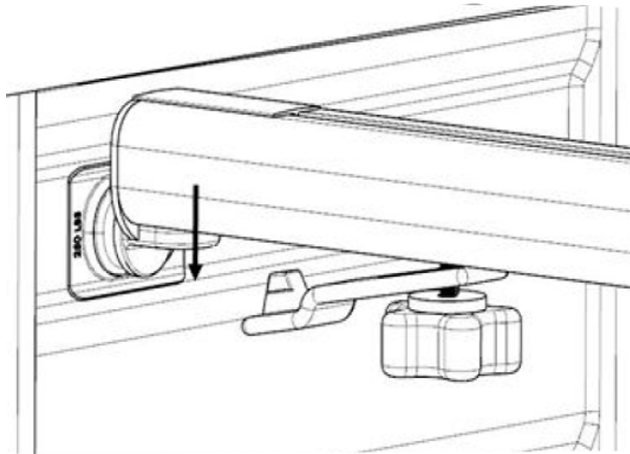

5. With the end caps pointed down and the protectant strips facing up, place the cargo divider on top of each of the opposing tie down loops.

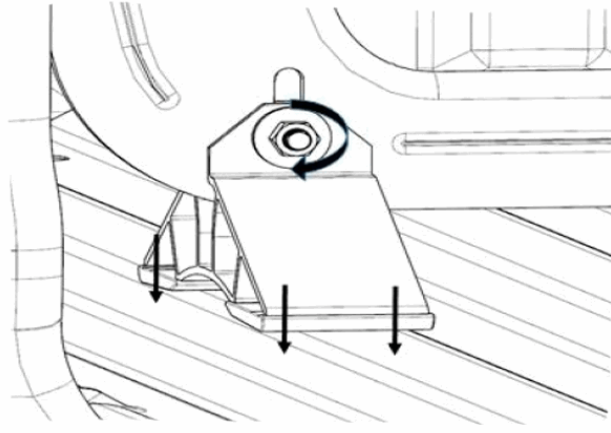

6. With cargo divider resting on top of the tie downs, push stabilizer foot down so that both legs rest flat against the pick up bed floor.  
Tighten the nut while maintaining downward pressure on the stabilizer foot. Repeat for adjacent stabilizer foot.