

Accessory Engine Cover Installation

Application	Part Number
LTG 4 Cylinder	12663899, 12663900, 12663901
LGX 6 Cylinder	12663903, 12663904, 12663905
LT1 8 Cylinder	12669894, 12669895, 12669896

LTG – remove oil fill cap (1) then remove attaching screw (2). Lift up cover (3). Reinstall screw at 9 N·m (80 lb in)

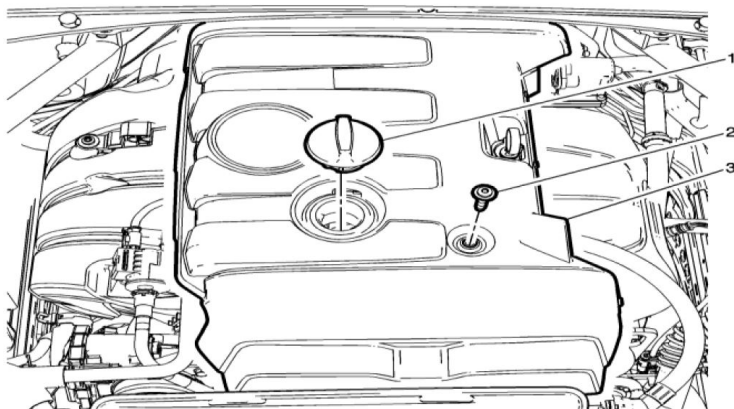

LGX - Remove oil fill cap and lift cover to remove. Engage rear attaching clips when reinstalling and reinstall oil fill cap.



LT1 - Remove Left and Right side cover by pulling upwards and disengaging the grommets from the studs.

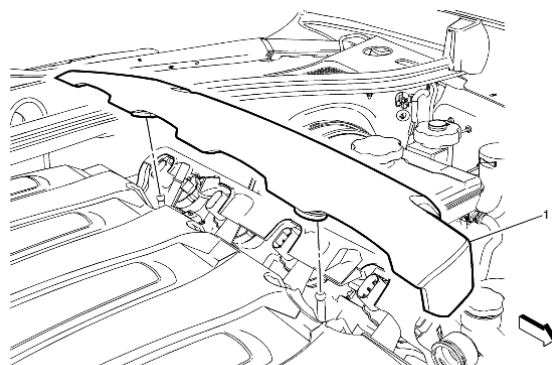
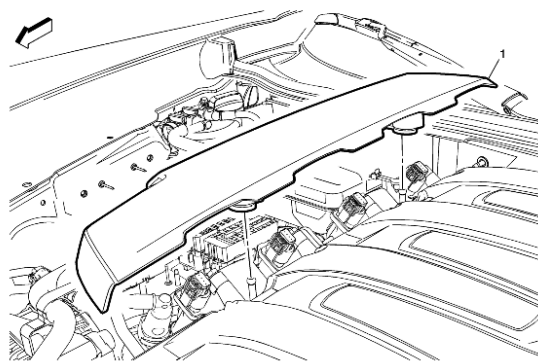

Remove 4 intake manifold cover studs and then unplug MAP sensor and wiring harness attachments.

Remove intake manifold cover.

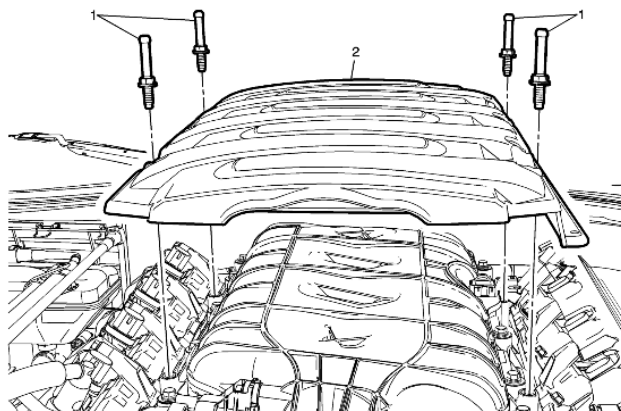

Install accessory intake manifold cover and reinstall intake manifold cover studs and tighten to 10 NM (89 lb-in) and reattach MAP sensor and wiring harness attachments.

Install accessory left hand and right hand covers by pressing onto ball studs

Camaro Accessory Engine Cover Instructions

IR 13AP15 PART NO. **12669900** SHEET **1** OF **3**

ALL INFORMATION WITHIN ABOVE BORDER TO BE PRINTED EXACTLY AS SHOWN ON 8.5 x 11 WHITE 16 POUND NON-BOND RECYCLABLE PAPER. PRINT ON BOTH SIDES, EXCLUDING TEMPLATES. TO BE UNITIZED IN ACCORDANCE WITH GM SPECIFICATIONS.

DATE	REVISION	AUTH	DR
13AP15	Initial Release - Thomas Wysocki	2086474	

TITLE	INSTALLATION INSTRUCTIONS		
Camaro Accessory Engine Cover Instructions			
PART NO.	12669900		SHEET 1 OF 3

Pose du couvercle accessoire de moteur

Application	Numéro de pièce
LTG 4 cylindres	12663899, 12663900, 12663901
LGX 6 cylindres	12663903, 12663904, 12663905
LT1 8 cylindres	12669894, 12669895, 12669896

LTG – Déposer le bouchon de remplissage d'huile (1) puis déposer la vis de fixation (2). Lever le couvercle (3). Reposer la vis en la serrant à 9 Nm (80 lb po)

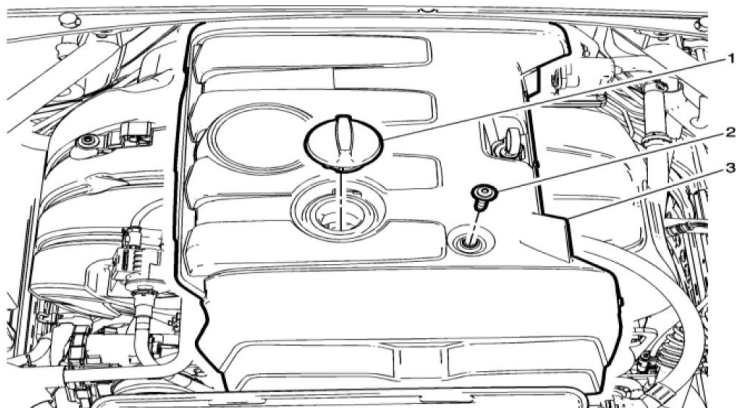

LGX – Déposer le bouchon de remplissage d'huile puis lever le couvercle pour le déposer. Engager les clips de fixation arrière pour la repose et reposer le bouchon de remplissage d'huile.



LT1 – Déposer les couvercles gauche et droit en tirant vers le haut et en dégageant les rondelles isolantes des goujons.

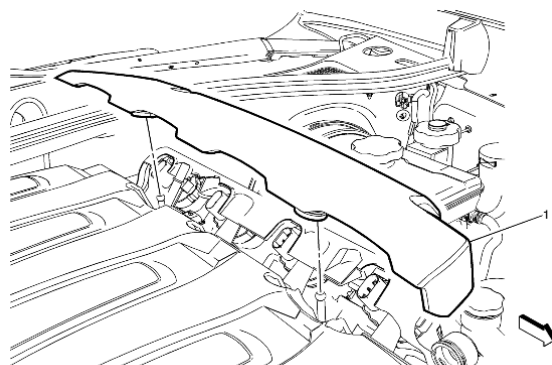
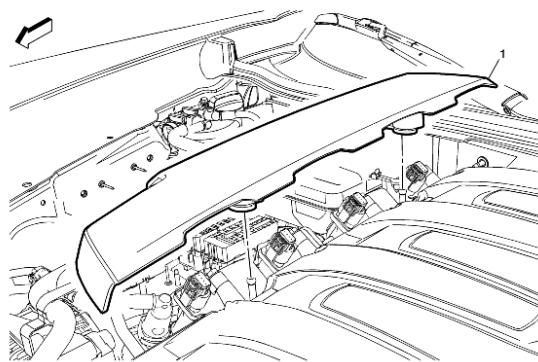

Déposer 4 goujons de couvercle de tubulure d'admission, puis débrancher le capteur de pression absolue de tubulure d'admission (MAP) et les fixations de faisceau de câbles.

Déposer le couvercle de tubulure d'admission.

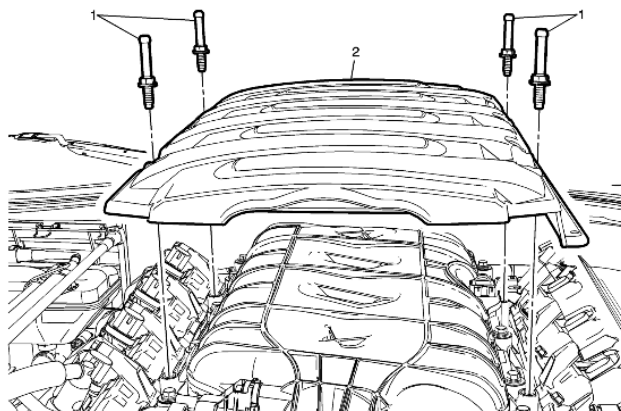

Poser le couvercle de tubulure d'admission accessoire et reposer les goujons de couvercle de tubulure d'admission, puis les serrer à 10 Nm (89 lb-po) et reposer le capteur MAP et les fixations de faisceau de câbles.

Poser les couvercles gauche et droit accessoires en les pressant sur les goujons.

DATE	REVISION	AUTH	DR
13AP15	Initial Release - Thomas Wysocki	2086474	

TITLE	INSTALLATION INSTRUCTIONS		
Camaro Accessory Engine Cover Instructions			
PART NO.	12669900	SHEET	2 OF 3

Instalación de cubierta del motor de accesorios

Aplicación	Número de parte
LTG 4 cilindros	12663899, 12663900, 12663901
LGX 6 cilindros	12663903, 12663904, 12663905
LT1 8 cilindros	12669894, 12669895, 12669896

LTG – Retire la tapa de relleno de aceite (1) y después retire el tornillo de sujeción (2). Levante la cubierta (3). Vuelva a instalar el tornillo a 9 N·m (80 lbs pulg.)

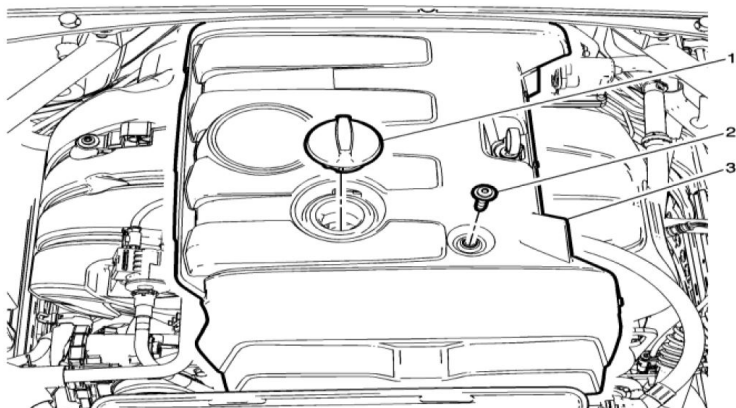

LGX – Retire la tapa de relleno de aceite y levante la cubierta para retirarla. Conecte los sujetadores de conexión traseros cuando vuelva a instalar y vuelva a instalar la tapa de relleno de aceite.



LT1 – Retire la cubierta del lado izquierdo y derecho jalando hacia arriba y desconectando los pasacables de los pernos.

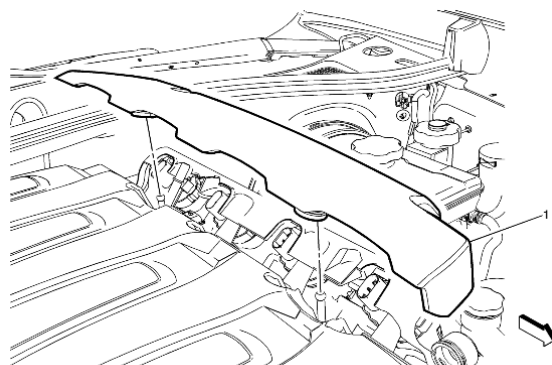
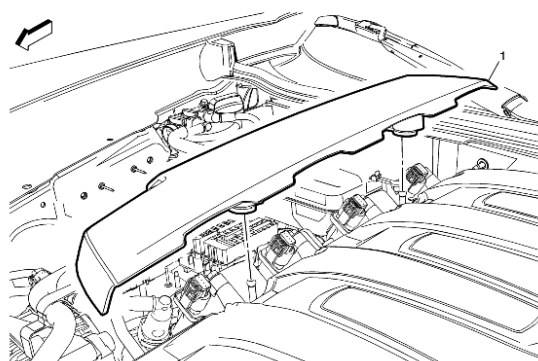

Retire los 4 pernos de la cubierta del múltiple de admisión y después desconecte el sensor MAP y las conexiones del arnés de cableado.

Retire la cubierta del múltiple de admisión.

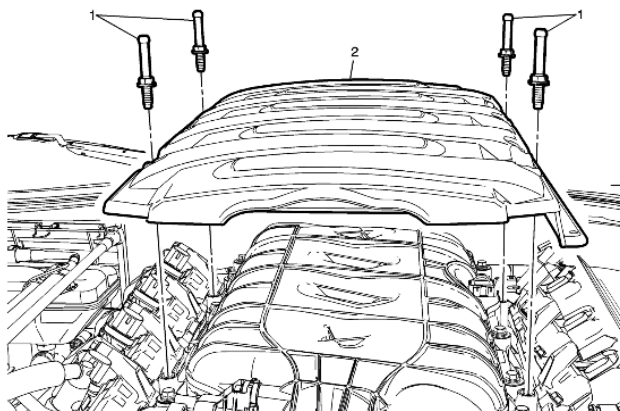

Instale la cubierta del múltiple de admisión de accesorios y vuelva a instalar los pernos de la cubierta del múltiple de admisión y apriete a 10 N·m (89 lbs pulg.) y vuelva a conectar el sensor de MAP y las conexiones del arnés de cableado.

Instale las cubiertas izquierda y derecha de accesorios presionando sobre las rótulas

Camaro Accessory Engine Cover Instructions

IR 13AP15 PART NO. **12669900** SHEET **3** OF **3**

ALL INFORMATION WITHIN ABOVE BORDER TO BE PRINTED EXACTLY AS SHOWN ON 8.5 x 11 WHITE 16 POUND NON-BOND RECYCLABLE PAPER. PRINT ON BOTH SIDES, EXCLUDING TEMPLATES. TO BE UNITIZED IN ACCORDANCE WITH GM SPECIFICATIONS.

DATE	REVISION	AUTH	DR
13AP15	Initial Release - Thomas Wysocki	2086474	

TITLE	INSTALLATION INSTRUCTIONS		
Camaro Accessory Engine Cover Instructions			
PART NO.	12669900	SHEET	3 OF 3