

Accessory Splash Guard Rear Kit

Please read instructions thoroughly before starting.

Installation time: 30 minutes

Package Contents

Description	Quantity
Left-hand Splash Guard	1
Right-hand Splash Guard	1
M4.2 Screws	2
M4.2 U-Nut	2
Alcohol Wipes	2
Instruction Sheet	1

Tools Required

- 3/16" (5mm) Drill Bit / Drill
- T20 Torx Screwdriver
- Clean Cloth / Rag

Installation Procedure

1. Clean and degrease body panel where splash guards are to be located.
2. Using alcohol wipes, clean area to be taped.
3. Parts and vehicle temperature must be between 60°F and 109°F (15°C and 43°C).
4. Remove existing screws, locations **A** and **B**. See Figure 1.
5. Mount splash guard and reinstall existing screws in locations **A** and **B**, tighten while holding part up and into bumper panel. See Figure 1.
6. While holding splash guard firmly against panel, drill 3/16" (5mm) hole in location **C** using part as a template. See Figure 1.
7. Pull part out slightly at location **C**, install supplied U-Nut, over drilled hole with turned up edge on inside of panel. See figure 1 and 2.
8. While holding splash guard firmly against body panel, install supplied screw in location **C** and tighten. See Figure1.
9. Push forward on splash guard and pull tape liner off and apply 20-30 pounds of pressure along tape length to ensure contact.
10. Repeat procedure for other side.
11. Guards can be cleaned with any commercially available cleaner.

Figure 1

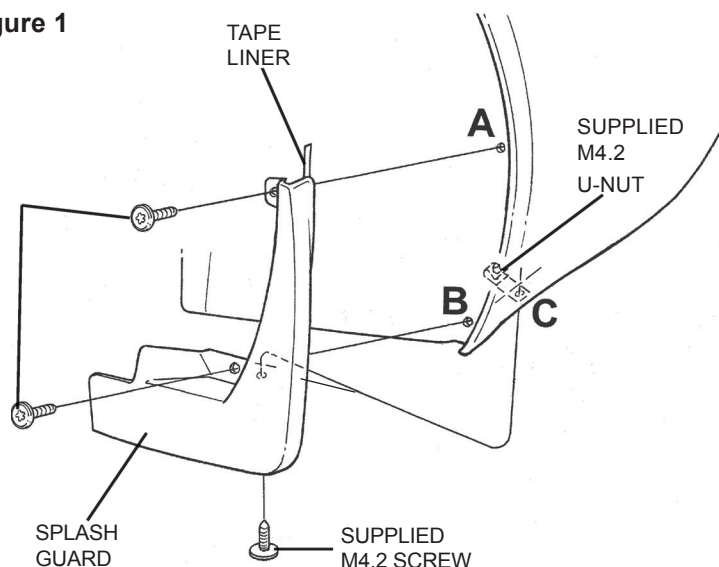
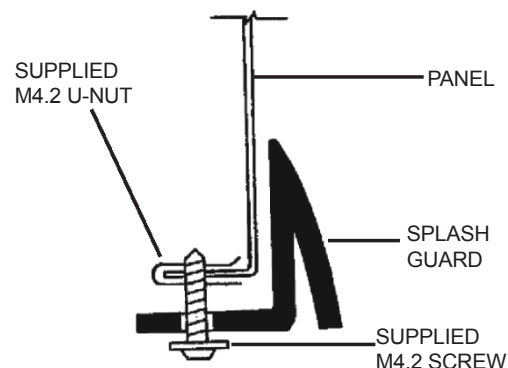

Figure 2



NOTE: INSTALL SUPPLIED U-NUT WITH TURNED UP EDGE ON INSIDE OF PANEL EDGE.

Accessory Splash Guard Rear Kit

IR 02JA13

PART NO.

22878777

SHEET **1** OF **4**

ALL INFORMATION WITHIN ABOVE BORDER TO BE PRINTED EXACTLY AS SHOWN ON 8.5 x 11 WHITE 16 POUND NON-BOND RECYCLABLE PAPER. PRINT ON BOTH SIDES, EXCLUDING TEMPLATES. TO BE UNUNITIZED IN ACCORDANCE WITH GM SPECIFICATIONS.

DATE	REVISION	AUTH	DR
02JA13	Initial Release - Carlos Martinez	FYTXSB	

TITLE
INSTALLATION INSTRUCTIONS Accessory Splash Guard Rear Kit
PART NO. 22878777 SHEET 1 OF 4

Trousse de bavette garde-boue arrière accessoire

Lire attentivement les directives avant de commencer.

Durée de l'installation : 30 minutes

Contenu de l'ensemble

Description	Quantité
Bavette garde-boue gauche	1
Bavette garde-boue droit	1
Vis M4.2	2
Écrou en U M4.2	2
Tampons d'alcool	2
Feuille de directives	1

Outils nécessaires

- Perceuse et mèche de 3/16 po (5 mm)
- Tournevis T20 Torx
- Chiffon propre

Procédure d'installation

- Nettoyer et dégraisser le panneau de carrosserie où seront installés les bavettes garde-boue.
- Utiliser un tampon à l'alcool pour nettoyer la zone d'application du ruban adhésif.
- La température des pièces et du véhicule doit se situer entre 15 °C et 43 °C (60 °F et 109 °F).
- Déposer les vis existantes situées aux emplacements **A** et **B**. Voir la figure 1.
- Monter la bavette garde-boue et reposer les vis existantes aux emplacements **A** et **B**, serrer tout en tenant la pièce vers le haut et dans le panneau de pare-chocs. Voir la figure 1.
- Tout en maintenant fermement la bavette garde-boue contre le panneau, percer un trou de 3/16 po (5 mm) à l'emplacement **C** en utilisant la pièce comme gabarit. Voir la figure 1.
- Sortir légèrement la pièce à l'emplacement **C** et poser l'écrou en U fourni par-dessus le trou percé en plaçant le bord retourné à l'intérieur du panneau. Voir les figures 1 et 2.
- Tout en maintenant fermement la bavette garde-boue contre le panneau de carrosserie, poser la vis fournie à l'emplacement **C** et serrer. Voir la figure 1.
- Pousser la bavette garde-boue vers l'avant, enlever la doublure du ruban et appliquer une pression de 20 à 30 livres sur la longueur du ruban pour qu'il colle bien.
- Refaire la même chose de l'autre côté.
- Les bavettes garde-boue peuvent être nettoyées avec n'importe quel produit de nettoyage vendu dans le commerce.

Figure 1

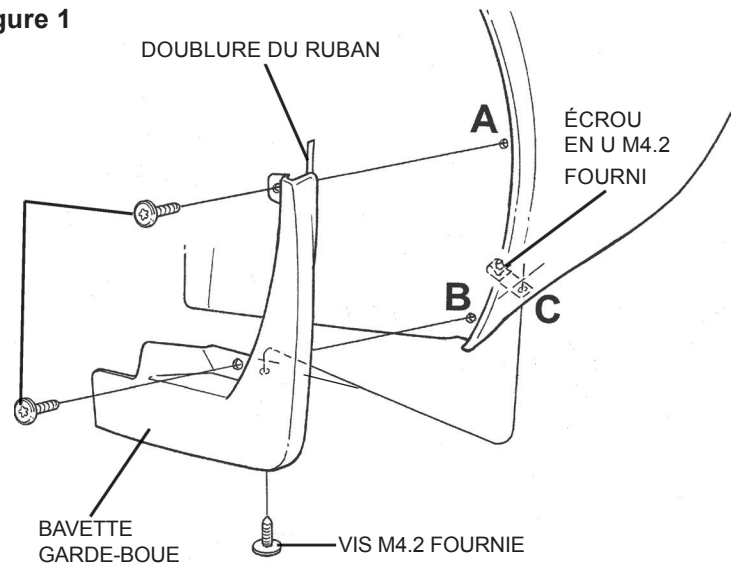
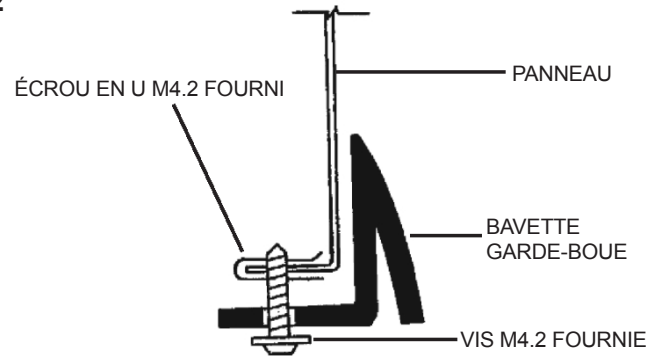

Figure 2



REMARQUE : POSER L'ÉCROU EN U FOURNI EN PLAÇANT LE BORD RETOURNÉ À L'INTÉRIEUR DU BORD DU PANNEAU.

Accessory Splash Guard Rear Kit

IR 02JA13

PART NO.

22878777

SHEET **2** OF **4**

ALL INFORMATION WITHIN ABOVE BORDER TO BE PRINTED EXACTLY AS SHOWN ON 8.5 x 11 WHITE 16 POUND NON-BOND RECYCLABLE PAPER. PRINT ON BOTH SIDES, EXCLUDING TEMPLATES. TO BE UNUNITIZED IN ACCORDANCE WITH GM SPECIFICATIONS.

DATE	REVISION	AUTH	DR

TITLE	PART NO.	SHEET	OF
INSTALLATION INSTRUCTIONS Accessory Splash Guard Rear Kit	22878777	2	4

Juego trasero de salpicadera opcional

Por favor lea las instrucciones minuciosamente antes de comenzar.

Tiempo de instalación: 30 minutos

Contenido del paquete

Descripción	Cantidad
Salpicadera izquierda	1
Salpicadera derecha	1
Tornillos M4.2	2
Tuerca U M4.2	2
Toallas con Alcohol	2
Hoja de Instrucciones	1

Herramientas Requeridas

- Broca/taladro de 3/16" (5mm)
- Destornillador Torx T20
- Tela / Estopa Limpia

Procedimiento de instalación

1. Limpie y desengrase el tablero de la carrocería donde se van a ubicar los guardabarros.
2. Con toallas con alcohol, limpie el área a la que se aplicará cinta.
3. La temperatura de las partes y del vehículo debe estar entre 60°F y 109°F (15°C y 43°C).
4. Retire los tornillos existentes, ubicaciones **A** y **B**.
Vea la figura 1.
5. Monte la salpicadera y vuelva a instalar los tornillos existentes en las ubicaciones **A** y **B**, apriete mientras sostiene la parte hacia arriba y dentro del tablero de la defensa. Ver la Figura 1.
6. Mientras sujeta la salpicadera firmemente contra el tablero, perfora un orificio de 3/16" (5mm) en la ubicación **C** usando la parte como plantilla. Ver la Figura 1.
7. Jale la parte ligeramente en la ubicación **C**, instale la tuerca U incluida, sobre el orificio perforado con el borde hacia arriba dentro del tablero. Vea la figura 1 y 2.
8. Mientras sostiene la salpicadera firmemente contra el tablero de la carrocería, instale el tornillo suministrado en la ubicación **C** y apriete. Ver la Figura 1.
9. Empuje hacia delante sobre la salpicadera, quite el revestimiento de la cinta y aplique de 20-30 libras de presión a lo largo de la cinta para asegurar el contacto.
10. Repita el procedimiento para el otro lado.
11. Las protecciones se pueden limpiar con cualquier limpiador disponible comercialmente.

Figura 1



Figura 2



NOTA: INSTALE LA TUERCA U INCLUIDA CON EL BORDE VIENDO HACIA ARRIBA EN EL INTERIOR DEL BORDE DEL TABLERO.

Accessory Splash Guard Rear Kit

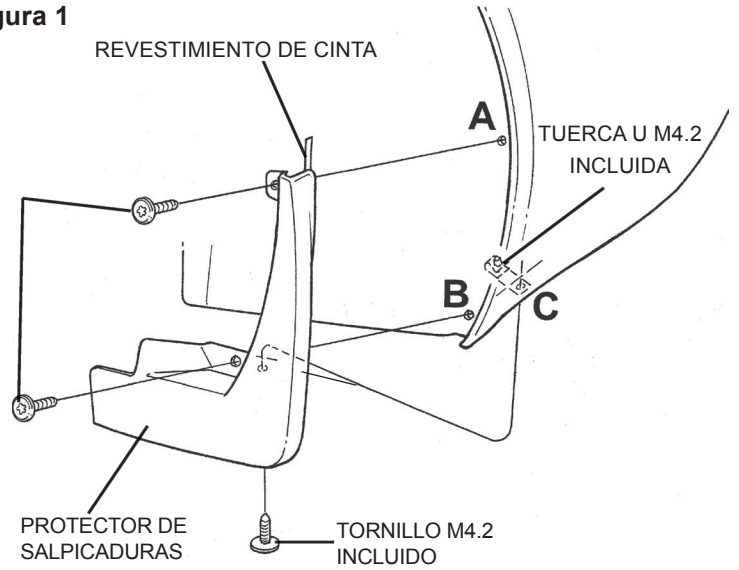
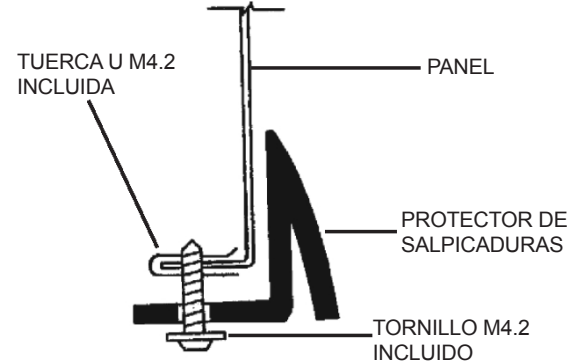
IR 02JA13

PART NO.

22878777

SHEET **3** OF **4**

ALL INFORMATION WITHIN ABOVE BORDER TO BE PRINTED EXACTLY AS SHOWN ON 8.5 x 11 WHITE 16 POUND NON-BOND RECYCLABLE PAPER. PRINT ON BOTH SIDES, EXCLUDING TEMPLATES. TO BE UNUNITIZED IN ACCORDANCE WITH GM SPECIFICATIONS.

DATE	REVISION	AUTH	DR

TITLE	PART NO.	SHEET	OF
INSTALLATION INSTRUCTIONS Accessory Splash Guard Rear Kit	22878777	3	4

后挡泥板附件包

在开始前请通读说明。

安装时间：30分钟

包装内的物品

名称	数量
左侧挡泥板	1
右侧挡泥板	1
M4.2 螺钉	2
M4.2 U形螺母	2
酒精湿巾	2
说明表	1

必备工具

- 3/16" (5mm) 钻头/钻机
- T20 内梅花头螺丝刀
- 清洁布/抹布

安装规程

1. 清洁并对需要安装挡泥板的车身面板区域去油污。
2. 使用酒精湿巾清洁需要贴胶带的区域。
3. 零件和车辆温度必须在60° F和109° F (15° C和43° C) 之间。
4. 拆除现有的螺钉，图中位置A和B。请参阅图1。
5. 安装挡泥板并将现有的螺钉重新安装到图中位置A和B中，将零件向上固定的同时拧入保险杠面板中。请参阅图1。
6. 在将挡泥板牢牢固定到面板的同时，使用零件在图中位置C中钻出3/16" (5mm) 的孔作为模板。请参阅图1。
7. 在图中位置C将零件稍微拉出，安装提供的U形螺母，盖住钻好的孔，同时螺母卷起的边缘位于面板内侧上。请参阅图1和2。
8. 将挡泥板牢牢固定到车身面板上的同时，将提供的螺钉安装到图中位置C中并拧紧。请参阅图1。
9. 向前推动挡泥板，并撕下胶带条，然后沿着胶带长度施加20-30磅的压力以确保完全接触。
10. 在另一侧重复相同程序。
11. 可用任何市场上购买的清洁剂清洁挡泥板。

图1



图2



注意：安装提供的U形螺母时，螺母卷起的边缘位于面板边缘内侧上。

Accessory Splash Guard Rear Kit

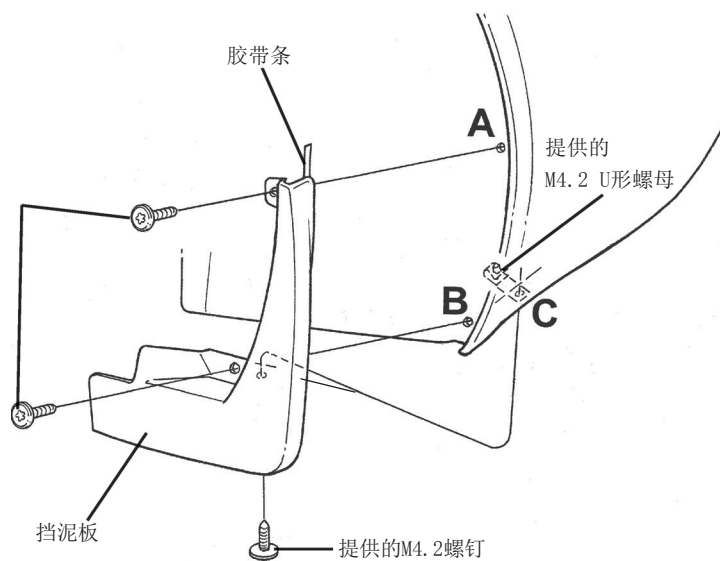
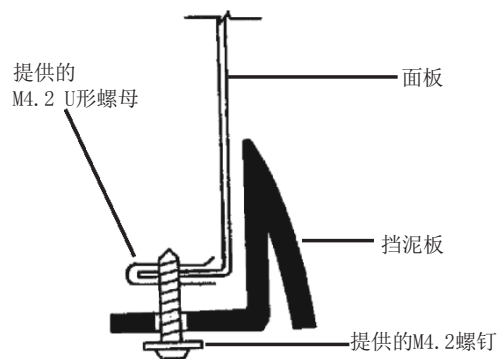
IR 02JA13

PART NO.

22878777

SHEET 4 OF 4

ALL INFORMATION WITHIN ABOVE BORDER TO BE PRINTED EXACTLY AS SHOWN ON 8.5 x 11 WHITE 16 POUND NON-BOND RECYCLABLE PAPER. PRINT ON BOTH SIDES, EXCLUDING TEMPLATES. TO BE UNITIZED IN ACCORDANCE WITH GM SPECIFICATIONS.

DATE	REVISION	AUTH	DR

TITLE
INSTALLATION INSTRUCTIONS
Accessory Splash Guard Rear Kit

PART NO.

22878777

SHEET 4 OF 4