

GMC Acadia Splash Guard - Rear

Please read instructions thoroughly before starting.

Installation Time

Approximately 30 minutes.

Tools Required

- T15 Torx Screw Driver
- Drill
- 13/64" (5.0 mm) Drill Bit
- 1/8" (3.0 mm) Drill Bit
- Clean Cloth/Rag

Package Contents

Description	Quantity
Left Hand Splash Guard	1
Right Hand Splash Guard	1
M4.2 x 20 Self-tapping Screw	6
U-nut	6
Instruction Sheet	1

Installation Procedure

1. Remove rear tire.
2. Clean and degrease body panel where splash guards are to be located.
3. Remove screw from location (A) of rear fascia. Retain fastener. **See Fig. 1.**
4. Align splash guard to vehicle and reinstall screw at location (A).
5. While holding splash guard firmly against fascia drill 13/64" (5.0 mm) holes at locations (B) and (C). Drill through liner and fascia.
6. Remove fastener from locations (A) and (D) as well as the splash guard.
7. Attach U-nuts to fascia over drilled holes at (B) and (C) and reposition liner to original location. **See Fig. 2.**
8. Reinstall screw at location (D) to reattach the liner to the fascia.
9. Align splash guard to fascia and install screws at locations (A), (B) and (C) while holding the splash guard against the panel to minimize gaps. **See Fig. 3.**
10. Drill 1/8" hole at location (E).
11. Install screw and clip (as a nut) at location (E). Clip should be located above panel and not clipped onto the fascia or liner. **See Fig. 2 and Fig. 4.**
12. Repeat procedure for the other side.
13. Guards can be cleaned with any commercially available cleaner.

FIGURE 1

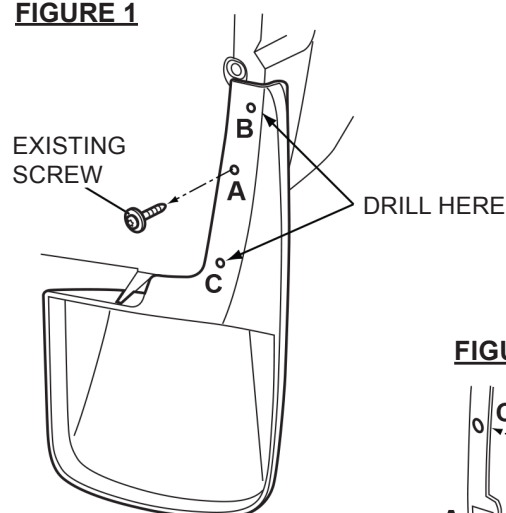

FIGURE 2

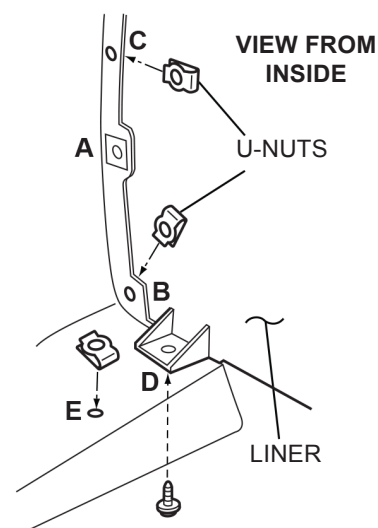

FIGURE 3

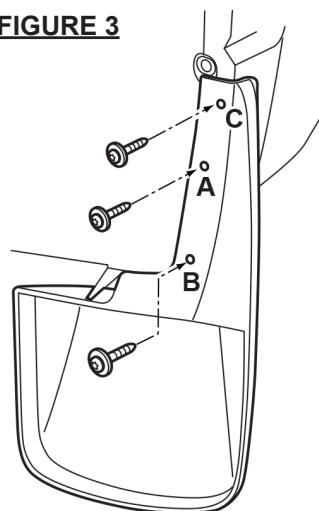
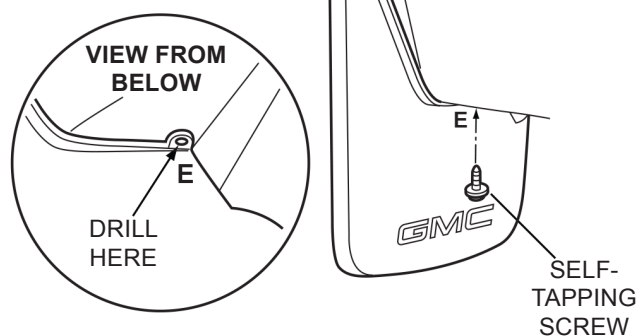

FIGURE 4



Acadia Splash Guard—Rear

IR 12JL13

PART NO.

22936062

SHEET

1 OF **3**

ALL INFORMATION WITHIN ABOVE BORDER TO BE PRINTED EXACTLY AS SHOWN ON 8.5 x 11 WHITE 16 POUND NON-BOND RECYCLABLE PAPER. PRINT ON BOTH SIDES, EXCLUDING TEMPLATES. TO BE UNITIZED IN ACCORDANCE WITH GM SPECIFICATIONS.

DATE	REVISION	AUTH	DR
12JL13	Initial Release - Vinay Saini	1891986	

TITLE	PART NO.	SHEET	OF
INSTALLATION INSTRUCTIONS Acadia Splash Guard—Rear	22936062	1	3

Bavette garde-boue GMC Acadia – Arrière
Lire attentivement les directives avant de commencer.

Temps de pose

Environ 30 minutes.

Outils nécessaires

- Tournevis Torx T15
- Perceuse
- Mèche de 13/64 po (5,0 mm)
- Mèche de 1/8 po (3,0 mm)
- Chiffon propre

Contenu de l'ensemble

Désignation	Quantité
Bavette garde-boue gauche	1
Bavette garde-boue droit	1
Vis autotaraudeuse M4,2 x 20	6
Écrou en U	6
Feuille de directives	1

Procédure d'installation

1. Déposer le pneu arrière.
2. Nettoyer et dégraisser le panneau de carrosserie où seront posées les bavettes garde-boue.
3. Retirer la vis de l'emplacement (A) du carénage arrière. Conserver la fixation. Voir la Fig. 1.
4. Aligner la bavette garde-boue sur le véhicule et reposer la vis à l'emplacement (A).
5. Tenir fermement la bavette garde-boue contre le carénage et percer des trous de 13/64 po (5,0 mm) aux emplacement (B) et (C). Percer la doublure et le carénage.
6. Retirer la fixation des emplacements (A) et (D), ainsi que la bavette garde-boue.
7. Fixer les écrous en U au carénage sur les trous percés (B) et (C) et repositionner la doublure à l'emplacement d'origine. Voir la Fig. 2.
8. Reposer la vis à l'emplacement (D) pour fixer la doublure au carénage.
9. Aligner la bavette garde-boue sur le carénage et poser les vis aux emplacements (A), (B) et (C) en tenant la bavette garde-boue contre le panneau pour réduire les espaces. Voir la Fig. 3.
10. Percer un trou de 1/8 po à l'emplacement (E).
11. Poser la vis et l'agrafe (comme écrou) à l'emplacement (E). L'agrafe doit être située au-dessus du panneau et non sur le carénage ou la doublure. Voir Fig. 2 et Fig. 4.
12. Refaire la même chose de l'autre côté.
13. Les bavettes garde-boue peuvent être nettoyées avec n'importe quel produit de nettoyage vendu dans le commerce.

FIGURE 1

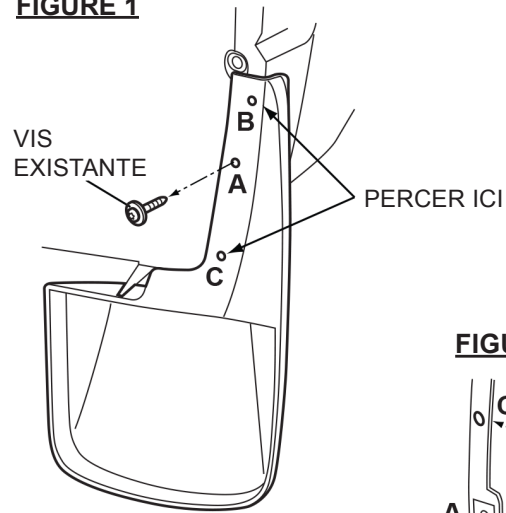

FIGURE 2

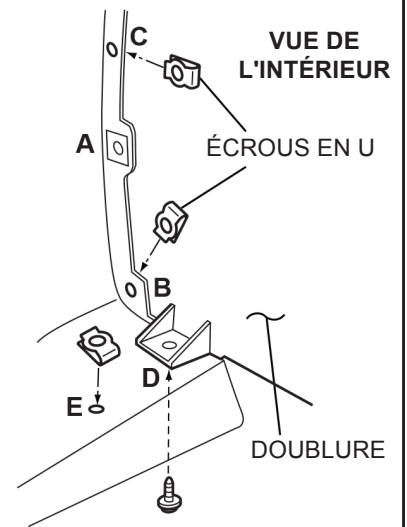

FIGURE 3

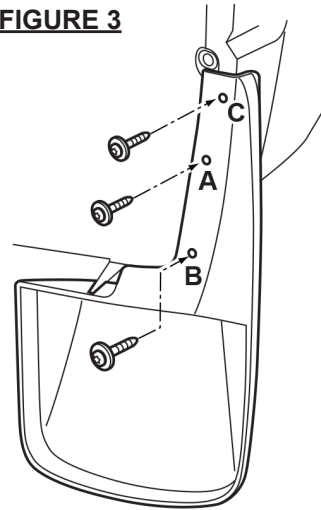
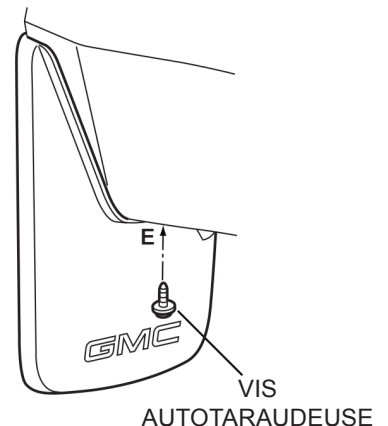
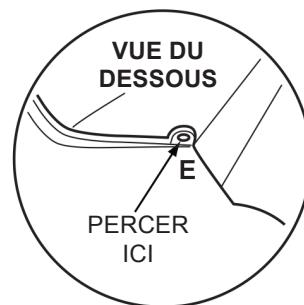

FIGURE 4



ALL INFORMATION WITHIN ABOVE BORDER TO BE PRINTED EXACTLY AS SHOWN ON 8.5 x 11 WHITE 16 POUND NON-BOND RECYCLABLE PAPER. PRINT ON BOTH SIDES, EXCLUDING TEMPLATES. TO BE UNITIZED IN ACCORDANCE WITH GM SPECIFICATIONS.

DATE	REVISION	AUTH	DR
12JL13	Initial Release - Vinay Saini	1891986	

TITLE	INSTALLATION INSTRUCTIONS Acadia Splash Guard—Rear		
PART NO.	22936062	SHEET	2 OF 3

Salpicadera GMC Acadia - Trasera

Por favor lea las instrucciones minuciosamente antes de comenzar.

Tiempo de instalación

Aproximadamente 30 minutos.

Herramientas Requeridas

- Destornillador Torx T15
- Taladro
- Broca de 13/64" (5.0 mm)
- Broca de 1/8" (3.0 mm)
- Tela/Estopa Limpia

Contenido del paquete

Descripción	Cantidad
Salpicadera izquierda	1
Salpicadera derecha	1
Tornillo autorroscante M4.2 x 20	6
Tuerca U	6
Hoja de Instrucciones	1

Procedimiento de instalación

1. Retire la llanta trasera.
2. Limpie y desengrase el tablero de la carrocería donde se van a ubicar los guardabarros.
3. Retire el tornillo de la ubicación (A) de la fascia trasera. Retenga el sujetador. **Vea la Fig. 1.**
4. Alinee la salpicadera al vehículo y vuelva a instalar el tornillo en la ubicación (A).
5. Mientras sostiene la salpicadera firmemente contra la fascia perfore orificios de 13/64" (5.0 mm) en las ubicaciones (B) y (C). Perfore a través del revestimiento y la fascia.
6. Retire el sujetador de las ubicaciones (A) y (D) así como la salpicadera.
7. Sujete las tuercas U a la fascia sobre los orificios perforados en (B) y (C) y vuelva a colocar el revestimiento a la ubicación original. **Vea la Fig. 2.**
8. Vuelva a instalar el tornillo en la ubicación (D) para volver a sujetar el revestimiento a la fascia.
9. Alinee la salpicadera a la fascia y vuelva a instalar los tornillos en las ubicaciones (A), (B) y (C) mientras sostiene la salpicadera contra el tablero para minimizar los espacios. **Vea la Fig. 3.**
10. Perfore el orificio de 1/8" en la ubicación (E).
11. Instale el tornillo y sujete (como una tuerca) en la ubicación (E). El sujetador se debe localizar arriba del tablero y no sujetarse sobre la fascia o revestimiento. Consulte la **Fig. 2 y Fig. 4.**
12. Repita el procedimiento para el otro lado.
13. Las protecciones se pueden limpiar con cualquier limpiador disponible comercialmente.

FIGURA 1



FIGURA 2



FIGURA 3

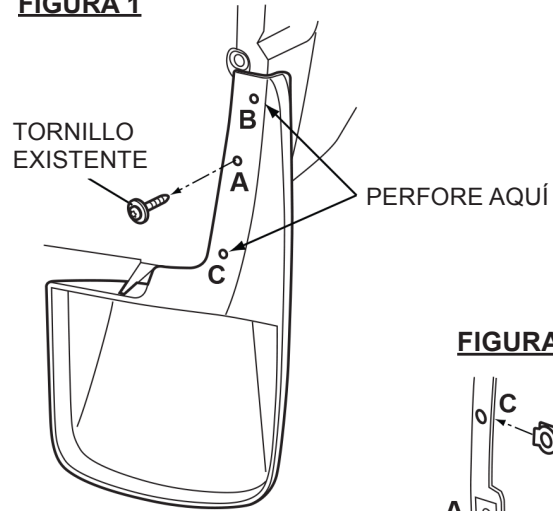

FIGURA 4

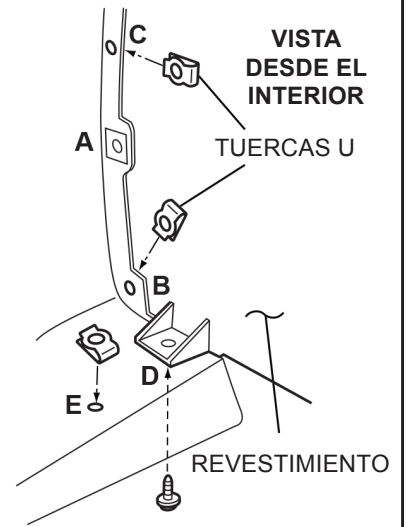
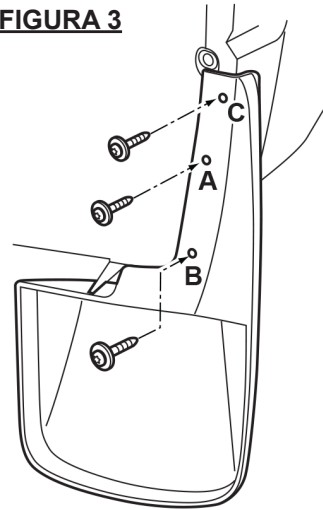
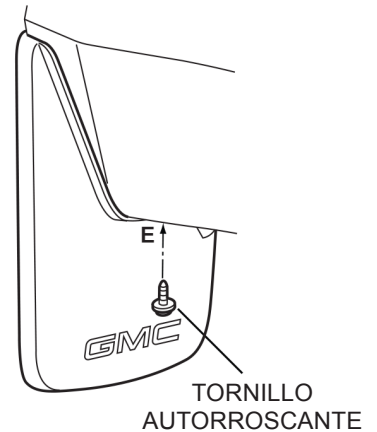

DATE	REVISION	AUTH	DR
12JL13	Initial Release - Vinay Saini	1891986	

TITLE	PART NO.	SHEET	OF
INSTALLATION INSTRUCTIONS Acadia Splash Guard—Rear	22936062	3	3