



---

## Rear Bumper Fascia Molding Package Installation

### Installation Instructions Part Number

22984893

#### Kit Contents

| Qty | Description                |
|-----|----------------------------|
| 1   | Rear Bumper Fascia Molding |
| 1   | Installation Instructions  |

### [Remove OEM Rear Bumper Fascia Molding](#)

1. Remove rear bumper fascia energy absorber from vehicle. **Refer to Vehicle Service Manual.**

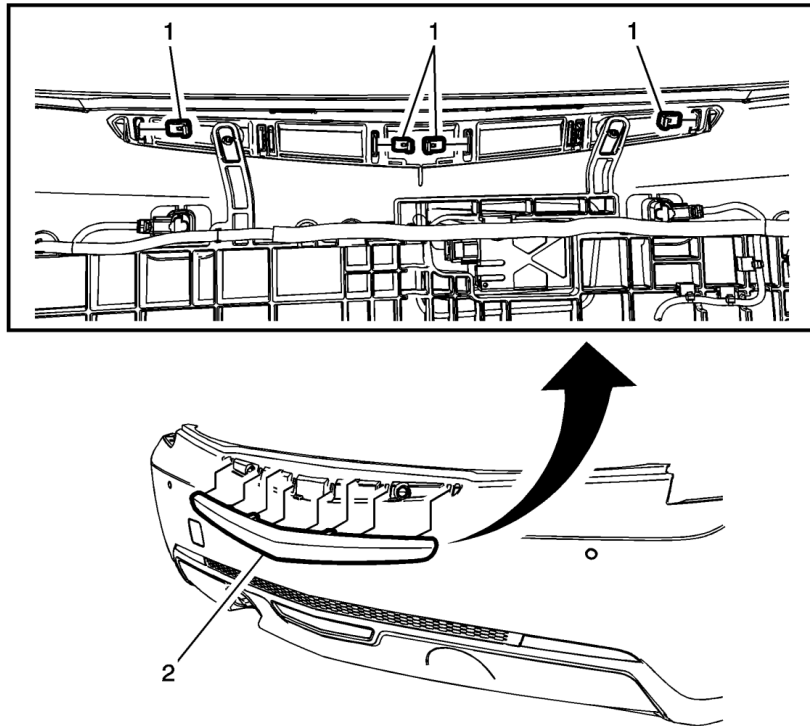

2. Remove and retain the rear bumper fascia molding push-in retainers (1).
3. Carefully push a small nylon wedge between the rear fascia and the rear fascia molding. Insert a small flat-bladed tool into the fascia slot and depress the tabs one at a time and pull on the fascia at the same time to gradually remove the rear fascia molding (2) from the rear fascia.

### **Install New Rear Bumper Fascia Molding**

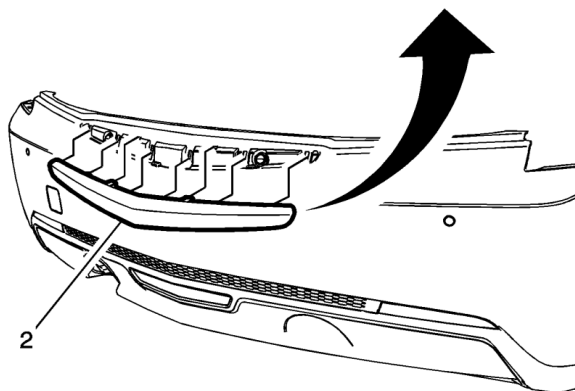
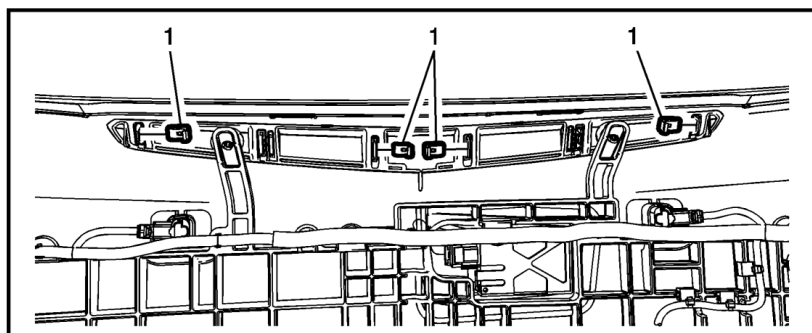

1. Install the new rear bumper fascia molding (2) the rear bumper fascia, engage retaining tabs.

**Caution:** Use the correct fastener in the correct location. Replacement fasteners must be the correct part number for that application. Fasteners requiring replacement or fasteners requiring the use of thread locking compound or sealant are identified in the service procedure. Do not use paints, lubricants, or corrosion inhibitors on fasteners or fastener joint surfaces unless specified. These coatings affect fastener torque and joint clamping force and may damage the fastener. Use the correct tightening sequence and specifications when installing fasteners in order to avoid damage to parts and systems.

2. Install the previously removed push-in retainers (1) to the rear bumper fascia molding.
3. Install the rear bumper fascia energy absorber to vehicle. **Refer to Vehicle Service Manual.**