

Assist Step Kit Installation (Bedside Assist Step LD 8 Foot / all 6 Foot 6 Inch)

[Installation Instructions Part Number](#)

23127867

Note: THIS KIT IS FOR:

- HEAVY DUTY and LIGHT DUTY 6'6" PICKUP BOX
- LIGHT DUTY 8' PICKUP BOX

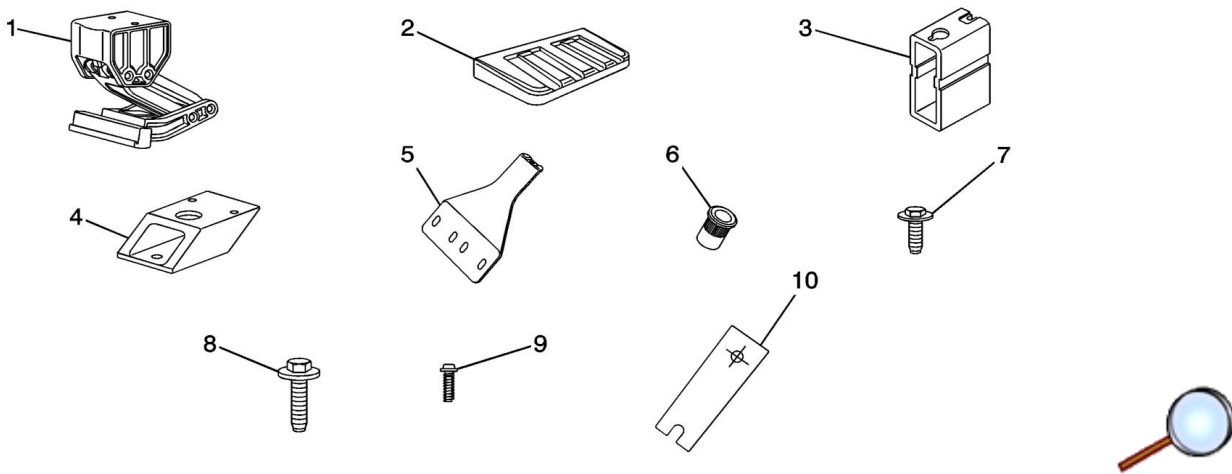

Kit Contents

Item	Description	Qty:
1	Linkage Assembly	1
2	Step Pad	1
3	Upper Mount	1
4	Lateral Mount	1
5	Frame Bracket	1
6	Rivet Nut	2
7	M8 Washered Hex Bolt	4
8	M10 Hex Bolt	2
9	M5 Delta PT Screw	3

Item	Description	Qty:
10	Drill Template	1

Tools Required

- 12" Extension
- Torque Wrench
- 13mm Swivel Socket, 15mm Socket
- 15mm Wrench
- T25 Torx Driver
- T25 Torx Bit for Torque Wrench
- Drill
- 1/8" and 17/32" Drill Bit
- Center Punch
- GM Vehicle Care Super Lube with PTFE
- Rivet Nut Installation Tool P/N: BO-42151-8mm-Kit, or equivalent

Note: Rivet Nut Installation Tool can be ordered by calling 1-800 GM Tools (468-6657) or at www.gmspecialservicetools.spx.com

Procedure

Note: Read entire instructions thoroughly before starting.

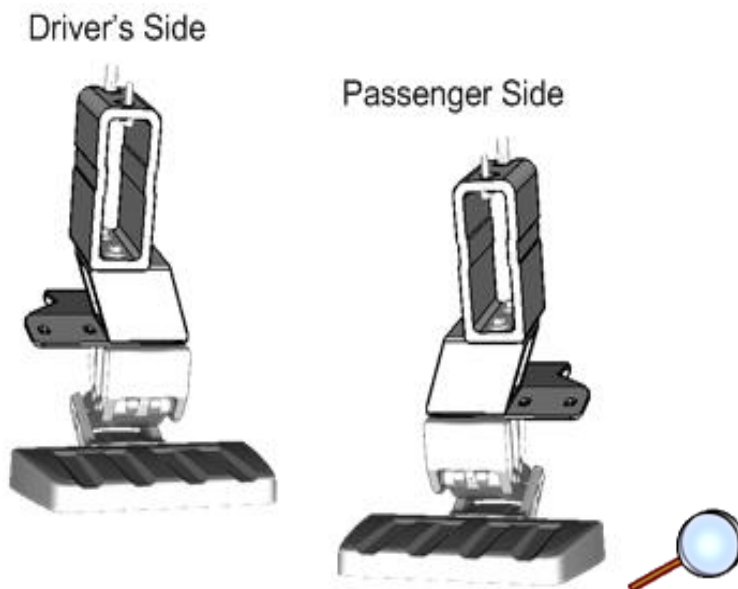

1. Brackets will be configured differently for each side of the vehicle as shown. The steps in these instructions will follow for the driver's side of the truck. Note that the passenger side will follow the same steps with a mirrored configuration.

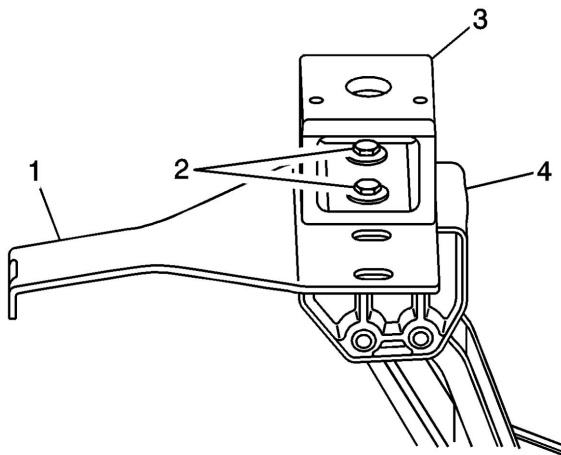

Caution: Use the correct fastener in the correct location. Replacement fasteners must be the correct part number for that application. Fasteners requiring replacement or fasteners requiring the use of thread locking compound or sealant are identified in the service procedure. Do not use paints, lubricants, or corrosion inhibitors on fasteners or fastener joint surfaces unless specified. These coatings affect fastener torque and joint clamping force and may damage the fastener. Use the correct tightening sequence and specifications when installing fasteners in order to avoid damage to parts and systems.

- Using a 15mm socket, assemble lateral mount (3) onto linkage assembly (4) with M10 hex bolts (2). Steel frame bracket (1) is to be assembled between linkage assembly (4) and lateral mount (3). Do not tighten bolts yet.

Note: Driver's side configuration shown, see step 1 for passenger side configuration.

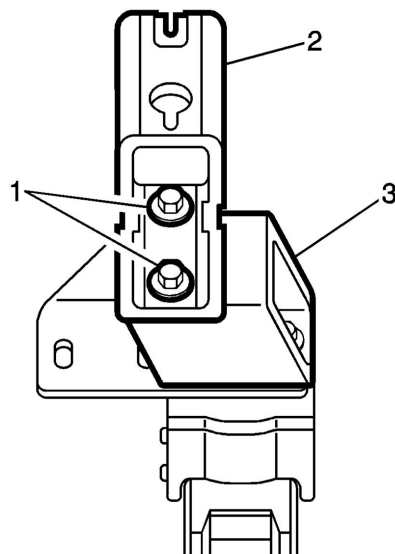

- Using a 13mm socket, assemble frame mount (2) onto lateral mount (3) with M8 washered hex bolts (1).

Tighten

Tighten the M8 washered hex bolts (1) to 22 Y (16 lb ft).

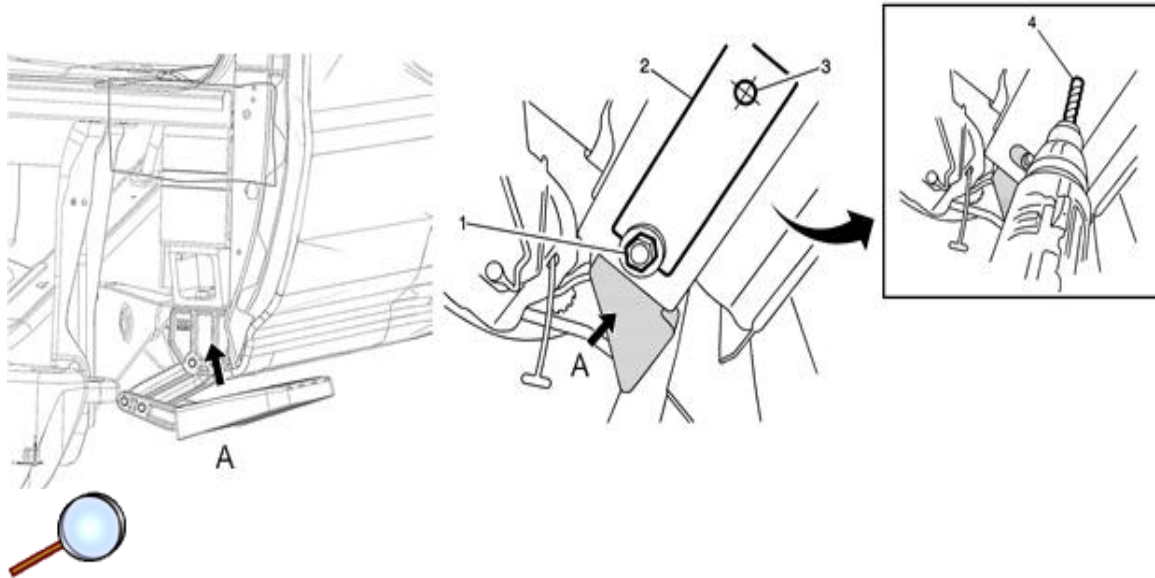

Caution: Always check scale, size and position of all templates before drilling. Failing to do so may cause damage to the vehicle, misalignment of components or the inability to install the accessory.

4. Locate the M8 bolt (1) from forward most bed channel on the underside of the truck. Using a 13mm socket, remove existing M8 bolt and replace with longer M8 (bolt included in kit). Loosely tighten bolt to a gap of about 12mm (1/2"). Slide slotted end of the drill template (2) over bolt and hold template in place with tape. Center punch hole (3) and pre-drill using an 1/8" drill bit (4). Then drill to 17/32". Apply GM Vehicle Care Super Lube to drilled surface.

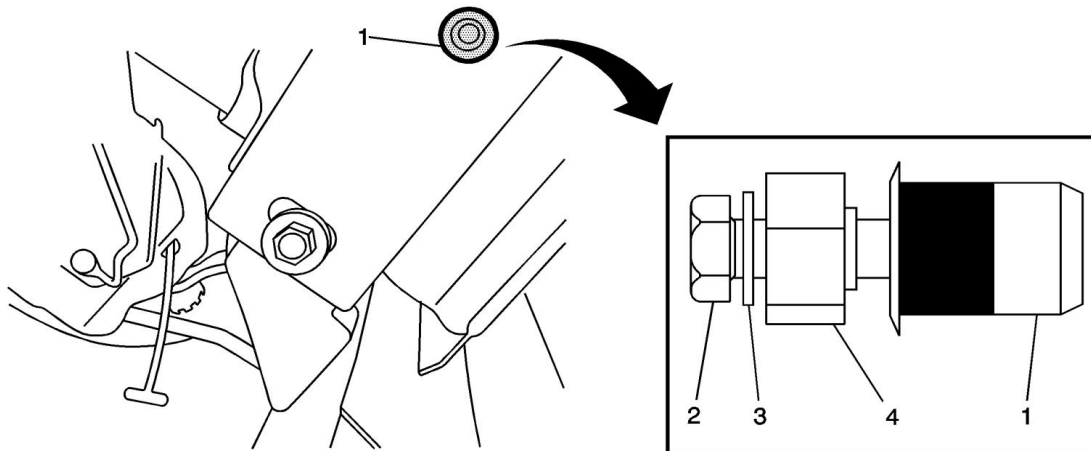

5. Install rivet nut (1) onto bed channel. With rivet nut tool (4) held in place with 15mm wrench, tighten hex bolt (2) until rivet nut (1) deforms and secures itself to the sheet metal.
Tighten
Tighten the hex bolt to 27 Y (20 lb ft).
Remove hex bolt and rivet nut tool.
Install M8 washered hex bolt (2), (3) into rivet nut (1), leaving a gap of about 12mm (1/2").

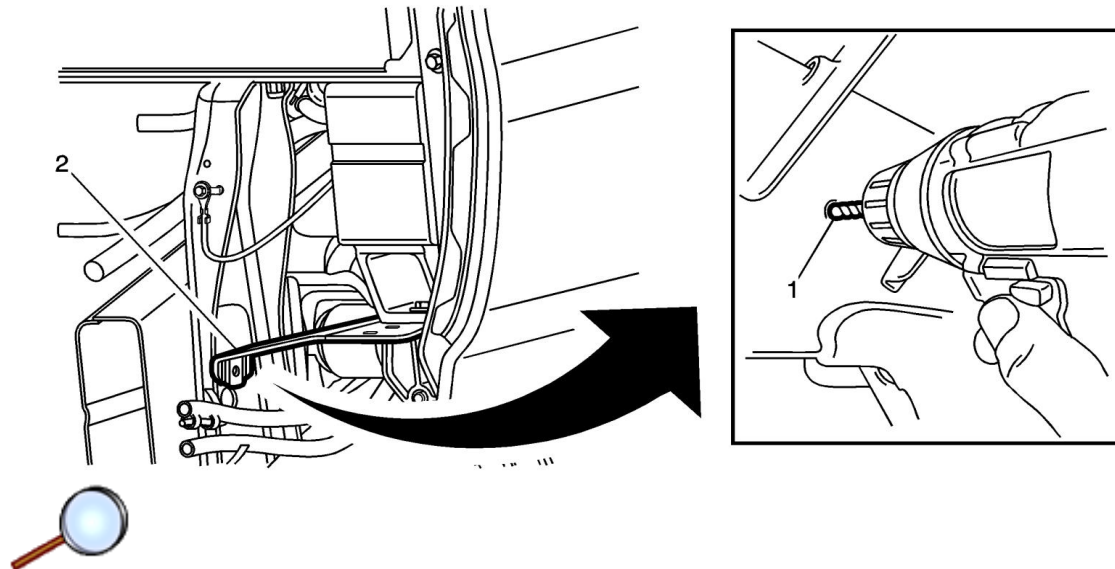

6. Lift bedside assist step assembly into position, hooking upper mount onto installed bed channel bolts from Step 5. Snug bolts and slide frame bracket (2) up to frame and mark hole location. Remove step assembly, center punch (1) and pre-drill using a 1/8" drill bit. Then drill to 17/32". Apply GM Vehicle Care Super Lube to drilled surface.

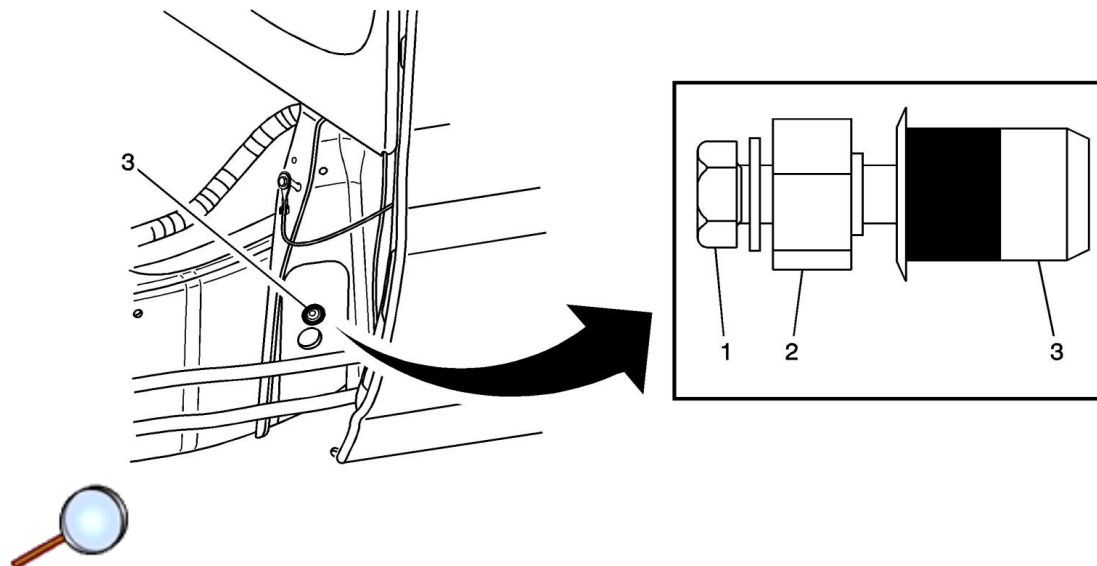

7. Install rivet nut (3) onto frame rail just behind truck bed frame mount, just forward of rear wheel well. With rivet nut tool (2) held in place with 15mm wrench, tighten hex bolt (1) until rivet nut (3) deforms and secures itself to the sheet metal.
Tighten
Tighten the hex bolt to 27 Y (20 lb ft).

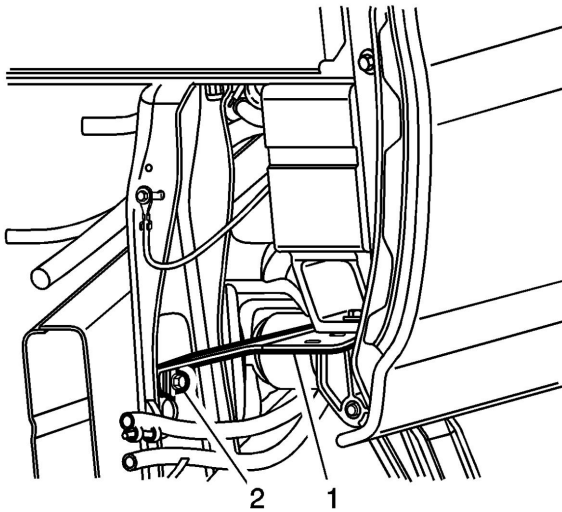

8. Lift bedside assist step assembly into position, hooking upper mount onto installed bed channel bolts from Step 5. Install additional M8 washered hex bolt (2) through frame bracket (1) and into rivet nut installed on frame rail. Straighten assembly. Tighten
Tighten the M8 washered hex bolts (2) to 22 Y (16 lb ft).

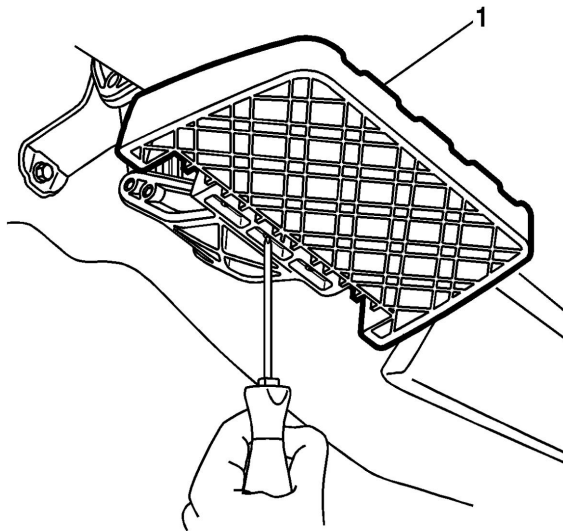

9. Place step pad (1) on linkage mounting interface. Mounting interface allows three positions, centered and offset to either side. Mount as necessary for clearances on truck configuration (ie. shift back to clear accessory running board). Using a T25 torx bit, tighten all three screws. Tighten
Tighten all three screws to 7 Y (5 lb ft).

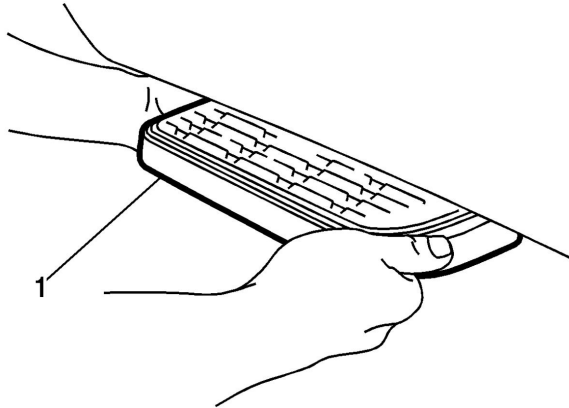

10. Adjust step pad (1) to be in line with fender.

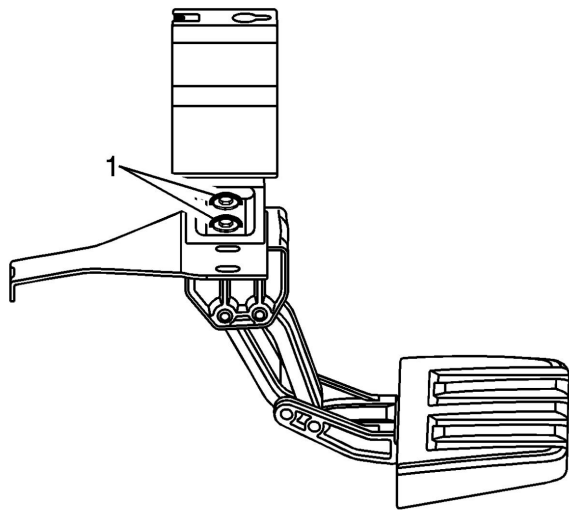

11. Tighten the M10 hex bolts (1) using a 15mm socket.
Tighten
Tighten the M10 hex bolts (1) to 27 Y (20 lb ft).