

Front Grille Package Installation (Chevrolet Instruction P/N 23156437)

[Installation Instructions Part Number](#)

23156437

Kit Contents

| Qty | Description |
|-----|---------------------------|
| 1 | Upper Grille |
| 1 | Grille Seal |
| 1 | Installation Instructions |

[Procedure](#)

Remove Front Compartment Sight Shield

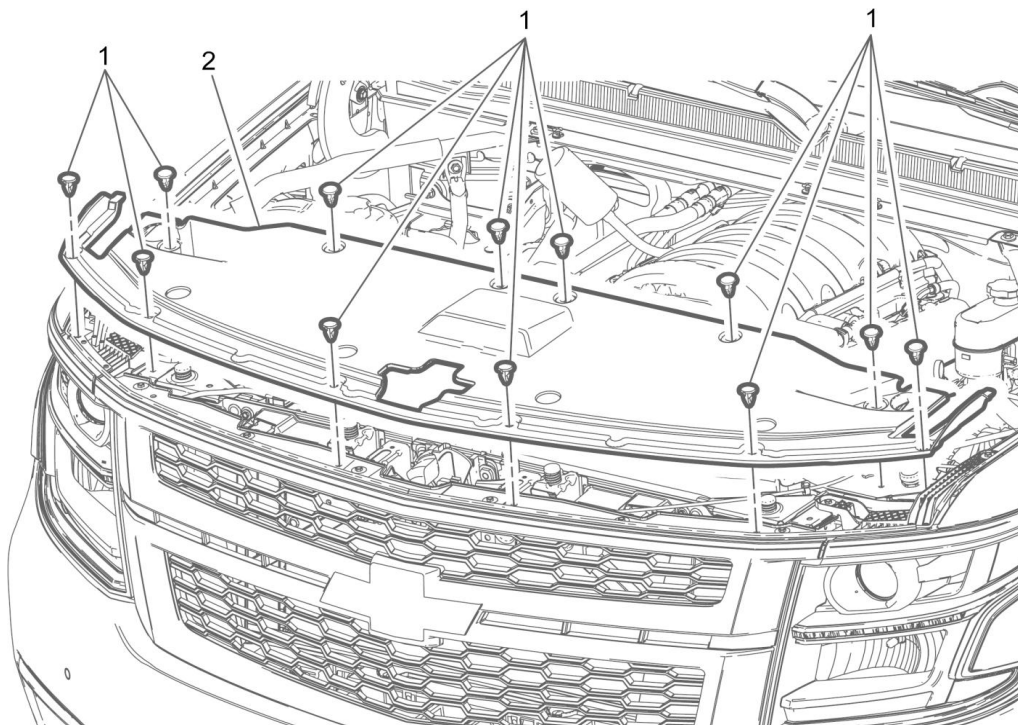

1. Remove and retain the front compartment front sight shield push-in retainers (1).
2. Remove the front compartment front sight shield (2).

Remove Left and Right Front Wheel Opening Rear Molding

© 2014 General Motors. All rights reserved.

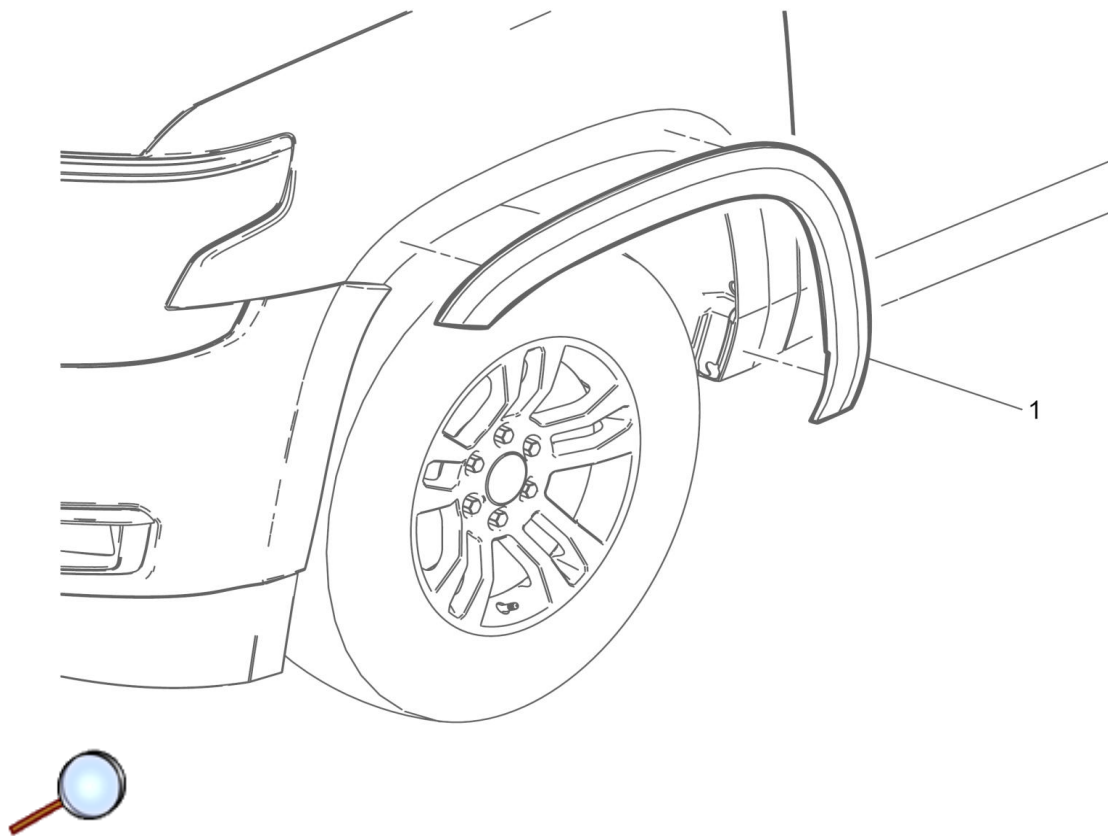

Caution: Use a plastic, flat-bladed tool to prevent paint damage when removing the front wheel opening rear molding.

1. Use a heat gun or equivalent to remove the front wheel opening rear molding. Use a plastic flat bladed tool to assist in removal.
2. Clean any remaining residue with a 50/50 mixture by volume of isopropyl alcohol and clean drinkable water. Wipe surface dry with a clean lint-free towel.
3. Upon reassembly the part and surface should be 21°C (70°F) prior to installation. The vehicle should remain 21°C (70°F) for one hour after assembly to allow adhesive to develop sufficient bond strength.
4. Upon reassembly apply adhesive tape to the left and right front wheel opening rear moldings, while removing the protective liners from the adhesive tape, be careful not to touch tape with hands and do not allow tape to come in contact with dirt or any foreign matter prior to adhesion.

Upon reassembly, using the palm of the hand and apply even pressure from end to end to ensure full adhesion is made.

Remove Left Front Wheelhouse Liner

1. Remove left front wheel and tire assembly. Refer to Vehicle Service Manual.

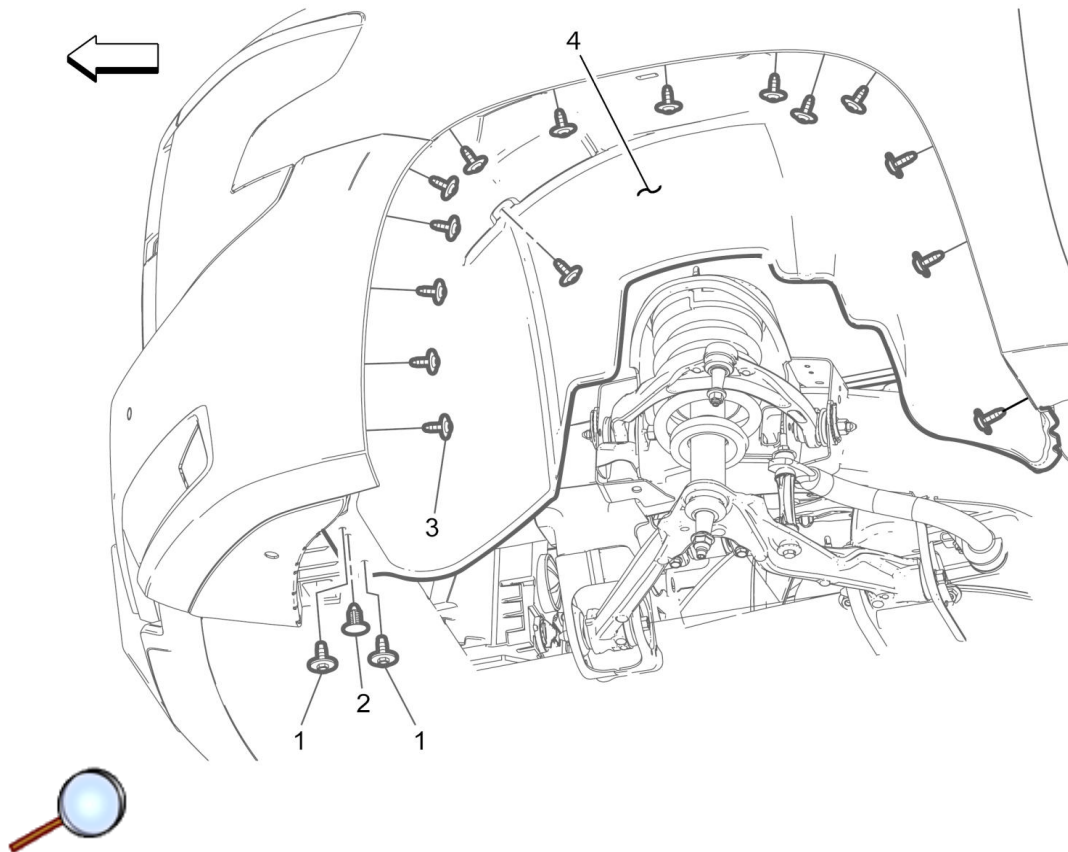

Caution: Use the correct fastener in the correct location. Replacement fasteners must be the correct part number for that application. Fasteners requiring replacement or fasteners requiring the use of thread locking compound or sealant are identified in the service procedure. Do not use paints, lubricants, or corrosion inhibitors on fasteners or fastener joint surfaces unless specified. These coatings affect fastener torque and joint clamping force and may damage the fastener. Use the correct tightening sequence and specifications when installing fasteners in order to avoid damage to parts and systems.

2. Remove and retain the left front wheelhouse liner bolts (1).
Upon reassembly, tighten the left front wheelhouse bolts to 7 N.m (62 lb in).
3. Remove and retain the left front wheelhouse plastic retainer (2).
4. Remove and retain the left front wheelhouse liner fasteners (3)
Upon reassembly, tighten the left front wheelhouse fasteners to 2.5 N.m (22 lb in).
5. Remove the left front wheelhouse liner (4).

Note: Disconnect any electrical harnesses/connectors and attached parts from the left side front wheelhouse liner as needed.

Remove Right Front Wheelhouse Liner

1. Remove right front wheel and tire assembly. Refer to Vehicle Service Manual.

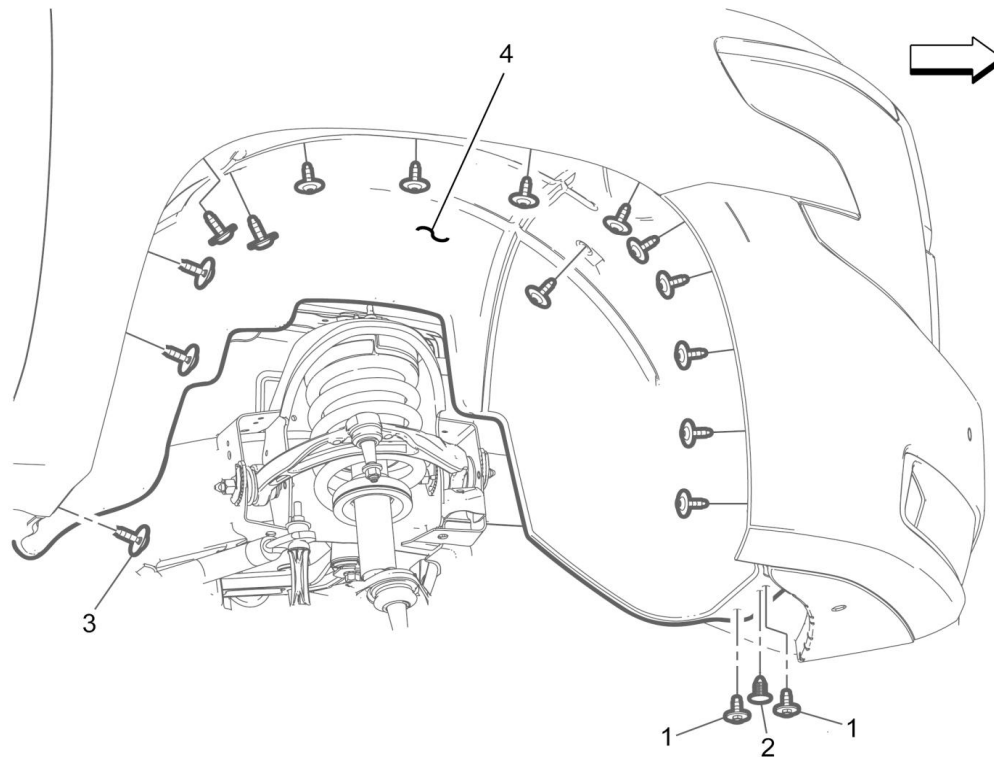

2. Remove and retain the right front wheelhouse liner bolts (1).
Upon reassembly, tighten the right front wheelhouse bolts to 7 N.m (62 lb in).
3. Remove and retain the right front wheelhouse plastic retainer (2).
4. Remove and retain the right front wheelhouse liner fasteners (3)
Upon reassembly, tighten the right front wheelhouse fasteners to 2.5 N.m (22 lb in).
5. Remove the right front wheelhouse liner (4).

Note: Disconnect any electrical harnesses/connectors and attached parts from the right side front wheelhouse liner as needed.

Remove Front Bumper Fascia

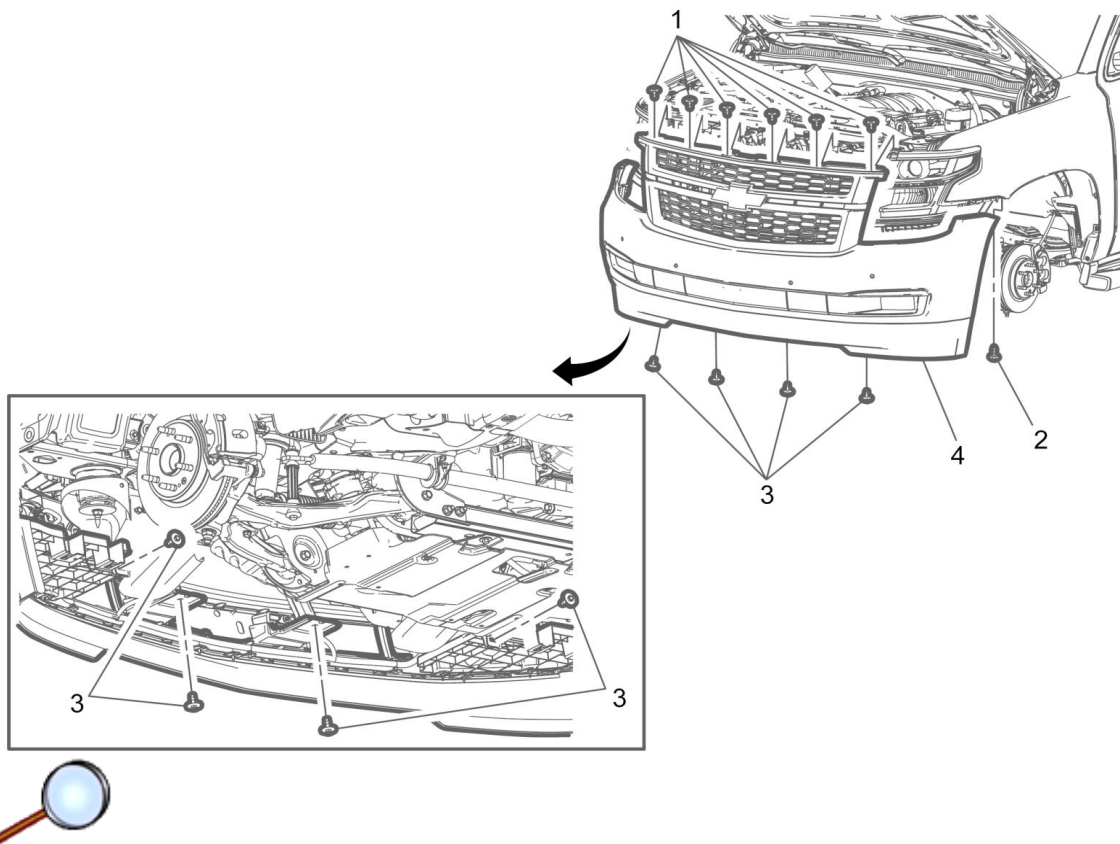

1. Remove and retain the front radiator grille bolts (1).
Upon reassembly, tighten the front bumper fascia lower bolts to 7 N.m (62 lb in).
2. Remove and retain the front bumper fascia guide bolts (2).
Upon reassembly, tighten the front bumper fascia center support bolts to 2.5 N.m (22 lb in).
3. Remove and retain the front bumper fascia lower bolts (3).
Upon reassembly, tighten the front bumper fascia lower bolts to 7 N.m (62 lb in).
4. Carefully push a small nylon wedge between the fascia and the front fascia guide. Insert a small flat-bladed tool into the fascia slot and depress the snaps one at a time and pull on the fascia at the same time to gradually remove the fascia (4) from the front fascia guide.
5. Disconnect the electrical connectors before attempting removal of the front bumper fascia.

Remove OEM Grille

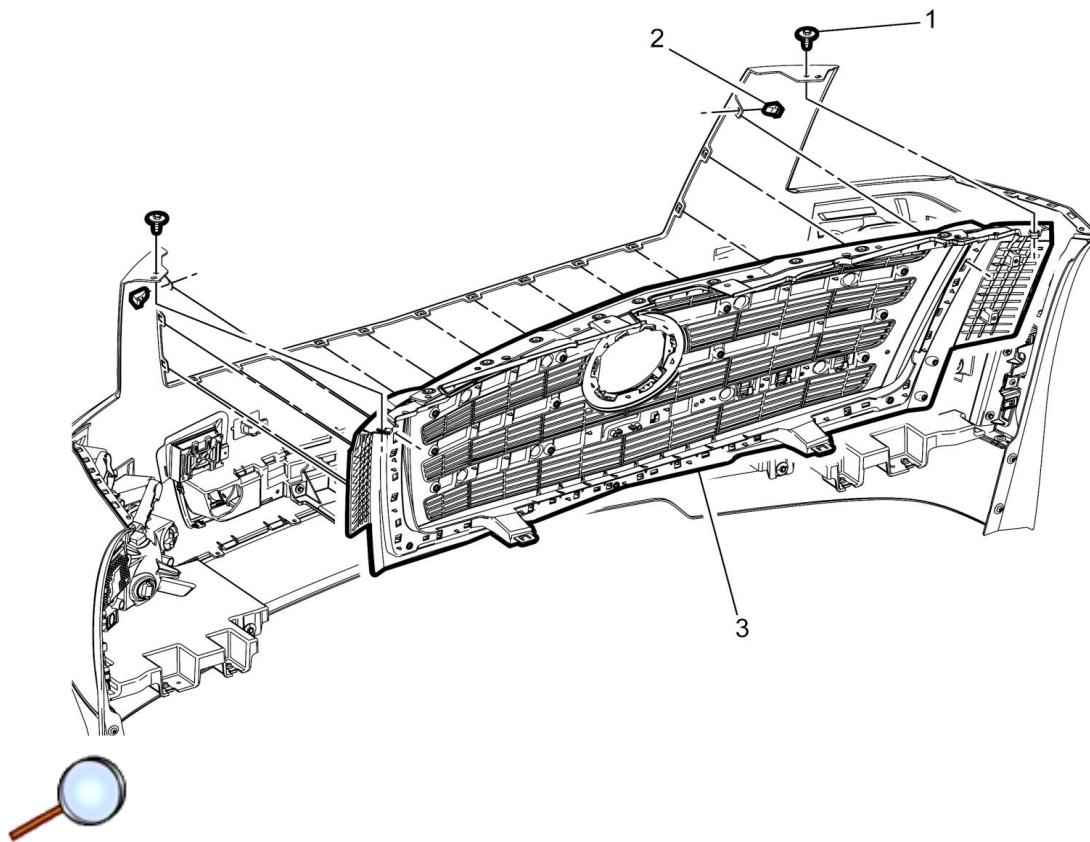

1. Remove and retain the front upper grille bolts (1).
2. Remove and retain the front upper grille retainers (2).
3. With a suitable flat bladed tool release the 14 locking tabs and pull the front upper grille from the front bumper fascia.

Install Accessory Grille

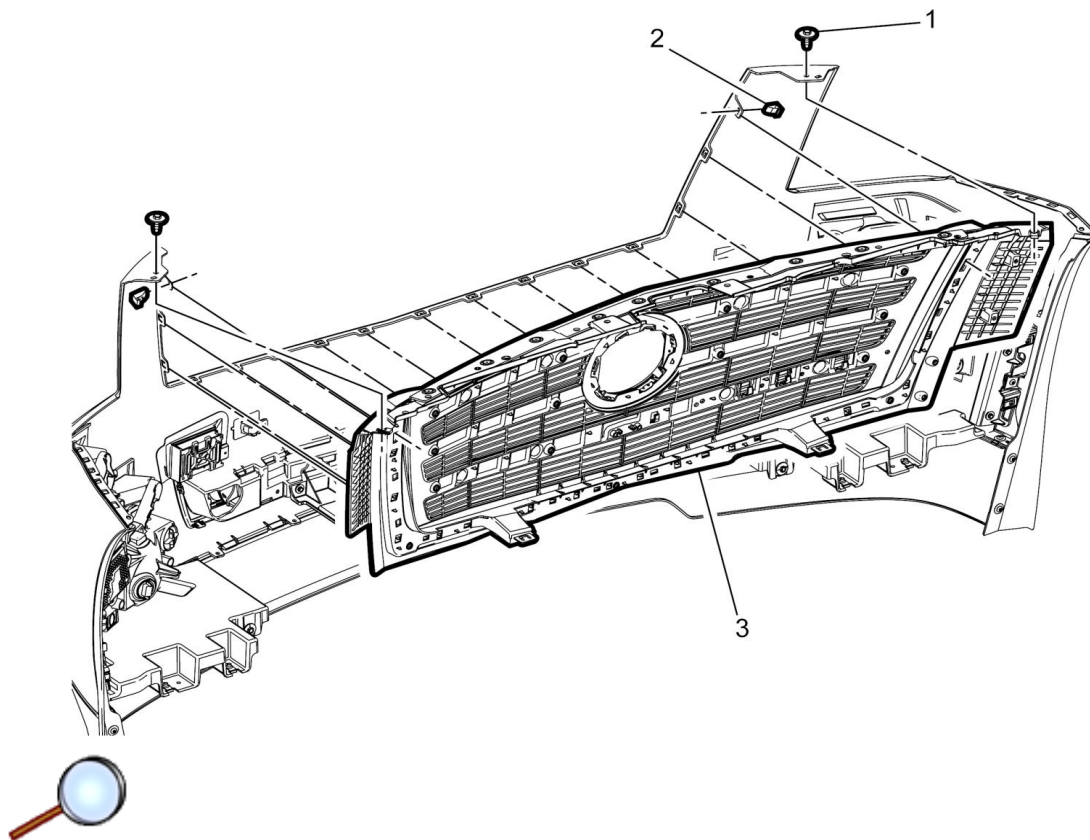

1. Position the front upper Accessory grille (3) to the front bumper fascia engaging the 14 locking tabs.
2. Install the previously retained front upper grille retainers (2).
3. Install the previously retained front upper grille bolts (1).
Tighten
Tighten the bolts to 7 N.m (62 lb in).
4. Install all previously removed components.

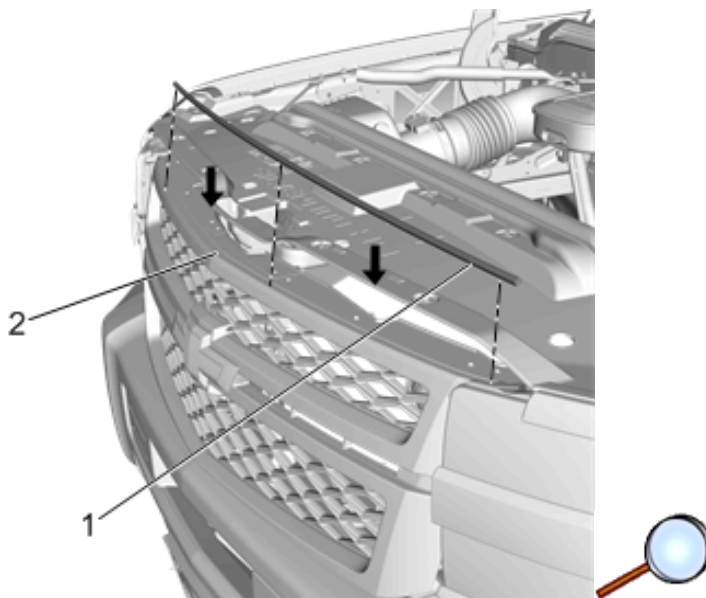

5. Install grille seal (1) to the upper groove (2) on top of the accessory grille.