

# Front and Rear Suspension Modification Kit Installation

Installation Instruction Part Number

23158166

23158167

Tools Required

CH49375 Strut Rod Nut Socket

For equivalent regional tools, refer to Vehicle Service Manual.

## [Front Strut Removal Procedure](#)

1. Remove the air inlet grille panel. Refer to Vehicle Service Manual.
2. Raise and support the vehicle. Refer to Vehicle Service Manual.
3. Remove the front tire and wheel assembly. Refer to Vehicle Service Manual.
4. Remove the stabilizer shaft link from the front strut assembly. Refer to Vehicle Service Manual.

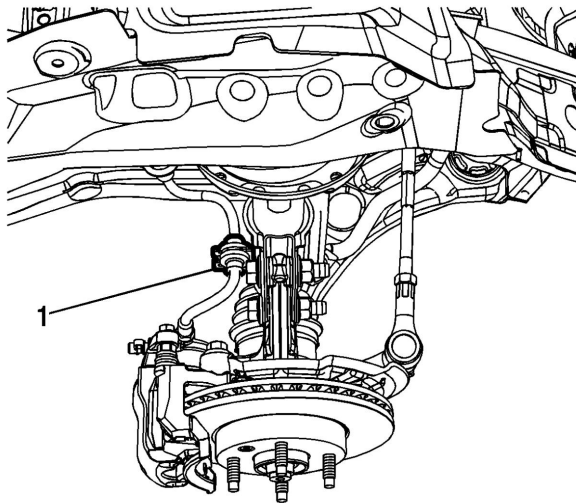

5. Remove the front brake hose (1) from the front strut assembly.
6. Remove the speed sensor wiring harness from the front strut assembly, if needed.
7. Remove the outer tie rod end from the steering knuckle. Refer to Vehicle Service Manual.
8. Support the lower control arm with a jack stand.

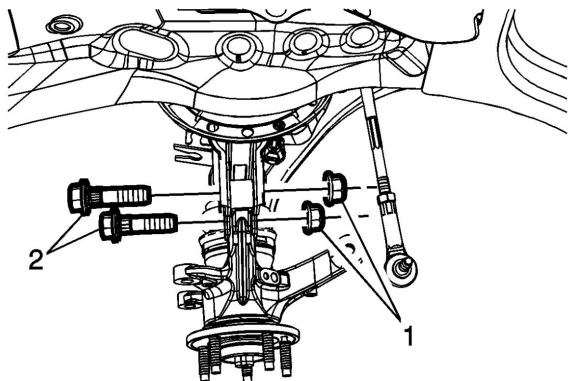

9. Remove the front strut nut (1) and the bolt (2) from the front strut.

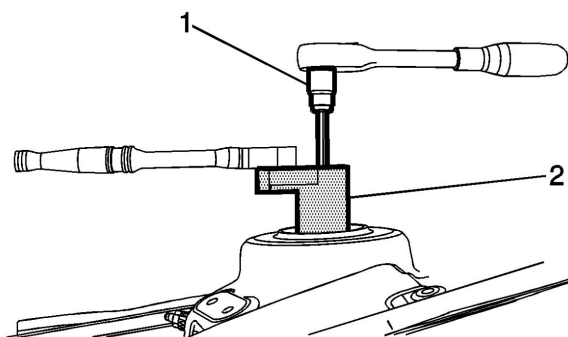

10. Using the CH49375 socket (2) and the proper size Torx® wrench, loosen the front strut nut.

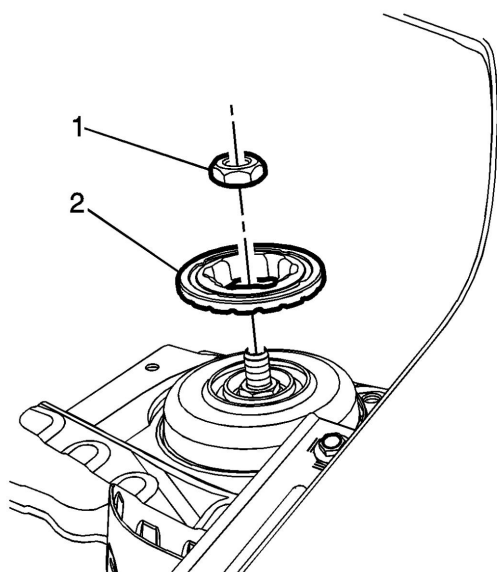

© 2014 General Motors. All rights reserved.

11. Remove the front strut nut (1) and the retaining plate (2).

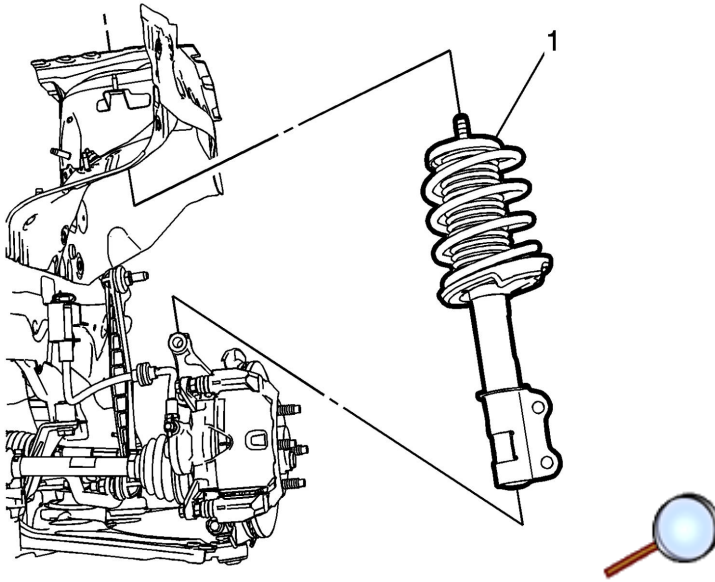

12. Remove the front strut assembly from the vehicle (1).

### [Front Strut Disassembly Procedure](#)

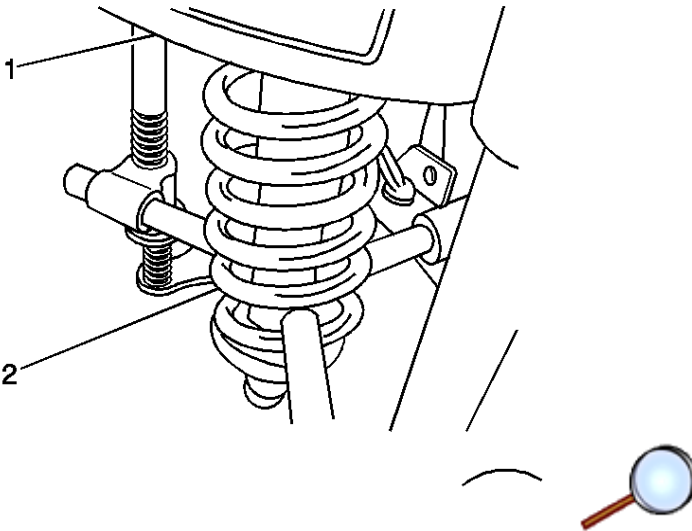

**Note:** The spring is compressed when the strut moves freely.

1. Install the strut assembly (2) in a suitable spring compressor (1) and compress the front spring.

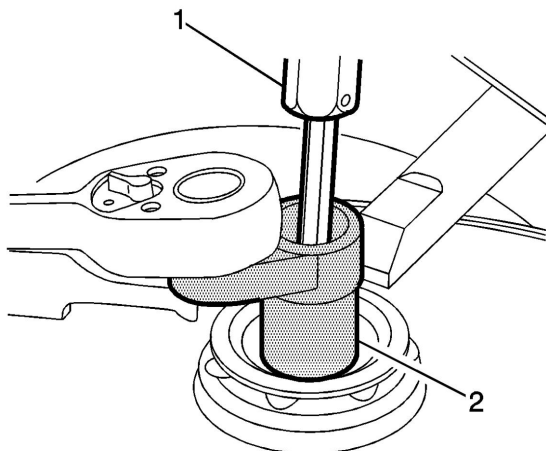

2. Use a suitable bit (1) and socket (2) to loosen the front suspension strut mount nut.

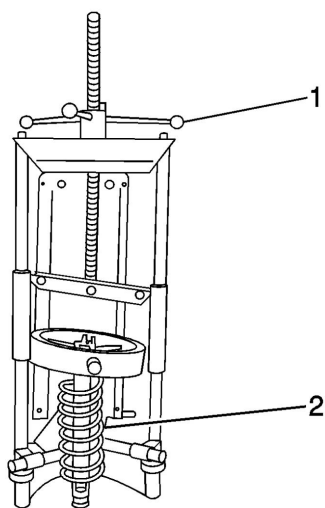

3. Slowly loosen the spring compressor (2) to remove the front suspension strut components to be serviced.

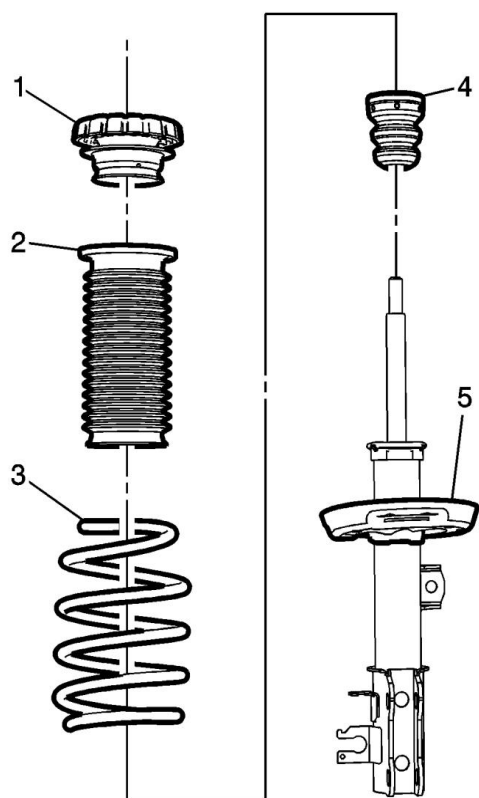

4. Remove the front suspension strut mount assembly (1), front spring insulator (2), front spring (3), front suspension strut bumper (4) and the front strut (5) from the spring compressor.

#### [Front Strut Assembly Procedure](#)

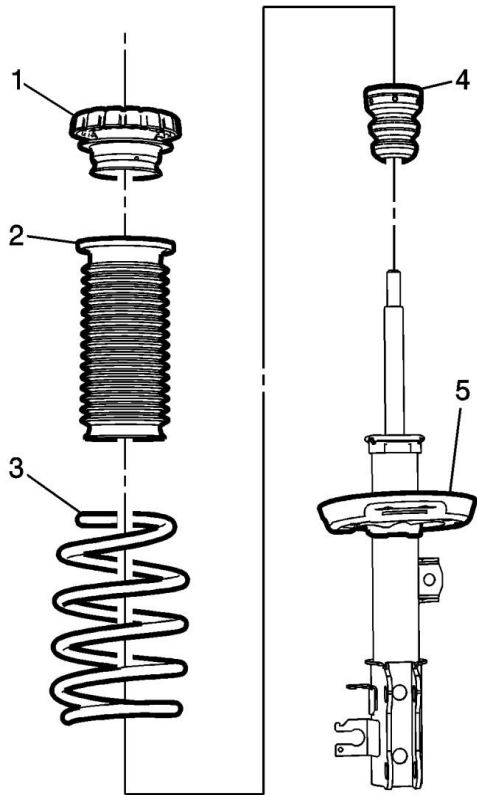

1. Install the front suspension strut (5), front suspension strut bumper (4), front spring (3), front spring insulator (2) and the front suspension strut mount assembly (1) in the spring compressor.

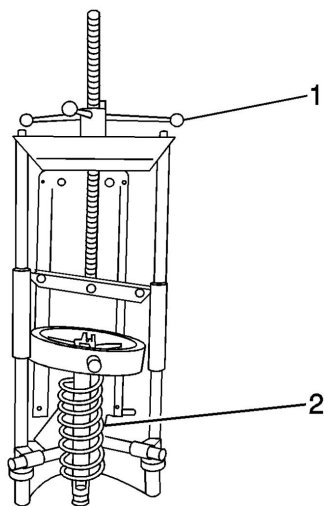

2. Use the spring compressor (1) to compress the front spring (2).
3. Install the front suspension strut mount nut and tighten as much as possible by hand.

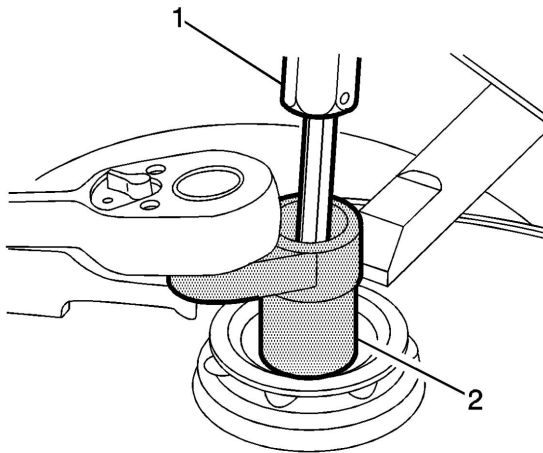

**Caution:** Use the correct fastener in the correct location. Replacement fasteners must be the correct part number for that application. Fasteners requiring replacement or fasteners requiring the use of thread locking compound or sealant are identified in the service procedure. Do not use paints, lubricants, or corrosion inhibitors on fasteners or fastener joint surfaces unless specified. These coatings affect fastener torque and joint clamping force and may damage the fastener. Use the correct tightening sequence and specifications when installing fasteners in order to avoid damage to parts and systems.

4. Use a suitable bit (1) and socket (2) to tighten the front suspension strut mount nut to **4** lb ft . Y
5. Remove the strut assembly from the spring compressor.

### [Front Strut Installation Procedure](#)

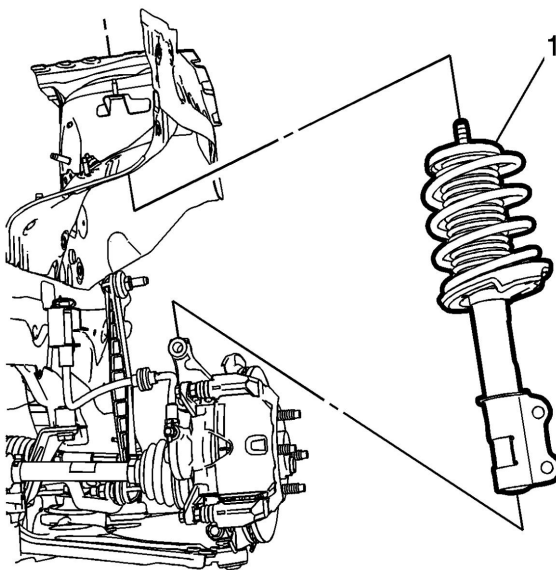

1. Position the front strut assembly (1) in the vehicle.

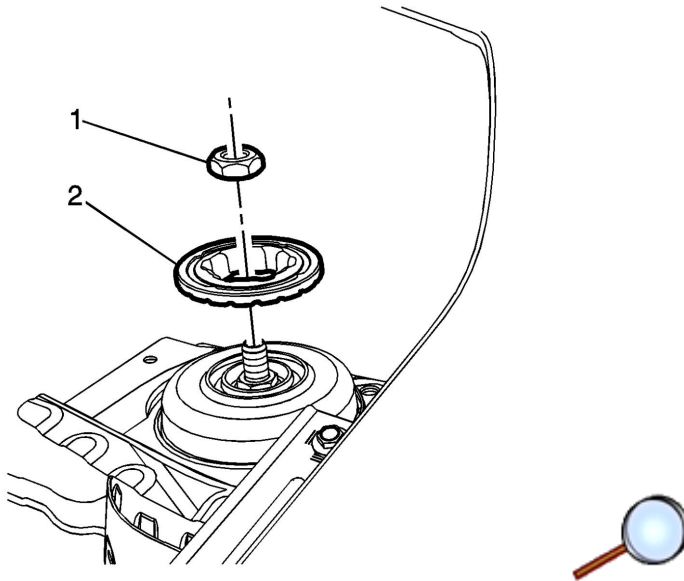

2. Install the front strut nut (1) and the retaining plate (2).

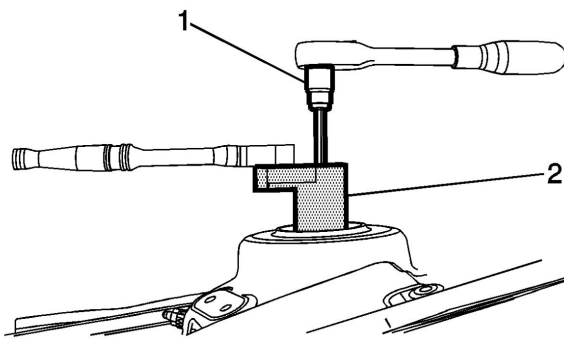

3. Using the CH 49375 socket (2) and the proper size Torx® wrench to hold the strut shaft, tighten the nut to **Y 4** lb ft .



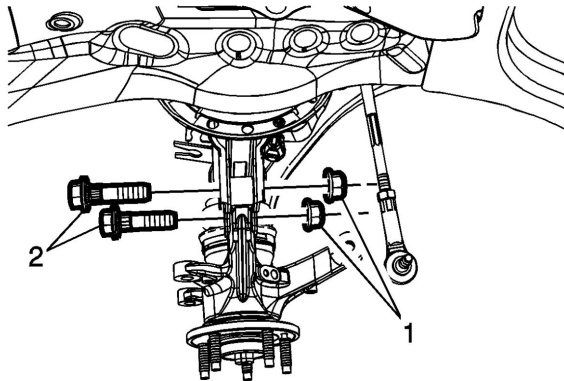

4. Install the front strut nut (1) and the bolt (2) from the front strut and tighten the nut to 11 Y lb ft .
5. Install the stabilizer shaft link in the front strut assembly. Refer to Refer to Vehicle Service Manual.
6. Remove the jack stand from the lower control arm.
7. Install the outer tie rod end in the steering knuckle. Refer to Refer to Vehicle Service Manual.
8. Install the speed sensor wiring harness on the front strut assembly, if needed.

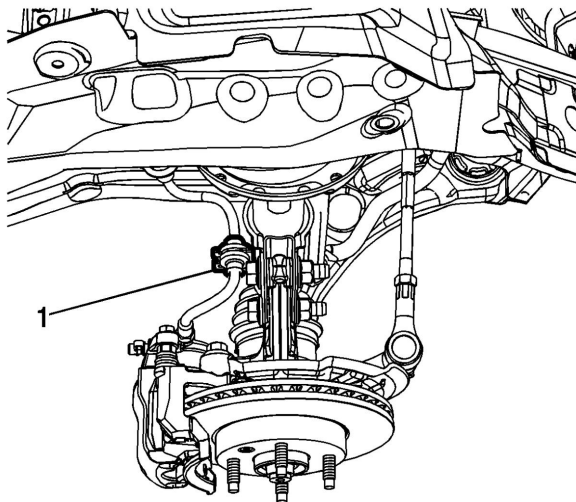

9. Install the front brake hose (1) on the front strut assembly.
10. Install the front tire and wheel assembly. Refer to Refer to Vehicle Service Manual.
11. Remove the support and lower the vehicle.
12. Install the air inlet grille panel. Refer to Refer to Vehicle Service Manual.

[Rear S oc Absorber Removal Procedure](#)

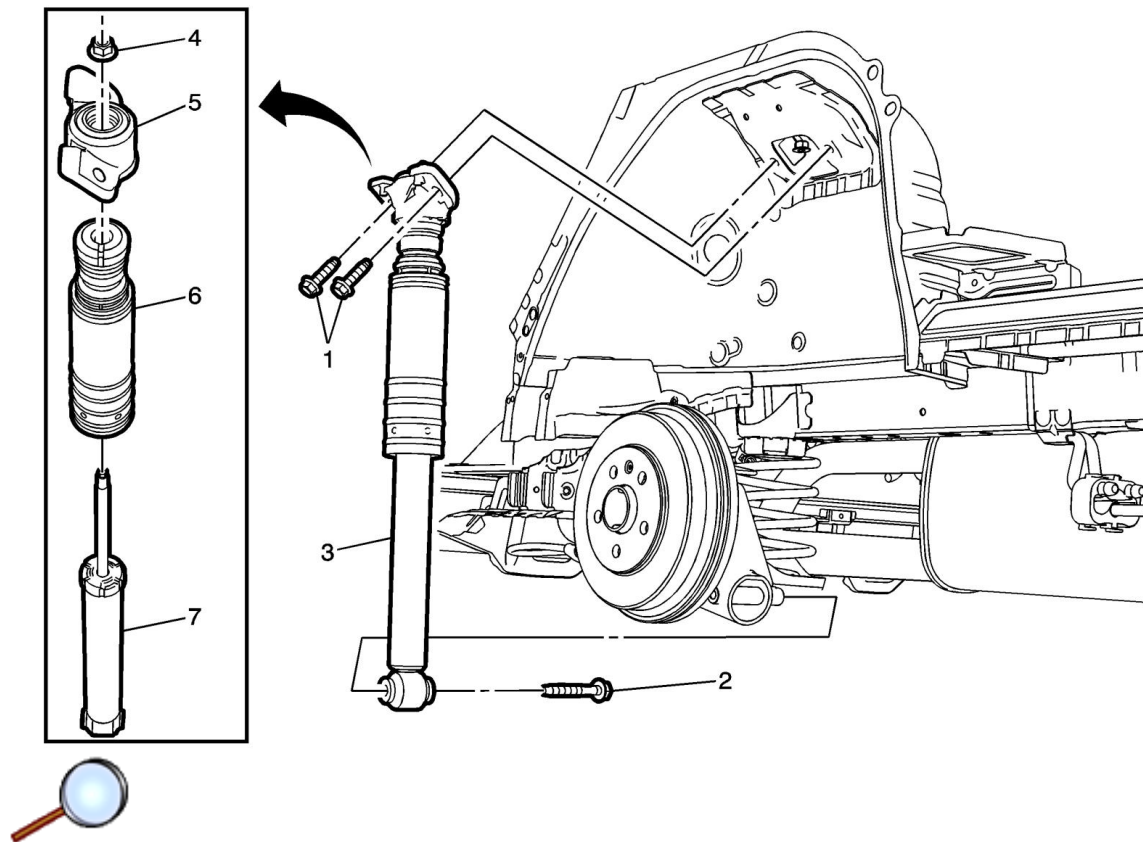

1. Raise and support the vehicle. Refer to Vehicle Service Manual.
2. Remove the rear tire and wheel assembly. Refer to Vehicle Service Manual.
3. Support the rear axle with a hydraulic jack.
4. Remove the rear shock absorber upper bolts (1).
5. Remove the rear shock absorber lower bolt (2).
6. Remove the rear shock absorber assembly (3) from the vehicle.

#### Rear Shock Absorber Disassembly Procedure

- 6.1. Remove shock absorber nut (4) from shock (7).
- 6.2. Remove shock absorber mount (5).
- 6.3. Remove shock absorber bumper (6).

[Rear Spring Insulator and Lower Control Arm Removal and Installation Procedure](#)

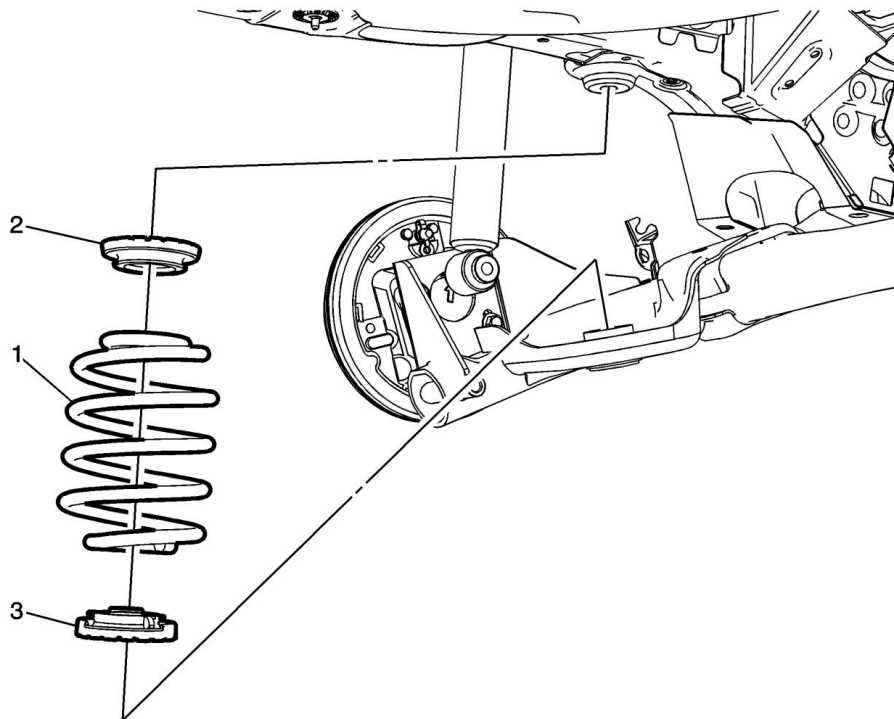

**Note:** Note the position of the rear spring in relationship to the insulators.

1. Lower the rear axle and remove the rear spring (1) from the upper (2) and lower (3) rear spring insulators.
2. Ensure that the lower rear spring insulator (3) is properly seated in the rear axle.
3. Ensure that the upper rear spring insulator (2) is properly seated in the rear frame rail.
4. Install the rear spring (1) to the upper and lower rear spring insulators.

[Rear Shock Absorber Assembly Procedure](#)

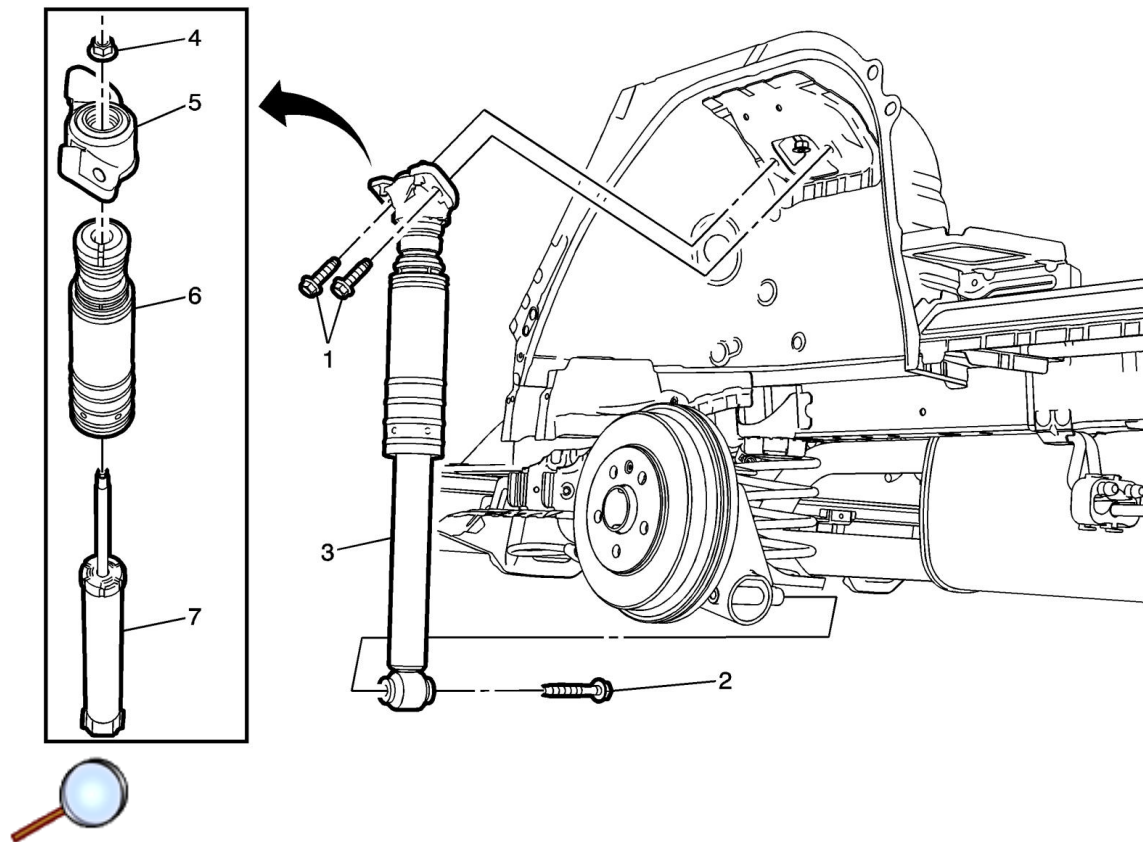

1. Install shock absorber bumper (6) to the rear shock absorber (7).
2. Install the shock absorber mount (5).
3. Install the shock absorber nut (4) and tighten the nut to **Y 1** lb ft .

#### Rear Shock Absorber Installation Procedure

- 3.1. Install the rear shock absorber assembly (3) to the vehicle.
- 3.2. Install the rear shock absorber lower bolt (2).
  - Ti ten
  - First Pass: **1 Y** 74 lb ft .Ti ten
  - Second Pass: plus de rees.
4. Install the rear shock absorber upper bolts (1) and tighten the bolts to **Y 43** lb ft .
5. Install the rear tire and wheel assembly. Refer to Vehicle Service Manual.
6. Remove support and lower the vehicle.