

Front Fender Mud Flap Package Installation

Kit Contents

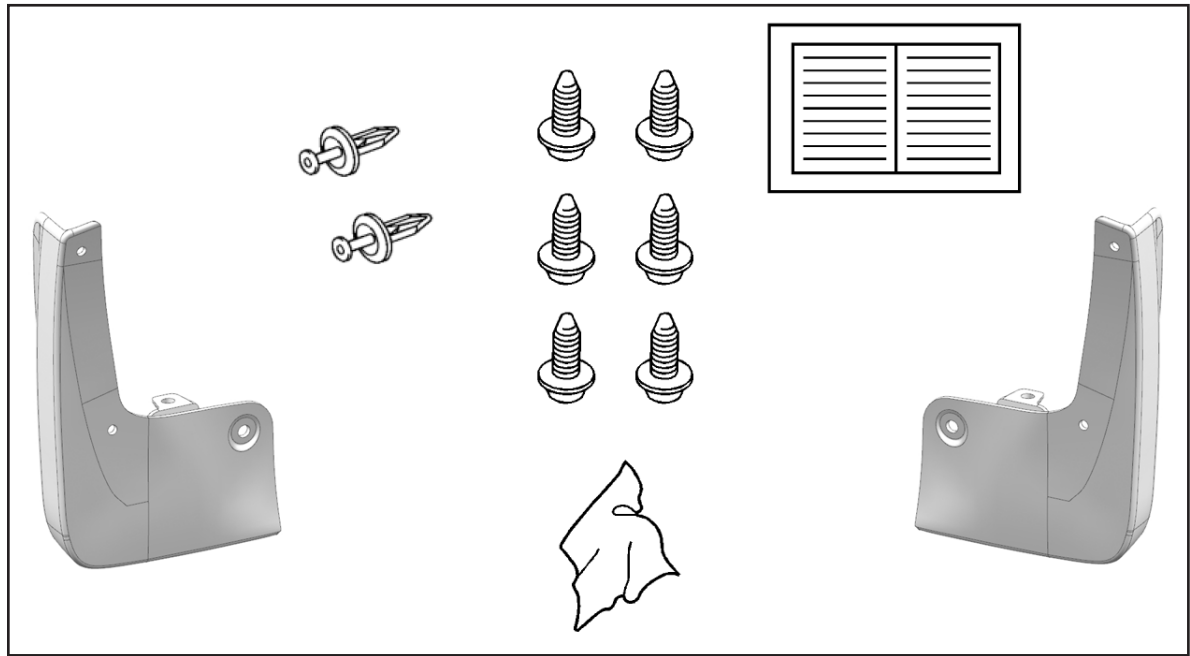

Tools Required

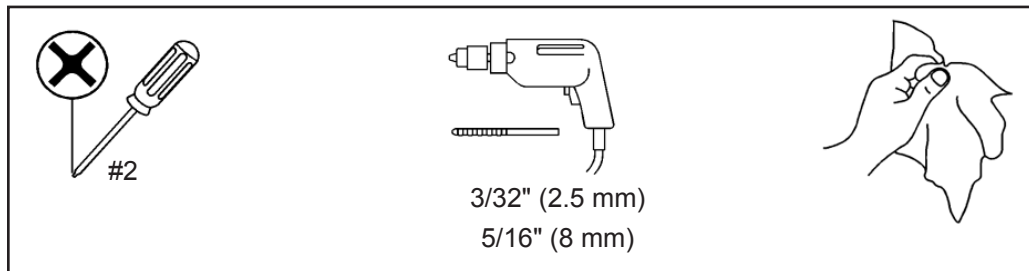

Procedure

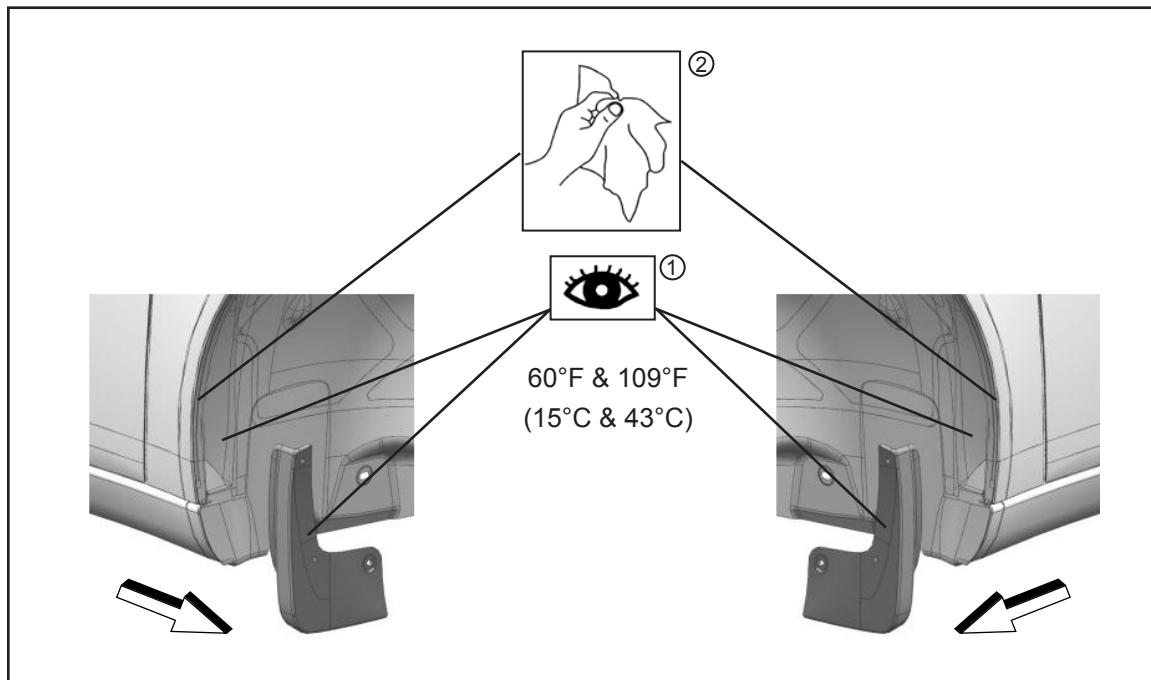

Accessory FRONT Mud Guard

IR 11MR13

PART NO.

23176921

SHEET

1 OF 2

ALL INFORMATION WITHIN ABOVE BORDER TO BE PRINTED EXACTLY AS SHOWN ON 8.5 x 11 WHITE 16 POUND NON-BOND RECYCLABLE PAPER. PRINT ON BOTH SIDES, EXCLUDING TEMPLATES. TO BE UNITIZED IN ACCORDANCE WITH GM SPECIFICATIONS.

DATE	REVISION	AUTH	DR
11MR13	Initial Release - Carlos Martinez	1853047	

TITLE	INSTALLATION INSTRUCTIONS		
Accessory FRONT Mud Guard			
PART NO.	23176921	SHEET	1 OF 2

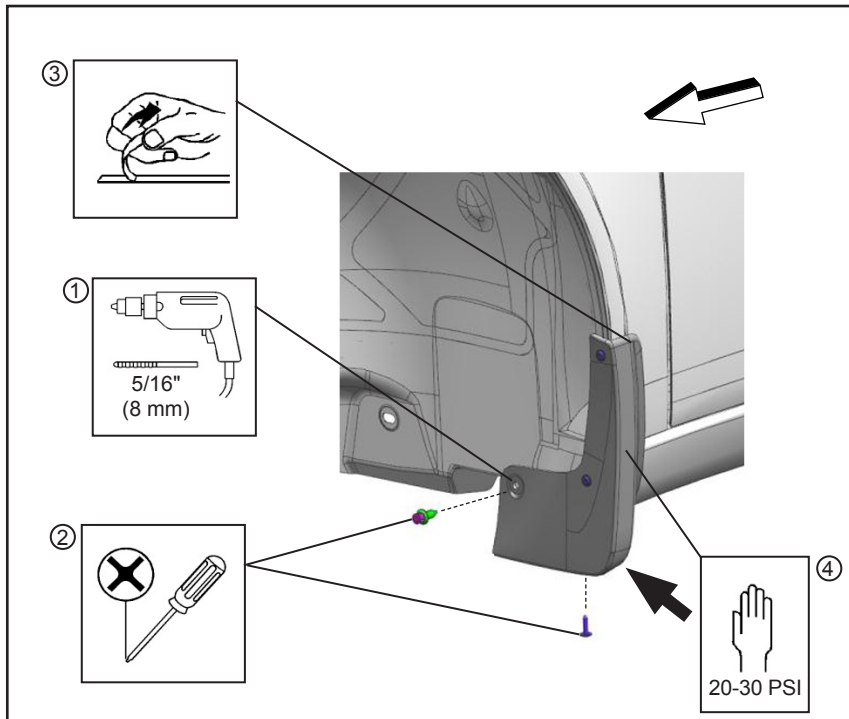
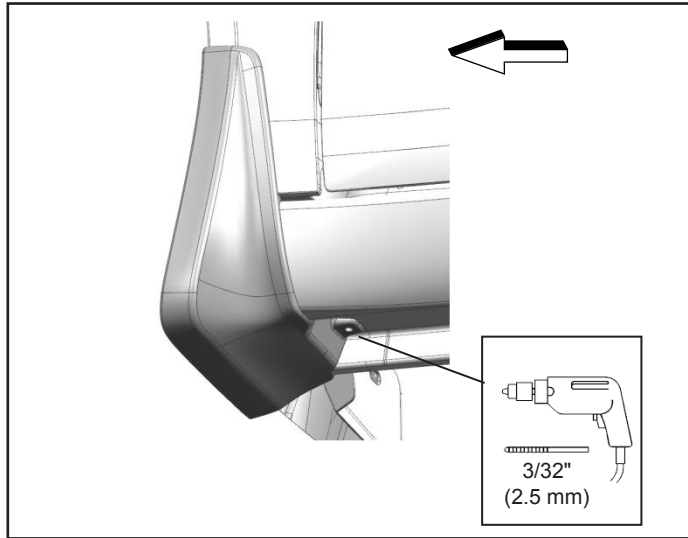
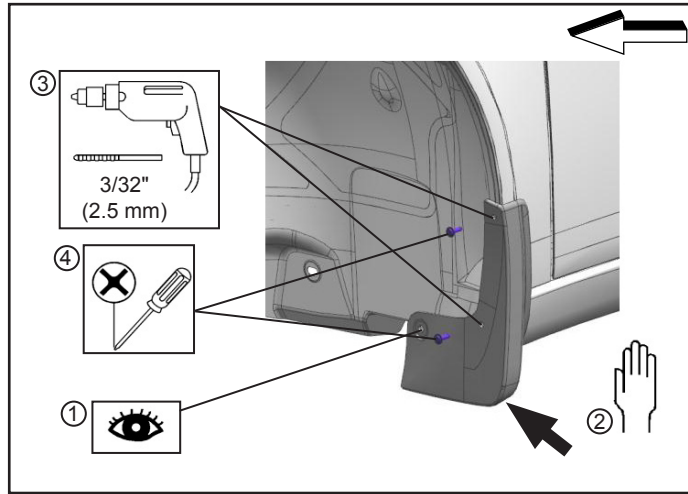

Accessory FRONT Mud Guard

IR 11MR13

PART NO.

23176921

SHEET

2 OF 2

ALL INFORMATION WITHIN ABOVE BORDER TO BE PRINTED EXACTLY AS SHOWN ON 8.5 x 11 WHITE 16 POUND NON-BOND RECYCLABLE PAPER. PRINT ON BOTH SIDES, EXCLUDING TEMPLATES. TO BE UNITIZED IN ACCORDANCE WITH GM SPECIFICATIONS.

DATE	REVISION	AUTH	DR

TITLE	INSTALLATION INSTRUCTIONS		
Accessory FRONT Mud Guard			
PART NO.	23176921		SHEET
		2	OF 2