

# Trailer Hitch Platform Package Installation

## Installation Instructions Part Number

23216646

## Hitch Capacity

**Trailer Weight Rating:** 1000 lb. (Specific to this vehicle)

**Tongue Weight:** 10-15% of trailer weight up to 500lb..

Use as weight carrying only.

**Warning:** Although this hitch is designed to safely tow its rated load, we recommend that you consult your vehicle owner's manual for possible manufacturer's recommendations or limitation. Be sure your trailer has safety chains and that each chain will hold the trailer's maximum gross weight.

## Kit Contents

Qty	Description
1	Platform Assembly – Trailer Hitch
1	Wiring Harness
4	M12 x 1.75 x 35 Bolts
2	Reinforcement Plates
1	Installation Instructions

## Tools Required

Torque wrench

9/32, 7mm, 10mm, 15mm and 18mm sockets

T15 and T20 driver

## [Procedure](#)

© 2018 General Motors. All rights reserved.

## For Platinum Vehicles

1. The customer needs to also order The production part 84060646 PLATE,RR BPR FASCIA LWR SKID. This will replace lower fascia. (84124128 COVER ASM, RR BPR FASCIA TRLR HITCH (aka Hitch Cover) is optional at the customers discretion).
2. Removal Process of the Fascia will be same as below.

## For Non Platinum Vehicles

### Warning:

- Wear Safety glasses in order to avoid eye damage.
- In order to avoid being burned, do not service the vehicle while the exhaust system is still hot. Service the vehicle when the exhaust system is cool.

1. Raise and secure the vehicle on hoist.

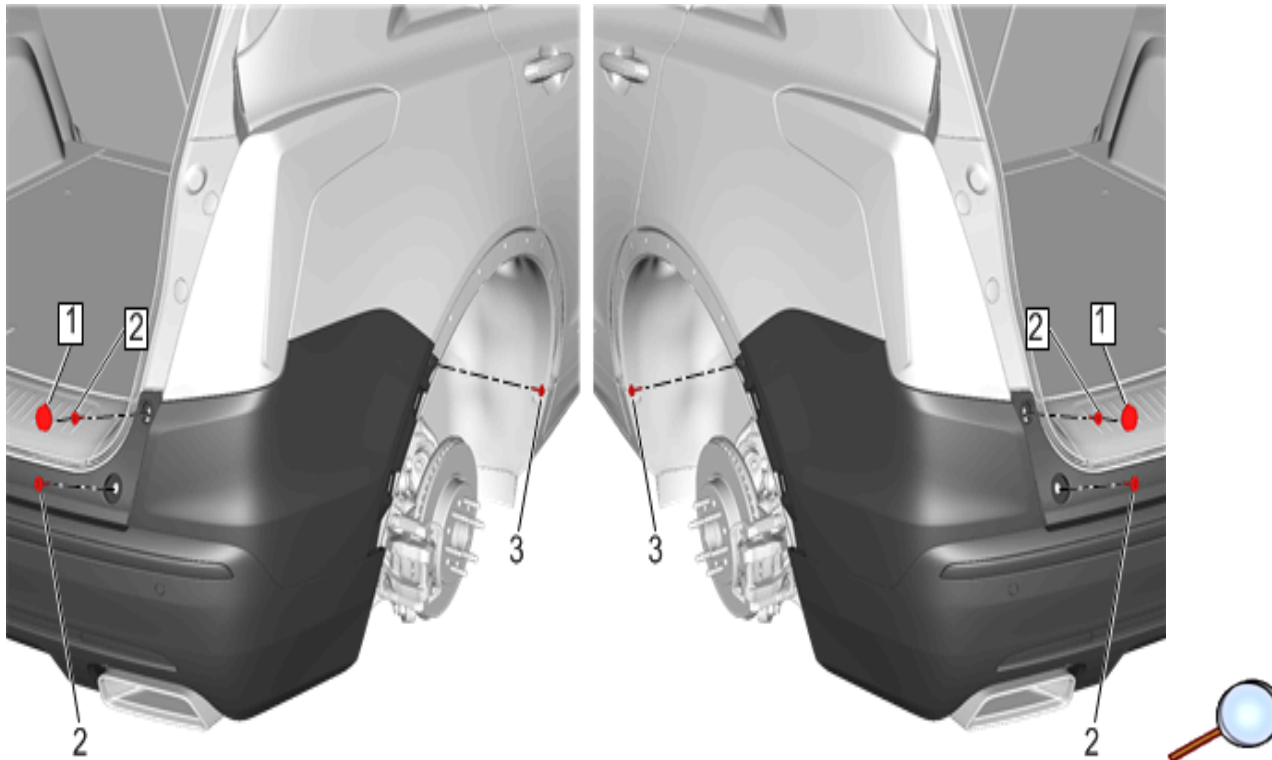

2. Remove the left and right rear wheel opening moldings. Refer to Vehicle Service Manual.

**Caution:** Use the correct fastener in the correct location. Replacement fasteners must be the correct part number for that application. Fasteners requiring replacement or fasteners requiring the use of thread locking compound or sealant are identified in the service procedure. Do not use paints, lubricants, or corrosion inhibitors on fasteners or fastener joint surfaces unless specified. These coatings affect fastener torque and joint clamping force and may damage the fastener.

Use the correct tightening sequence and specifications when installing fasteners in order to avoid damage to parts and systems.

3. Remove the screws (3) securing the rear wheelhouse liner to rear fascia. Upon reassembly tighten the screws to  $2.5 \pm 0.5$  Nm.
4. Remove the screw covers (1) from the rear fascia.
5. Remove the screws (2) from the rear upper fascia. Upon reassembly tighten the screws to  $2.5 \pm 0.5$  Nm.

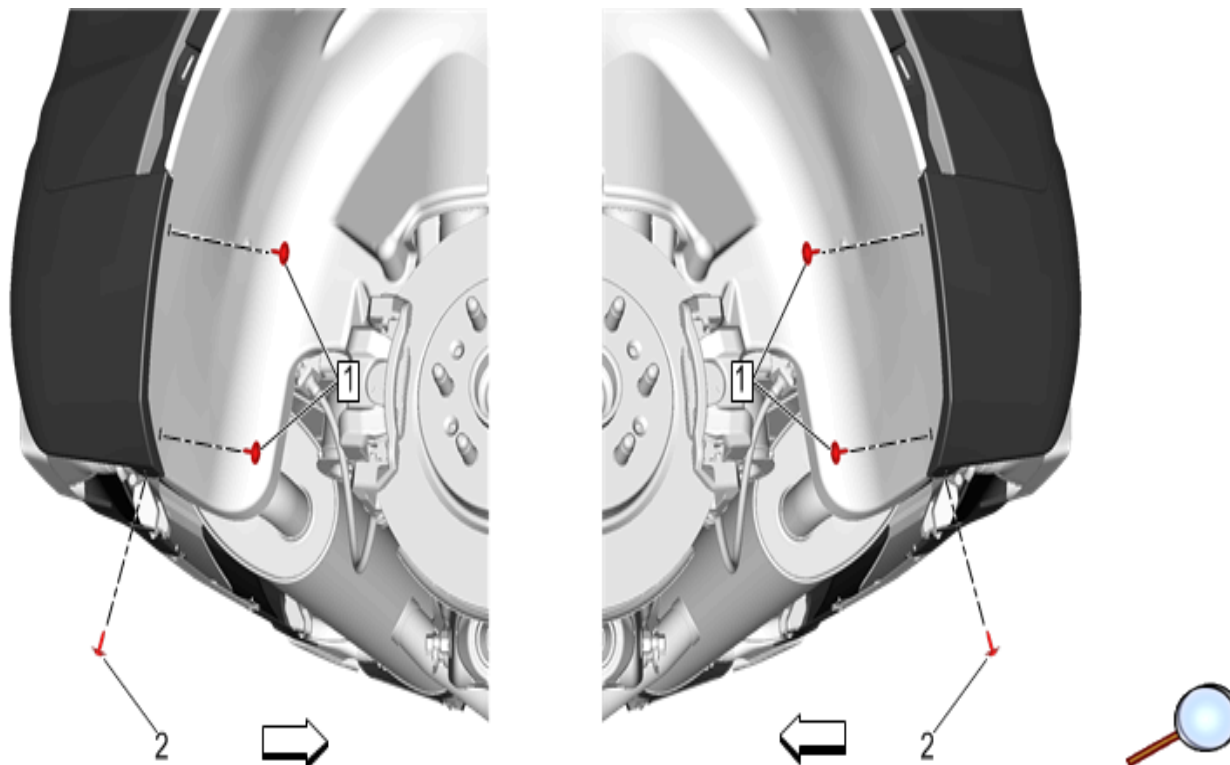

6. Remove the screws (1) securing rear fascia to side of vehicle. Upon reassembly tighten the screws to  $2.5 \pm 0.5$  Nm.
7. Remove the screws (2) securing the outer lower rear fascia. Upon reassembly tighten the screws to  $2.5 \pm 0.5$  Nm.

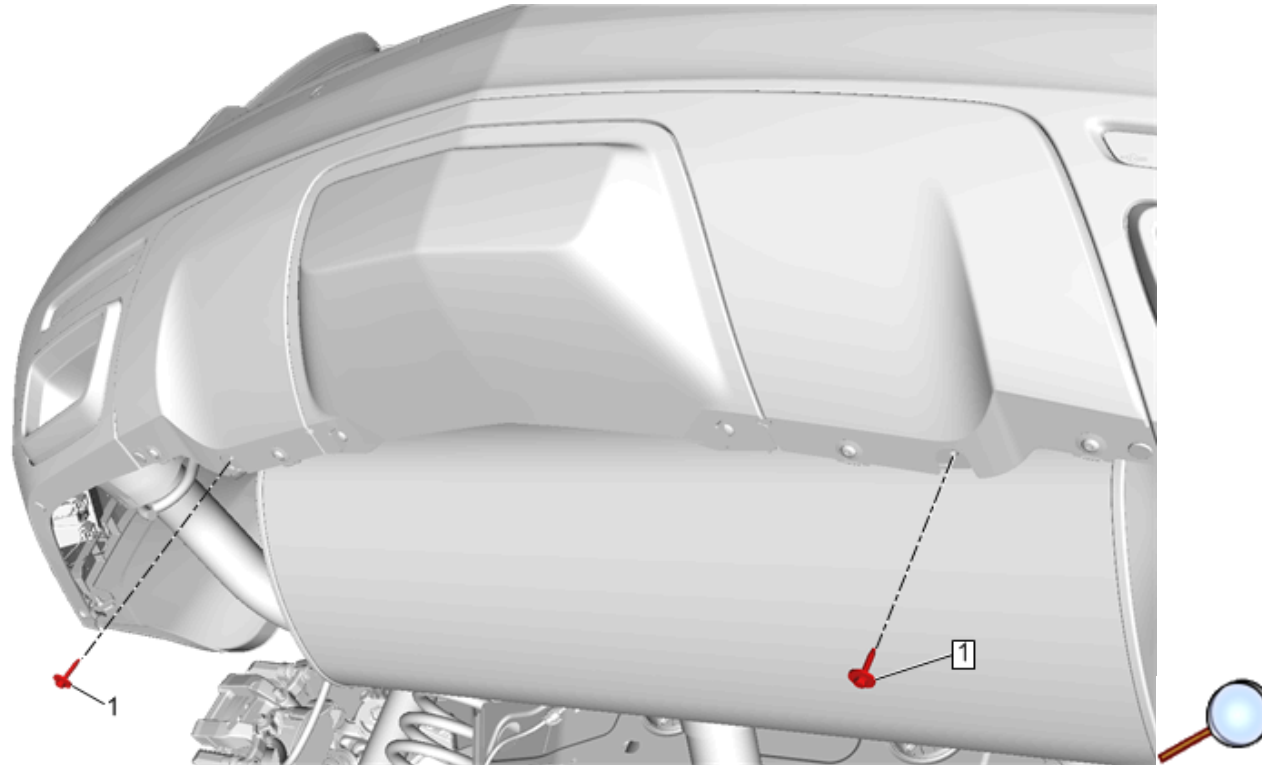

8. Remove the screws (1) from the rear lower fascia. Upon reassembly tighten the screws to  $2.5 \pm 0.5$  Nm.



9. Carefully push a small nylon wedge between the fascia and the rear fascia guide. Insert a small flat-bladed tool into the fascia slot and depress the snaps one at a time and pull on the fascia at the same time to gradually remove the rear fascia (1) from the rear fascia guide.

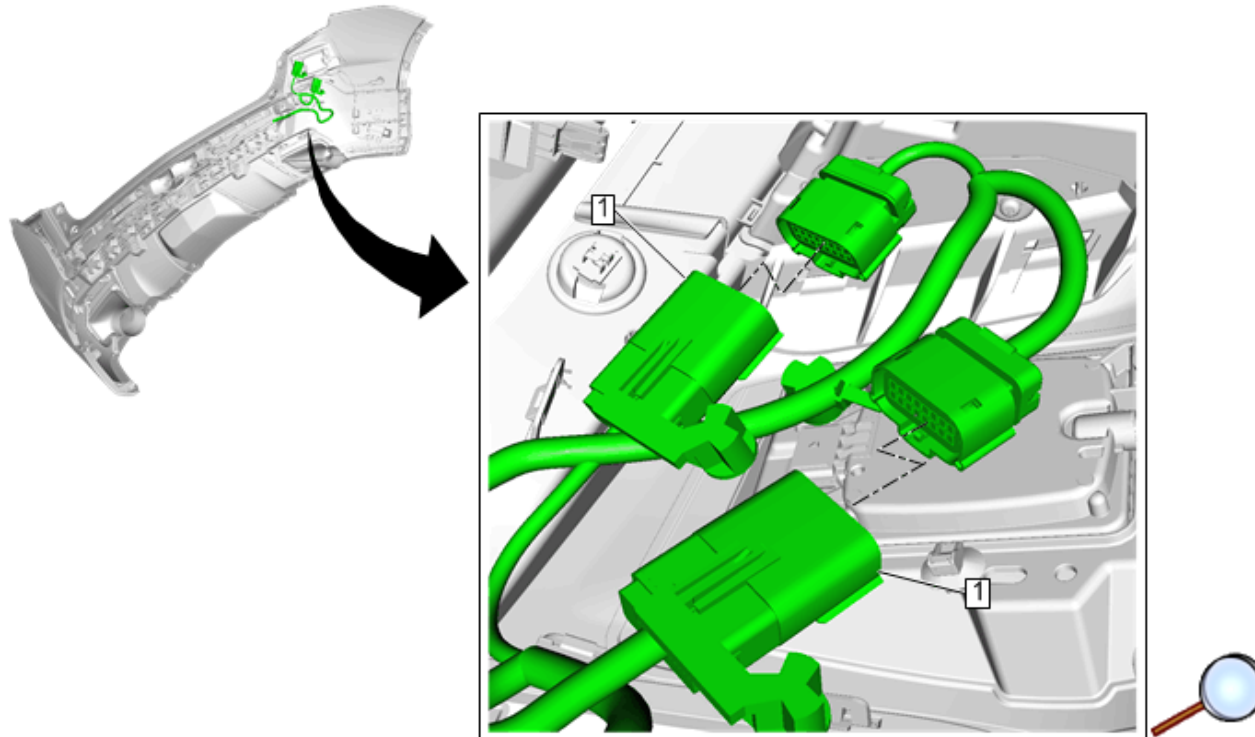

10. Disconnect the rear fascia harness electrical connectors (1) from the rear body harness.

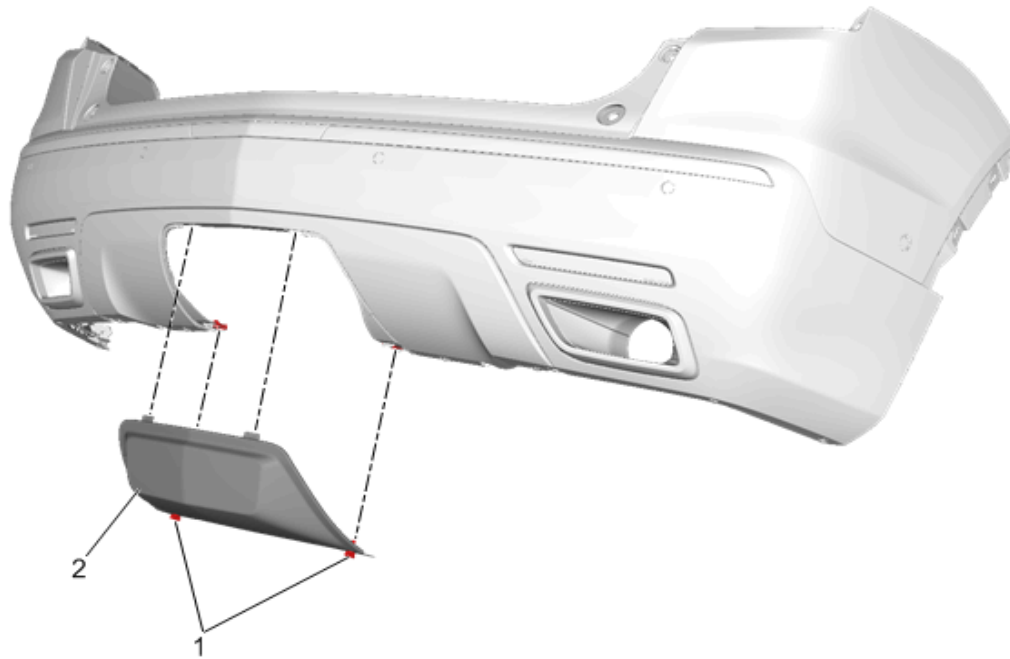

11. Loosen the fasteners (1) and remove the rear fascia close out panel (2) from the rear fascia.

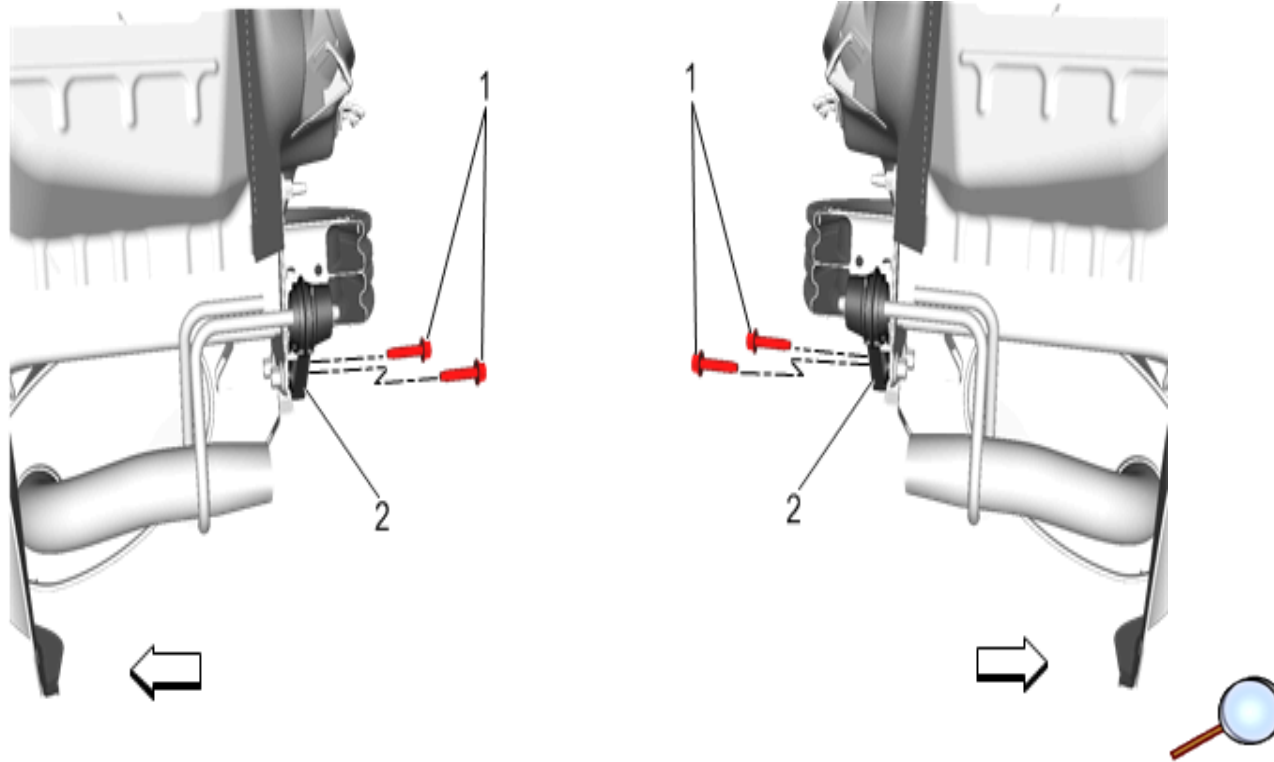

12. Remove and retain the bolts (1) securing the rear exhaust hangers (2) to the rear impact bar.



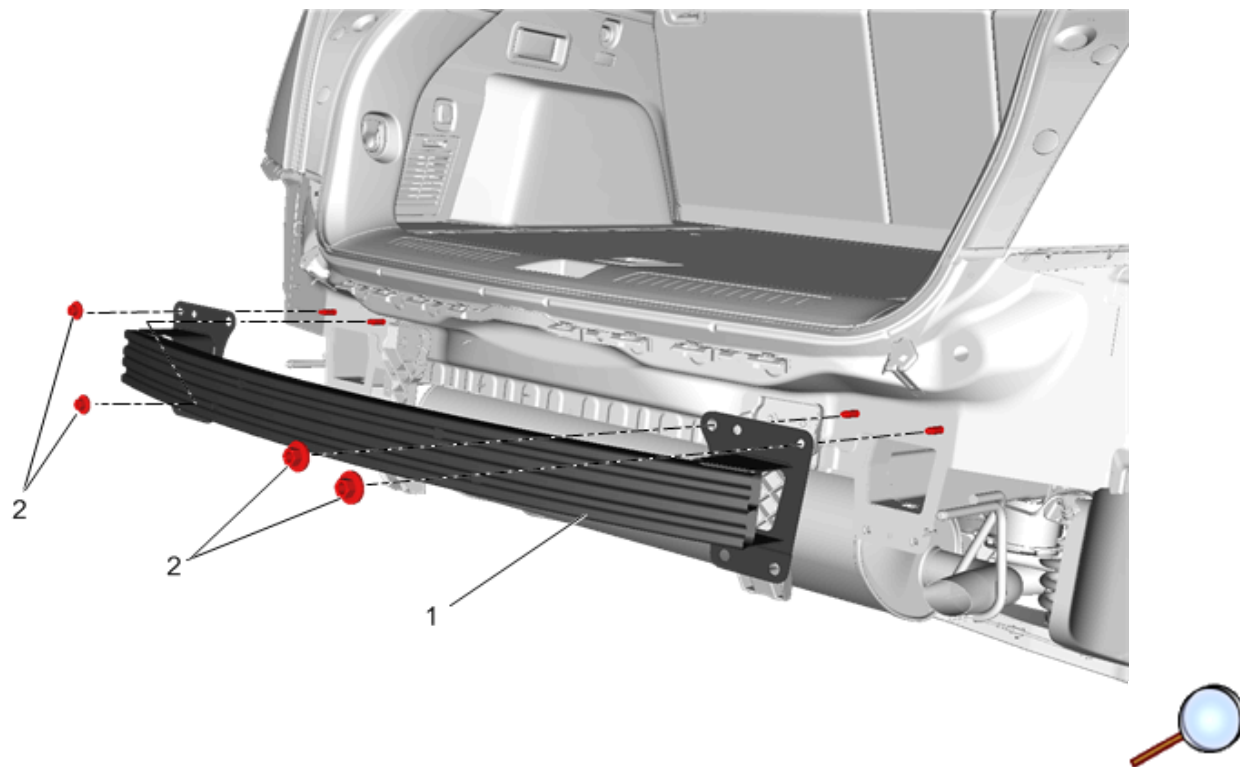

13. Remove and retain the nuts (2) securing the rear fascia impact bar.
14. Remove the rear fascia impact bar (1) from vehicle.

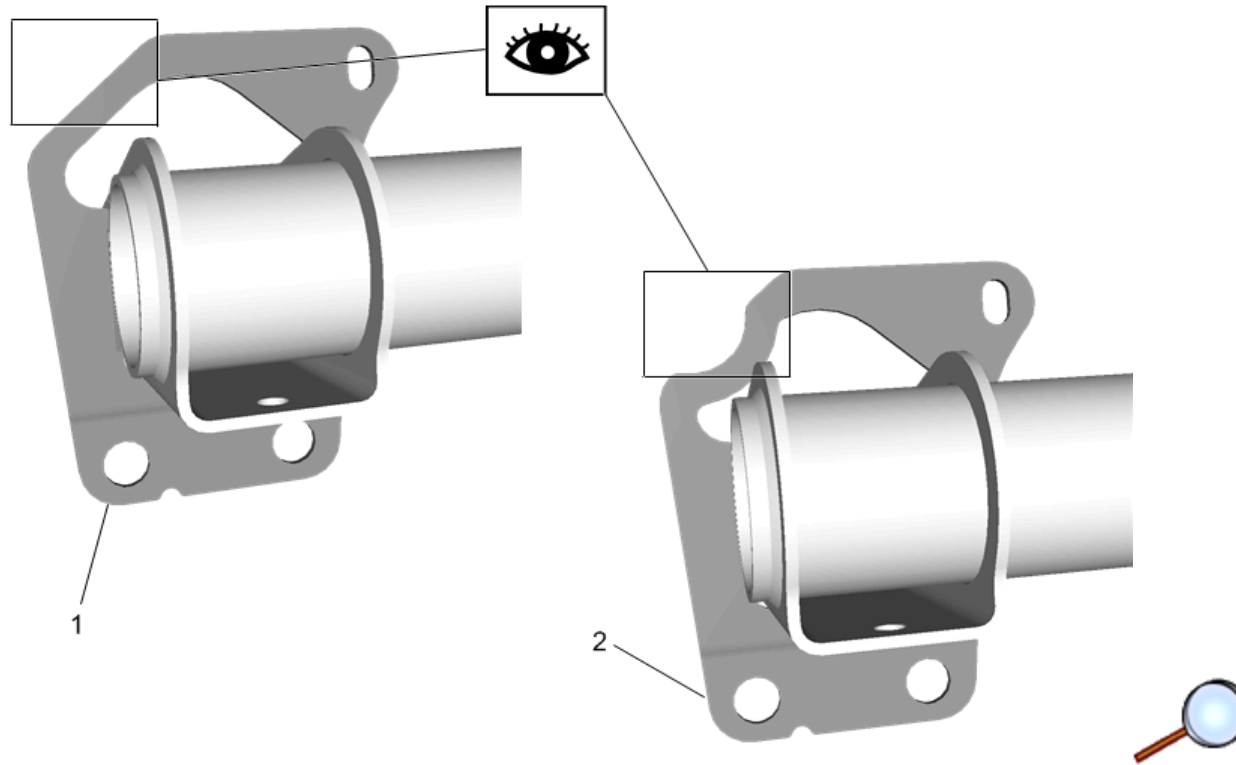

15. Identify the hitch options to further identify installation procedure.

15.1. If this version of hitch (1), follow instructions below to seal stud with sealant.

15.2. I this version of hitch (2), place previously existing nut over stud.

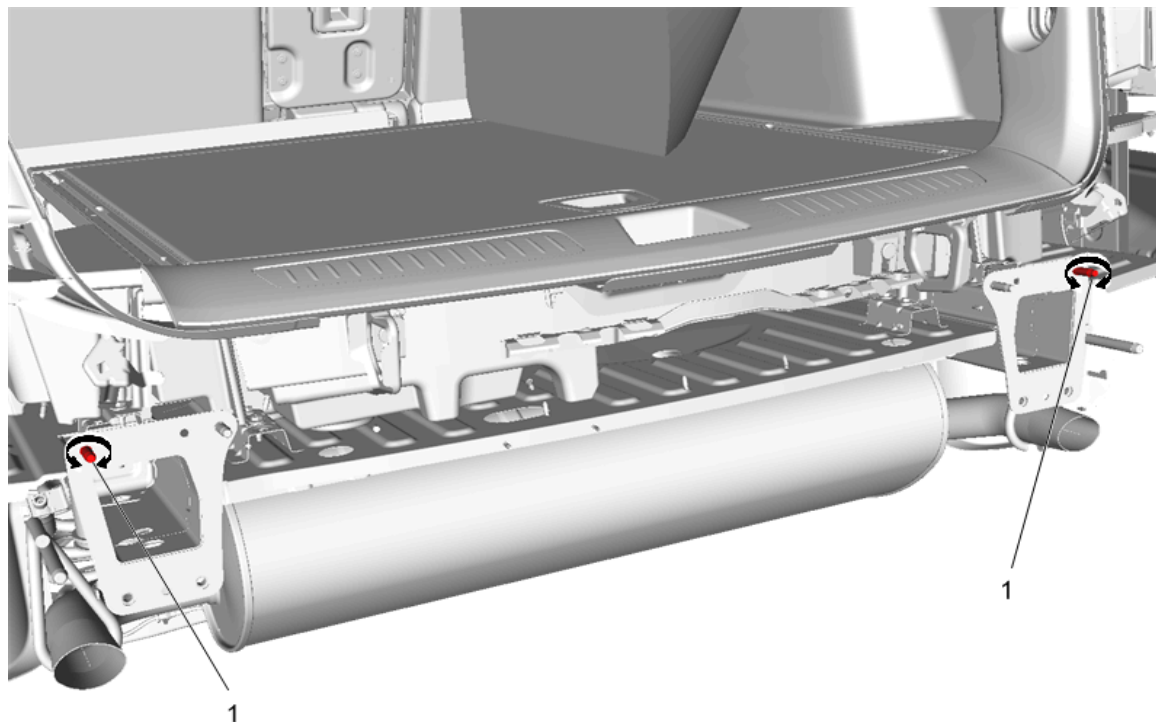

## 16. 2017 Cadillac XT5 Dealer Hitch Sealer Addition:

16.1. For vehicles that have hitch packages (84114399 – Cadillac XT5 installed at dealerships. Sealant must be added around the base of the unused stud (1), sealing the pass through the hole in rear end panel. In the form of:

- Silicone
- Kent Seam Sealer
- 3M® Strip Caulk
- Mastic Patch

16.2. Sufficient sealant should be used to allow for complete water seal around the whole perimeter.

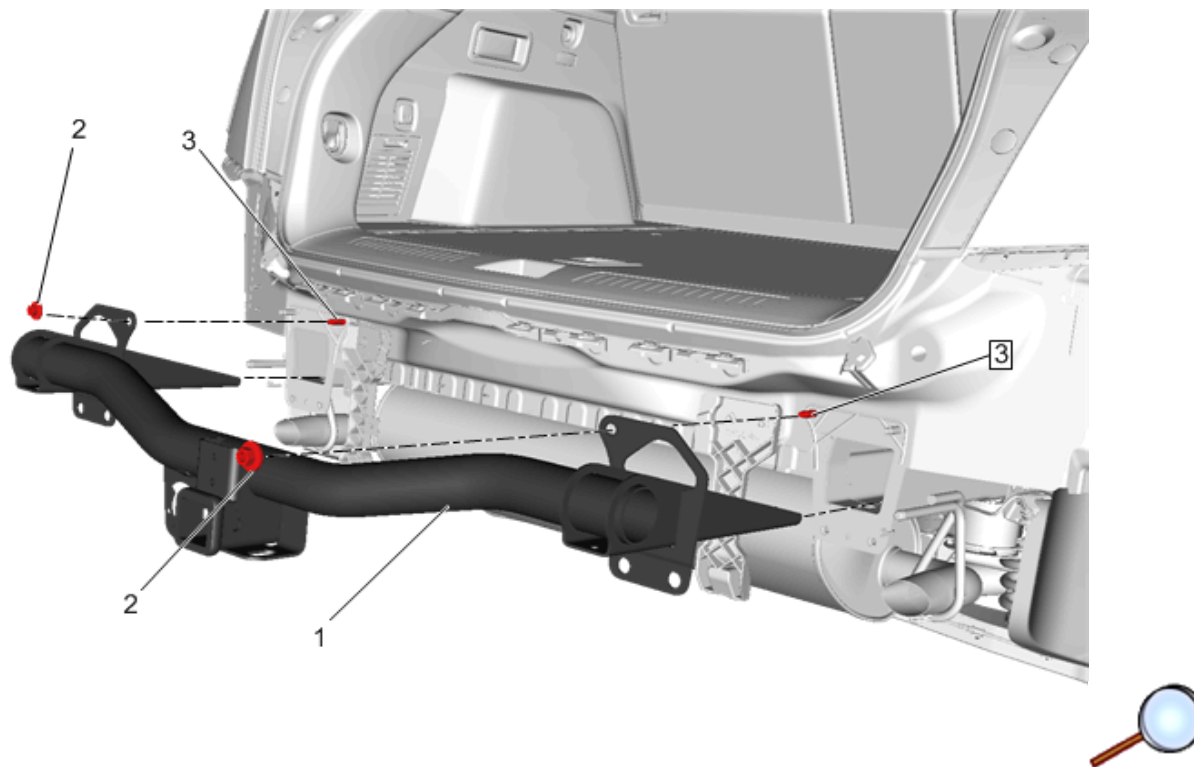

**Caution:** Use the correct fastener in the correct location. Replacement fasteners must be the correct part number for that application. Fasteners requiring replacement or fasteners requiring the use of thread locking compound or sealant are identified in the service procedure. Do not use paints, lubricants, or corrosion inhibitors on fasteners or fastener joint surfaces unless specified. These coatings affect fastener torque and joint clamping force and may damage the fastener. Use the correct tightening sequence and specifications when installing fasteners in order to avoid damage to parts and systems.

17. With the aid of an assistant, insert the platform assembly – trailer hitch (1) into the body rails. Secure with previously retained nuts (2) to the studs (3).

**Tighten**

Tighten the nuts to  $58 \pm 9$  N.m.

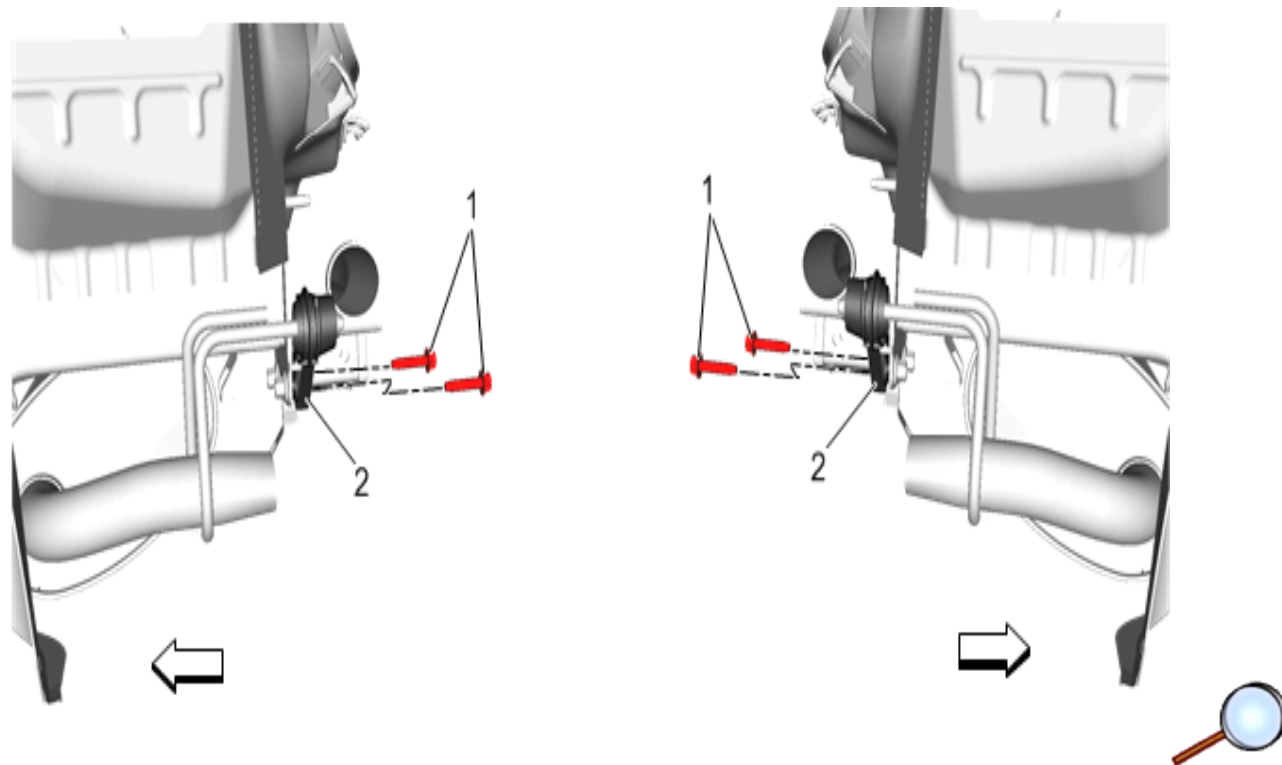

18. Install the rear exhaust hangers (2) to the platform assembly – trailer hitch and install the previously retained bolts (1).  
**Tighten**  
Tighten the bolts to  $58 \pm 9$  N.m.

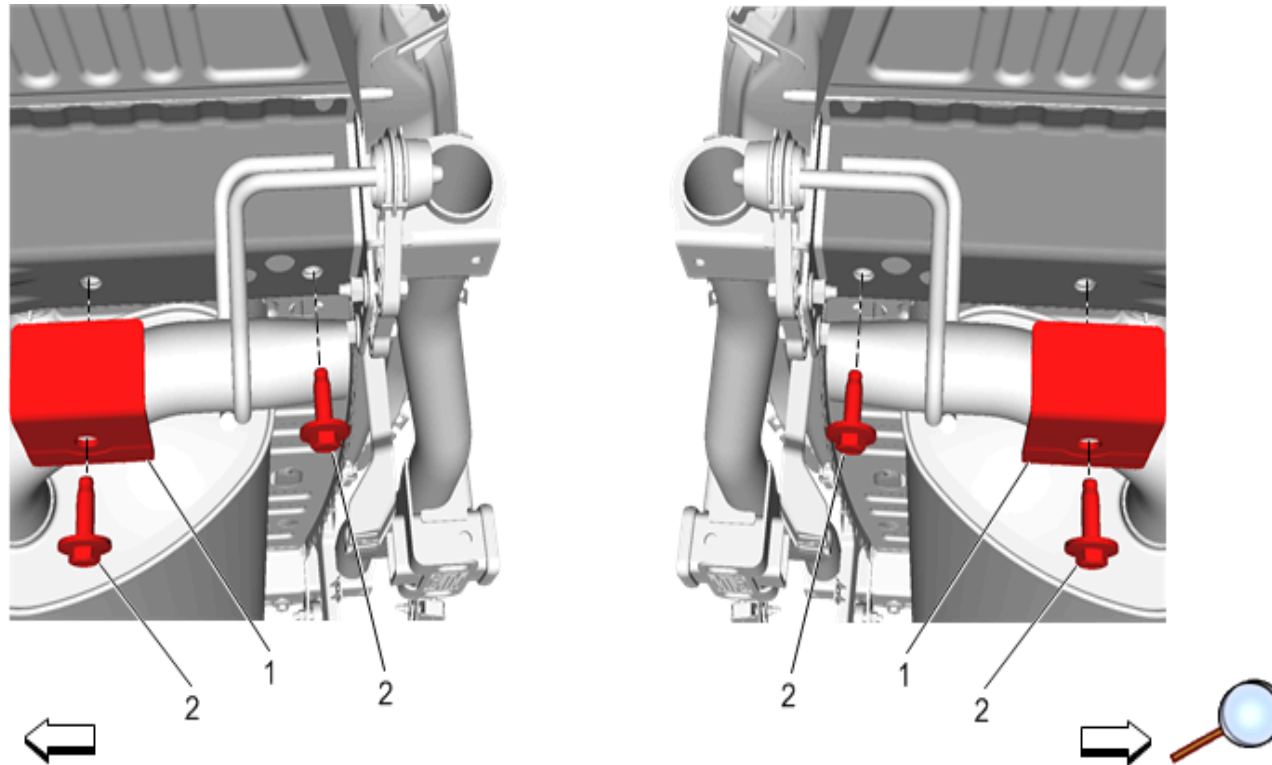

19. With the raised lip to the outside install the reinforcement plates (1) to the under side and secure the platform assembly – trailer hitch with the supplied M12 x 1.75 x 35 bolts (2).

**Tighten**

Tighten the M12 x 1.75 x 35 bolts to  $100 \pm 15$  N.m.

20. **Install trailer wiring harness to platform assembly – trailer hitch by following steps below.**

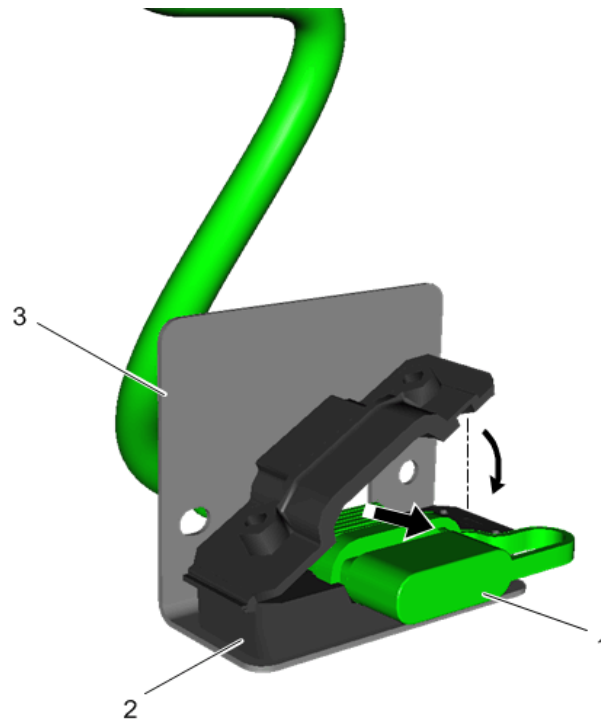

21. On the bench, put the connector (1) through "L" bracket opening (3).
22. Put the clam shell bracket (2) around the connector, carefully positioning the tether.

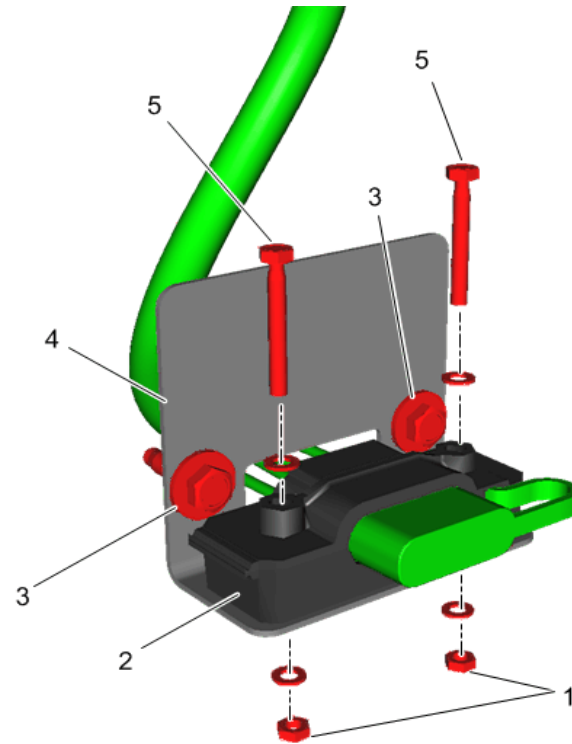

23. Place the M6 bolts (3) through the holes in the "L" bracket (4).

24. Assemble the M4 fasteners (5) and plastic bracket/connector (2) to the "L" bracket. Finger start the M4 nuts (1) and leave loose.



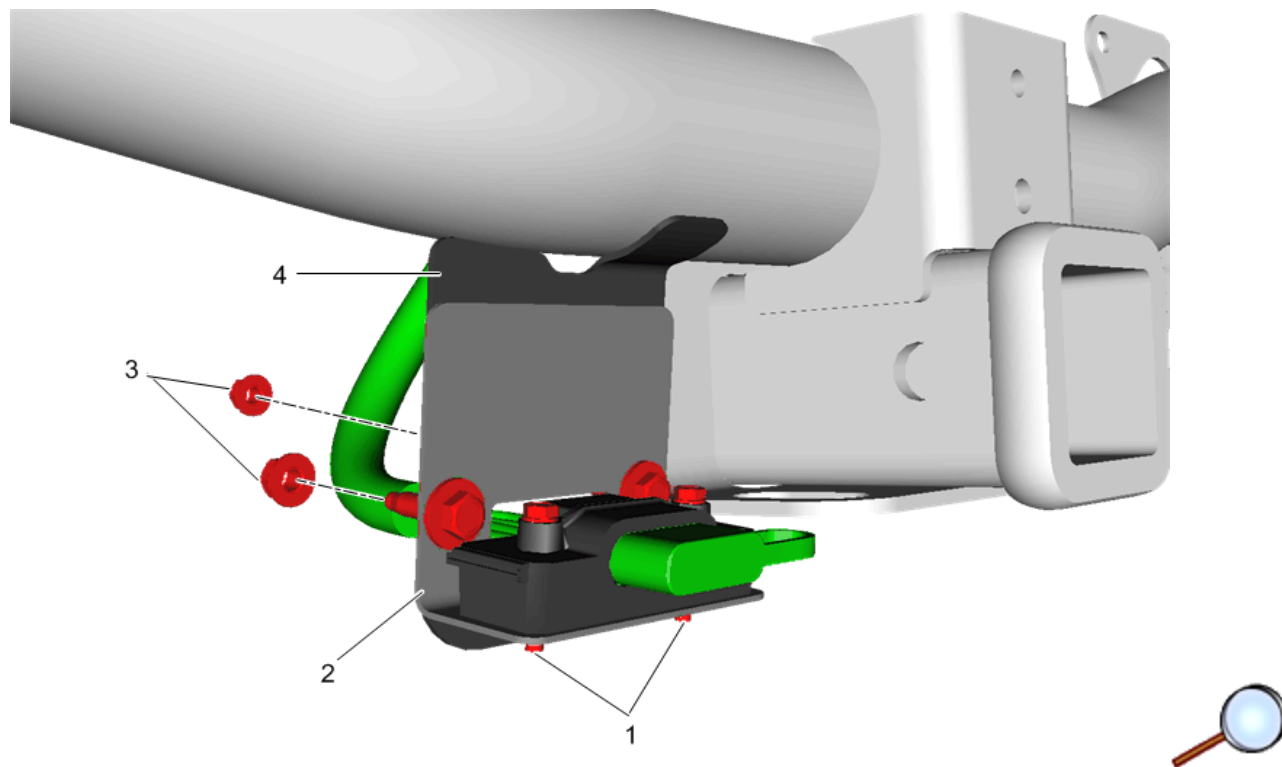

25. Place the "L" bracket (2) against the hitch plate (4) and attach the two M6 torque prevailing nuts (3) with a 10mm wrenches using 9 N.m of torque.
26. Tighten the two M4 nuts (1) with 7mm wrenches using 0.7 N.m of torque.

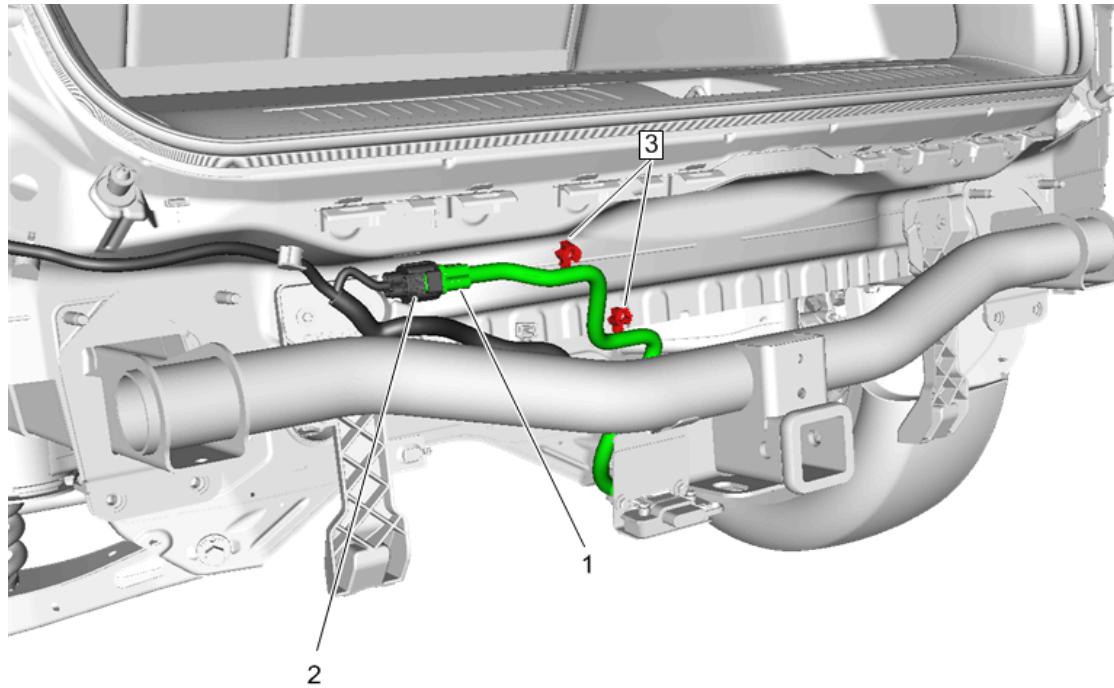

27. Push on the two harness stud clips (3).
28. Remove body harness cap and connect trailer harness (1) to body harness (2).

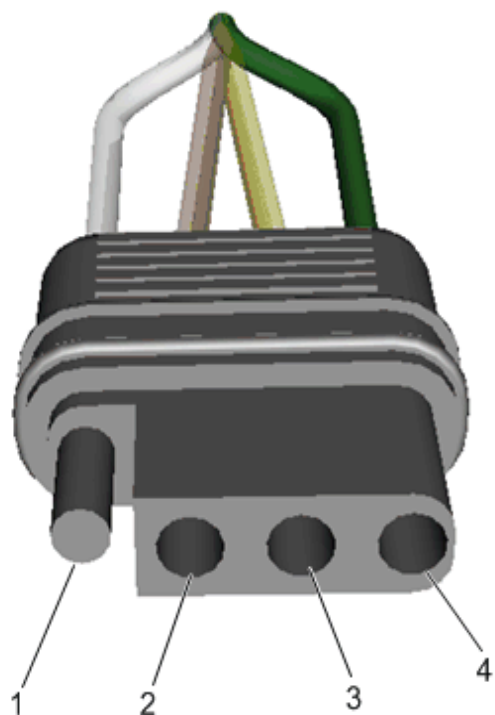

#### 29. Checkout Procedure

- **Option 1** is to check connector circuit function by using a readily available test connector w/LED's as shown. Actuate vehicle tail lamps, left turn signals, right turn signals.
- **Option 2** is to use test light or volt meter.
  - Ground (WHITE wire) is (1) above.
  - Tail lamps (BROWN wire) is (2) above.
  - Left turn signal (YELLOW wire) is (3) above.
  - Right turn signal (GREEN wire) is (4) above.

30. With the aid of an assistant, position the rear fascia to vehicle, connect rear fascia harness connectors to rear body harness and install the rear fascia in the reverse order that it was removed.

31. Reinstall any previously removed components.