

Side Door Sill Trim Plate Package Installation

Installation Instructions Part Number

23248218

Kit Contents

Side Door Sill Trim Plate Package Installation

DESCRIPTION	QUANTITY
SILL PLATE	2
ALCOHOL PREP PAD	2
INSTALLATION INSTRUCTIONS	1

Tools Required

- Soft, Lint-Free Towels
- Heat Gun (If required)
- Masking Tape

Preparation - Before Installation

1. If existing parts are installed, carefully remove them. Use approved adhesive remover (VMP Naptha), to remove any adhesive residue.
2. After opening the kit, check to see if any parts are missing and that the product is not damaged.
3. This product should be installed with proper installation tools.
4. Install this product while observing all warnings and precautions stated in this instruction sheet.
5. Thoroughly wash entire surface area where parts will be adhered to.
6. Temperature of sill plates and the vehicle must be 70°F to 90°F (21°C to 32°C).

Installation Procedure

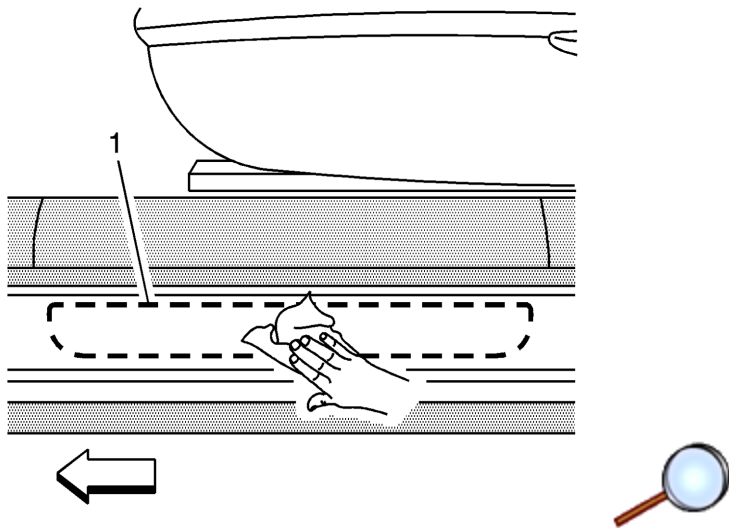

1. Wipe area (1) where the sill plate is to be applied using supplied alcohol prep pad and follow with a dry wipe to remove any residual alcohol.

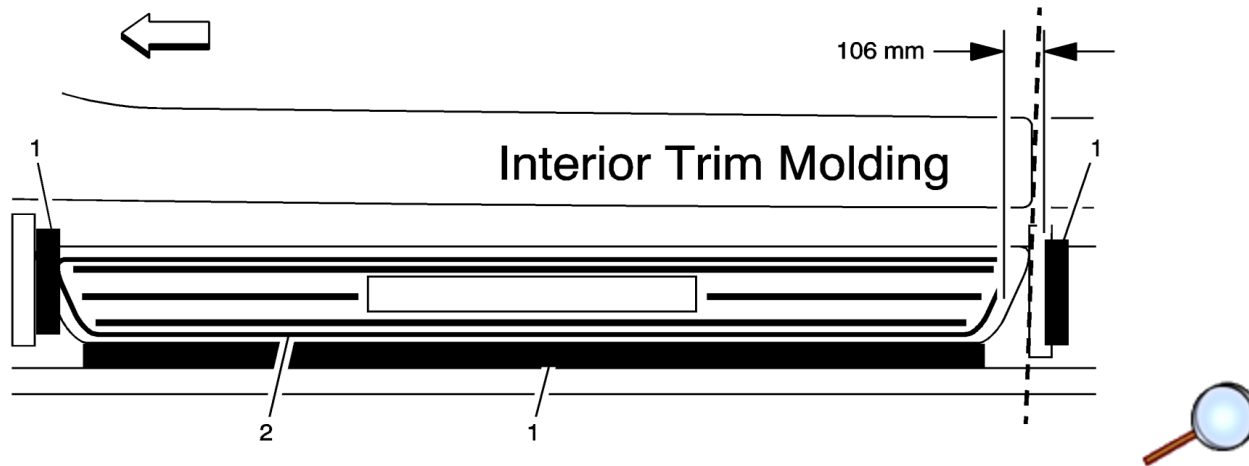

2. Prior to removing backing liner, position parts (2) in proper location and use masking tape (1) to mark location.

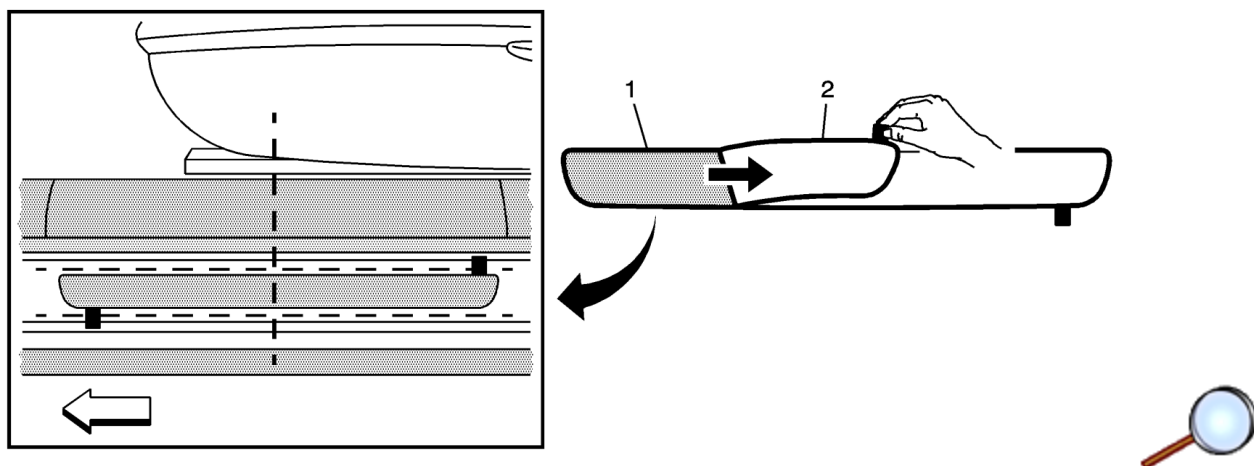

3. Lay the sill plate (1) face down on a flat surface and carefully remove the backing paper liner (2) from the plate.

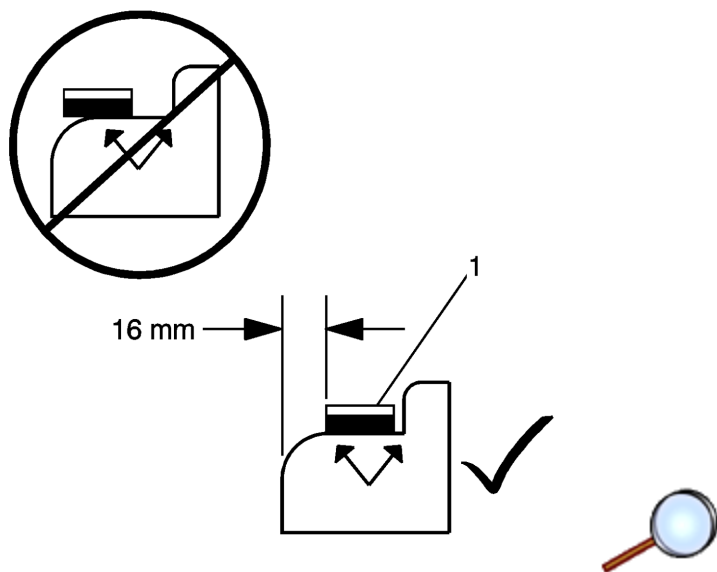

4. Carefully lift the sill plate along the edges (do not touch the exposed adhesive) and align the parts to the masking tape locations. Do not apply pressure until the positioning is satisfactory. **MAKE SURE LEADING EDGE OF PART (1) REMAINS ON FLAT AREA OF SURFACE.**

Note: Repositioning is not recommended but can occur if the plate has not been pressed into place.

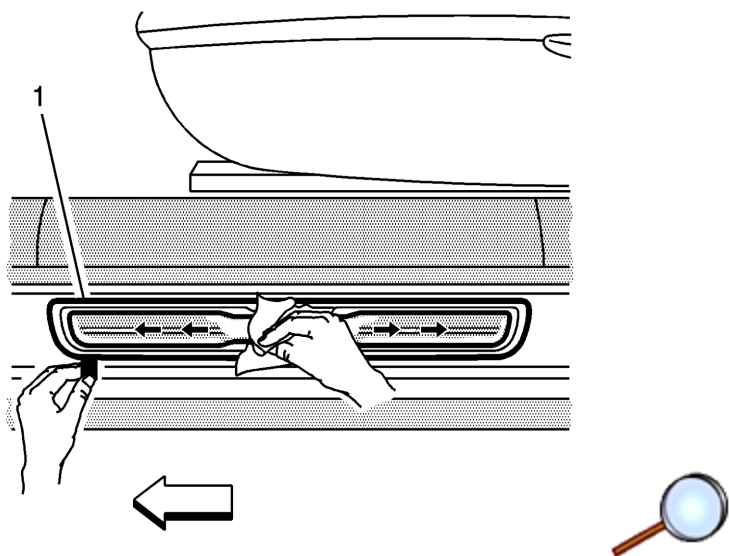

Important: Hand pressure may not provide the necessary "wet out".

5. Apply firm pressure onto the plates (1) starting from center and moving outboard. Use firm, overlapping strokes and apply pressure around the perimeter of the plate multiple times.
6. For optimum performance, use a heat gun to apply heat (120°F for 3 seconds) across the surface of the plate and then re-press into place with felt block.
7. Repeat steps 1 through 6 for the remaining sill plates.