

## Installation Instructions Part Number

23306540

### Kit Contents

Qty	Description
1	Emblem Assembly Gold Bow Tie – Front Grille Illumination (P/N 23306536)
1	Harness Package
4	Tie Strap
1	Installation Instructions
<b>OR</b>	
1	Emblem Assembly Black Bow Tie – Front Grille Illumination (P/N 23385941)
1	Harness Package
4	Tie Strap
1	Emblem Assembly Black Bow tie – Endgate
1	Solvent Package
1	Installation Instructions

### Required / Recommended Tools

Drill Motor

12.7 mm Drill Bit

Heat Gun or Equivalent

### Procedure

1. **Front Bow Tie Emblem Replacement.** Read all instructions before performing procedure.
2. Inspect kit to verify all parts are included.
3. Turn off the vehicle.
4. Open the hood.

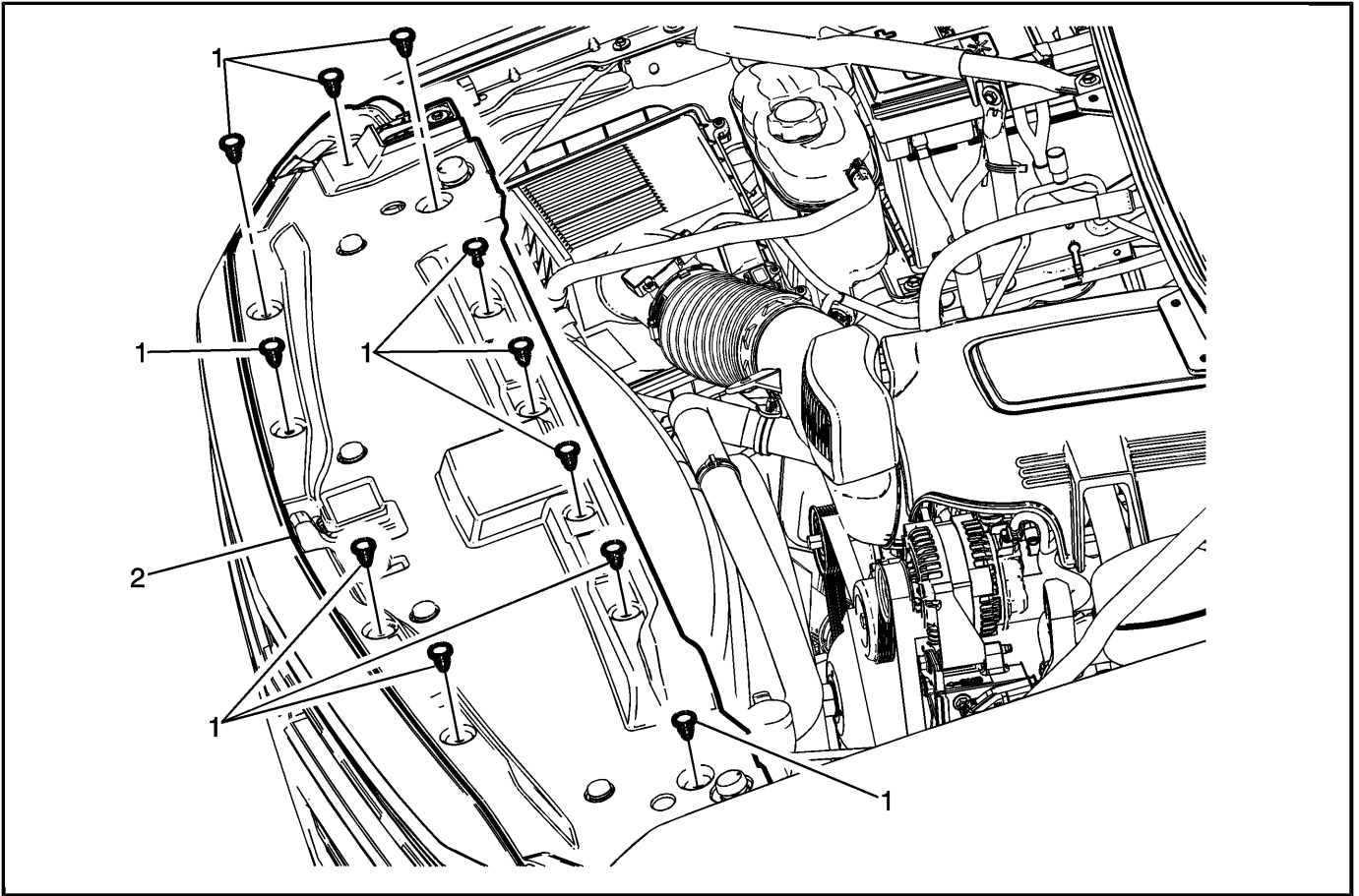

3247856

5. Remove the front compartment front sight shield push-in retainers (1).
6. Remove the air cleaner assembly. Refer to Vehicle Service Manual.

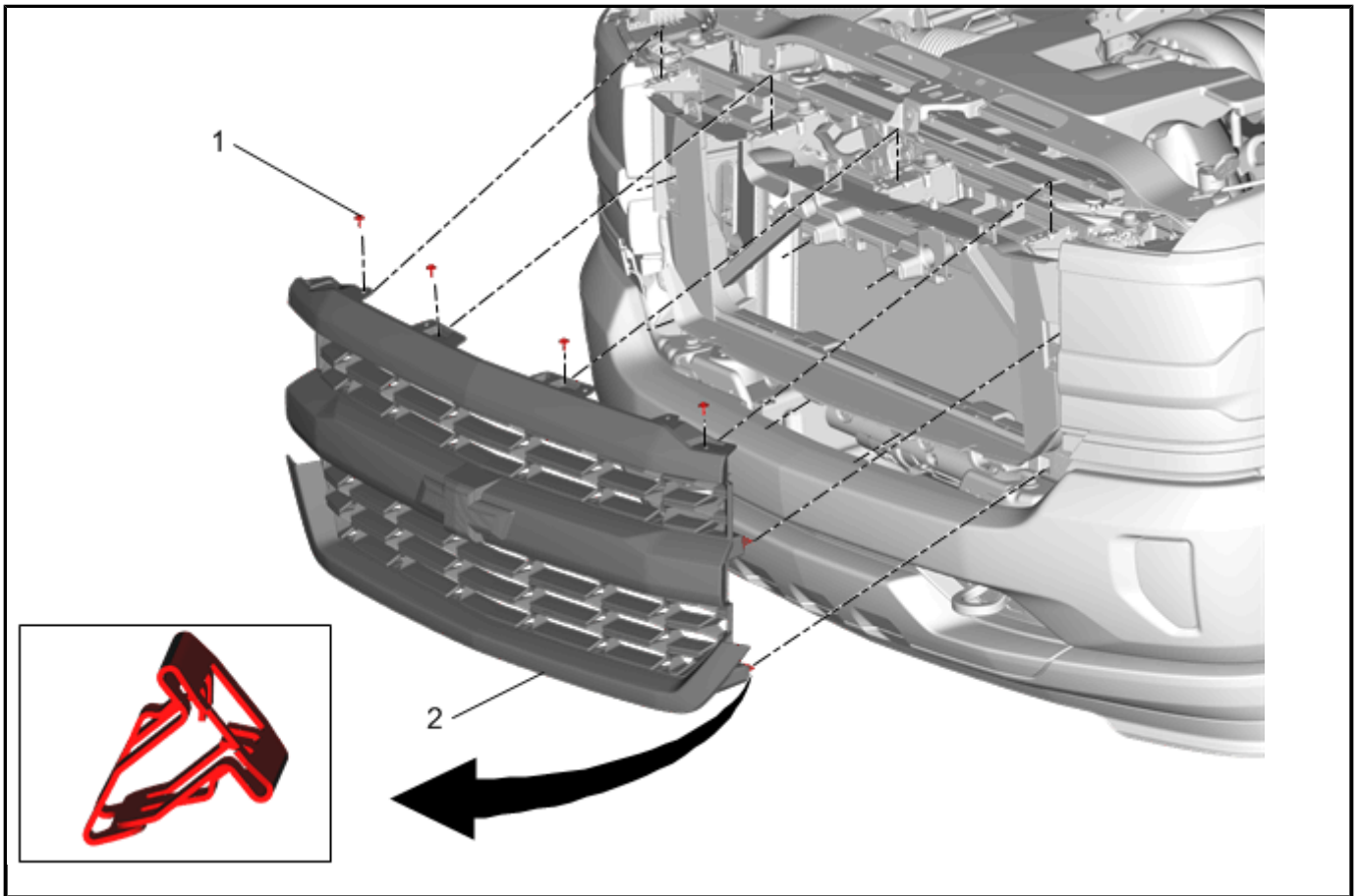

4250218

**Caution:** Use the correct fastener in the correct location. Replacement fasteners must be the correct part number for that application. Fasteners requiring replacement or fasteners requiring the use of thread locking compound or sealant are identified in the service procedure. Do not use paints, lubricants, or corrosion inhibitors on fasteners or fastener joint surfaces unless specified. These coatings affect fastener torque and joint clamping force and may damage the fastener. Use the correct tightening sequence and specifications when installing fasteners in order to avoid damage to parts and systems.

7. Remove the front grille bolts (1) Qty:4. Upon reassembly tighten grille bolts to 7 N.m (62 lb in).
8. With two hands and starting at either end firmly pull the front grille (2) releasing the 8 spring clips from the shutter body.

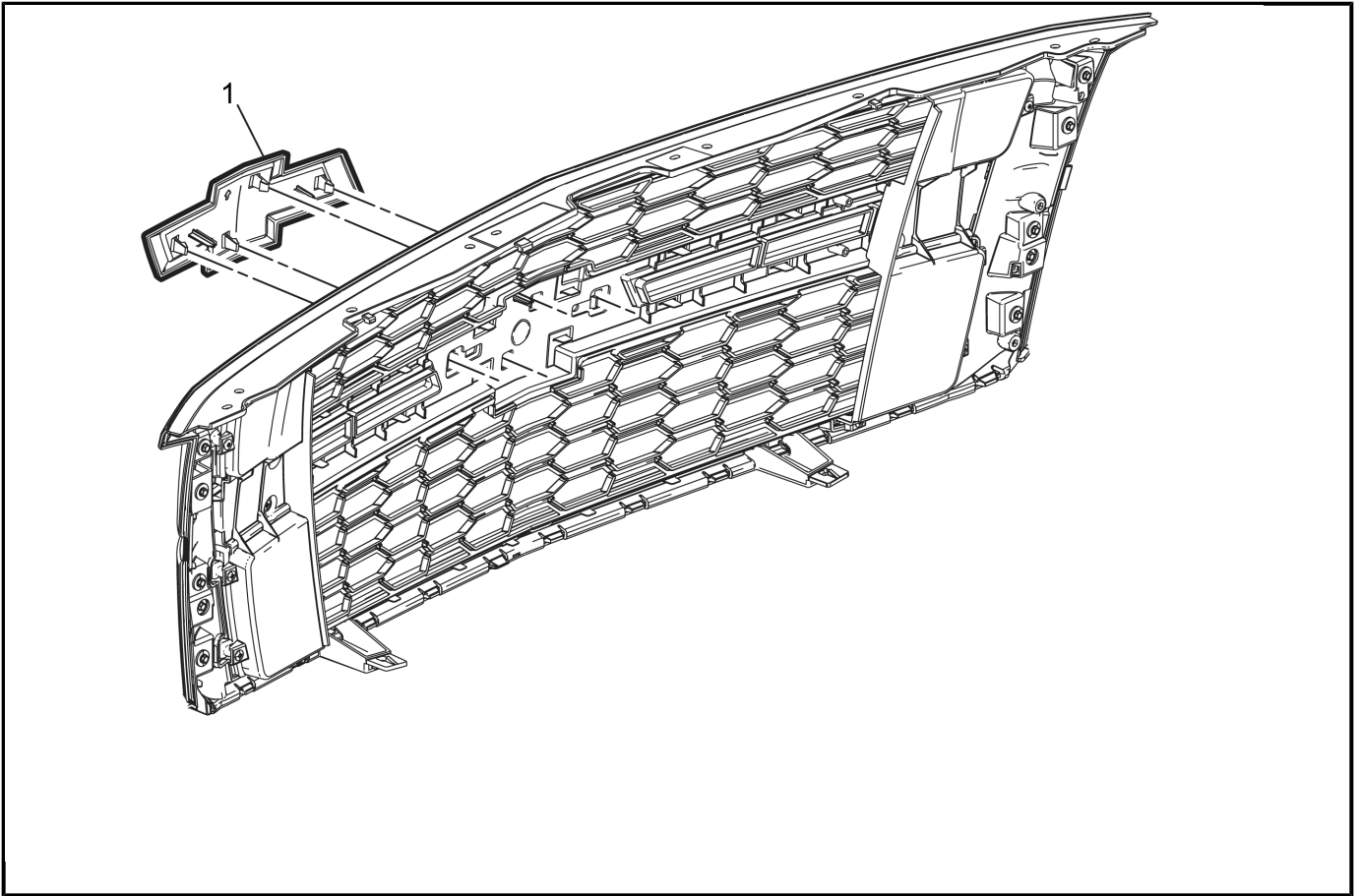

4436605

9. Using a suitable flat-bladed tool, release the 4 locking tabs and remove the front grille emblem (1) from the front grille.

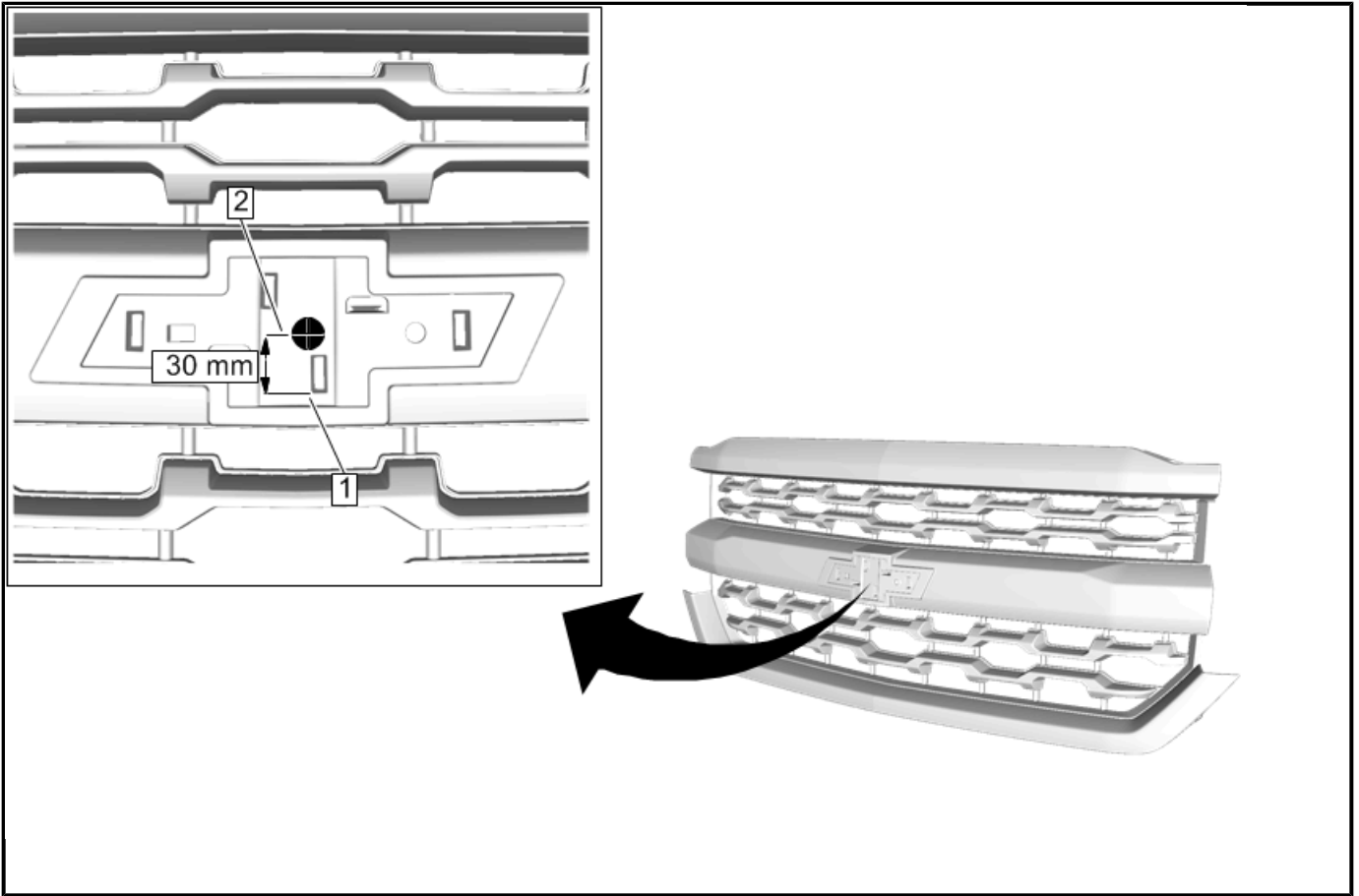

4434726

10. Measuring up 30 mm from the bottom of slot (1), using a 12.7 mm drill bit, drill a hole (2) in the front upper grille.

**Note:** Hole is not centered in emblem.

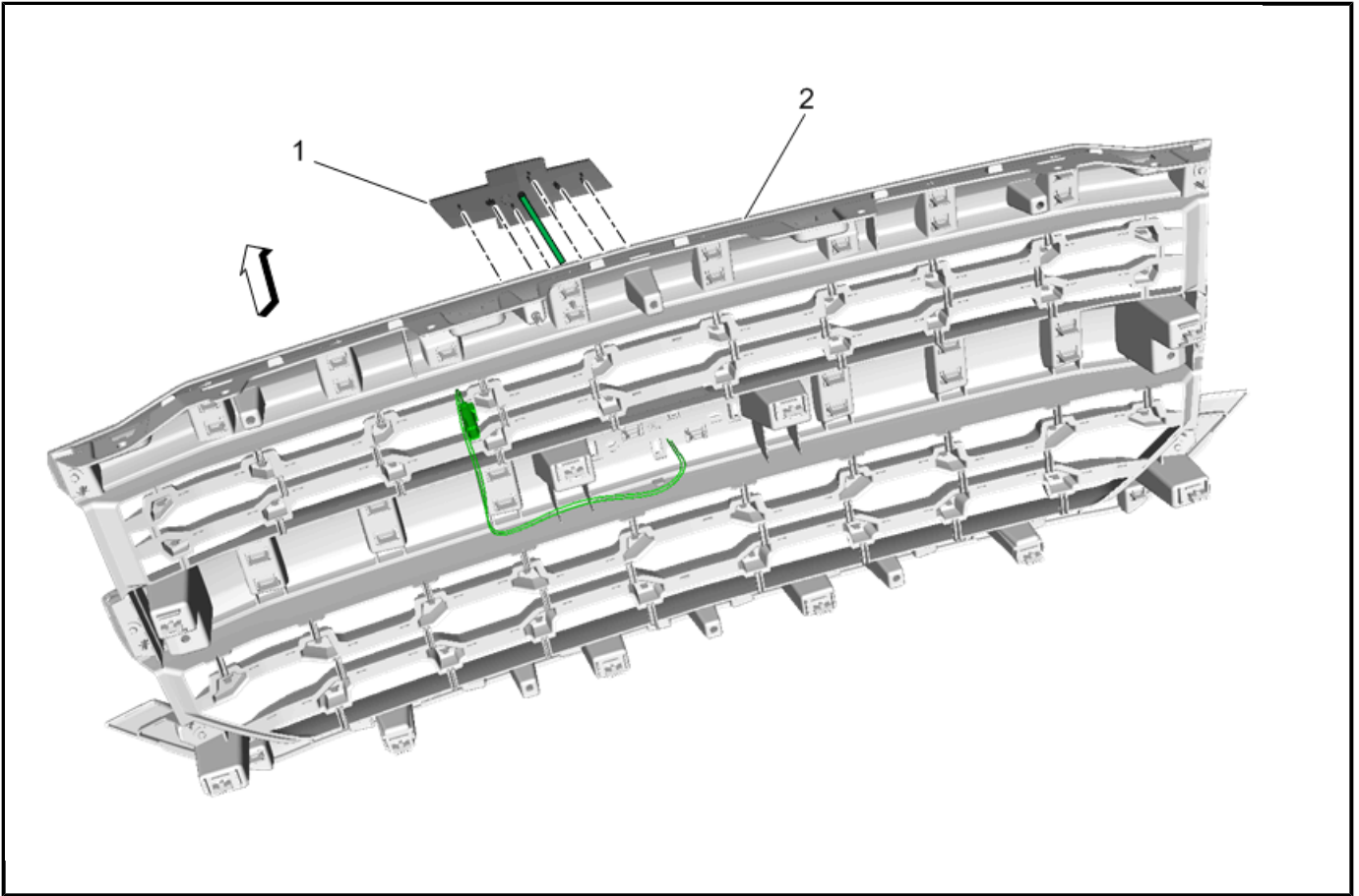

4435656

11. Install the illuminated emblem from kit (1) to the grille (2) by engaging the retaining tabs on the backside.

**Note:** If emblem does not snap into place, enlarge the drilled hole.

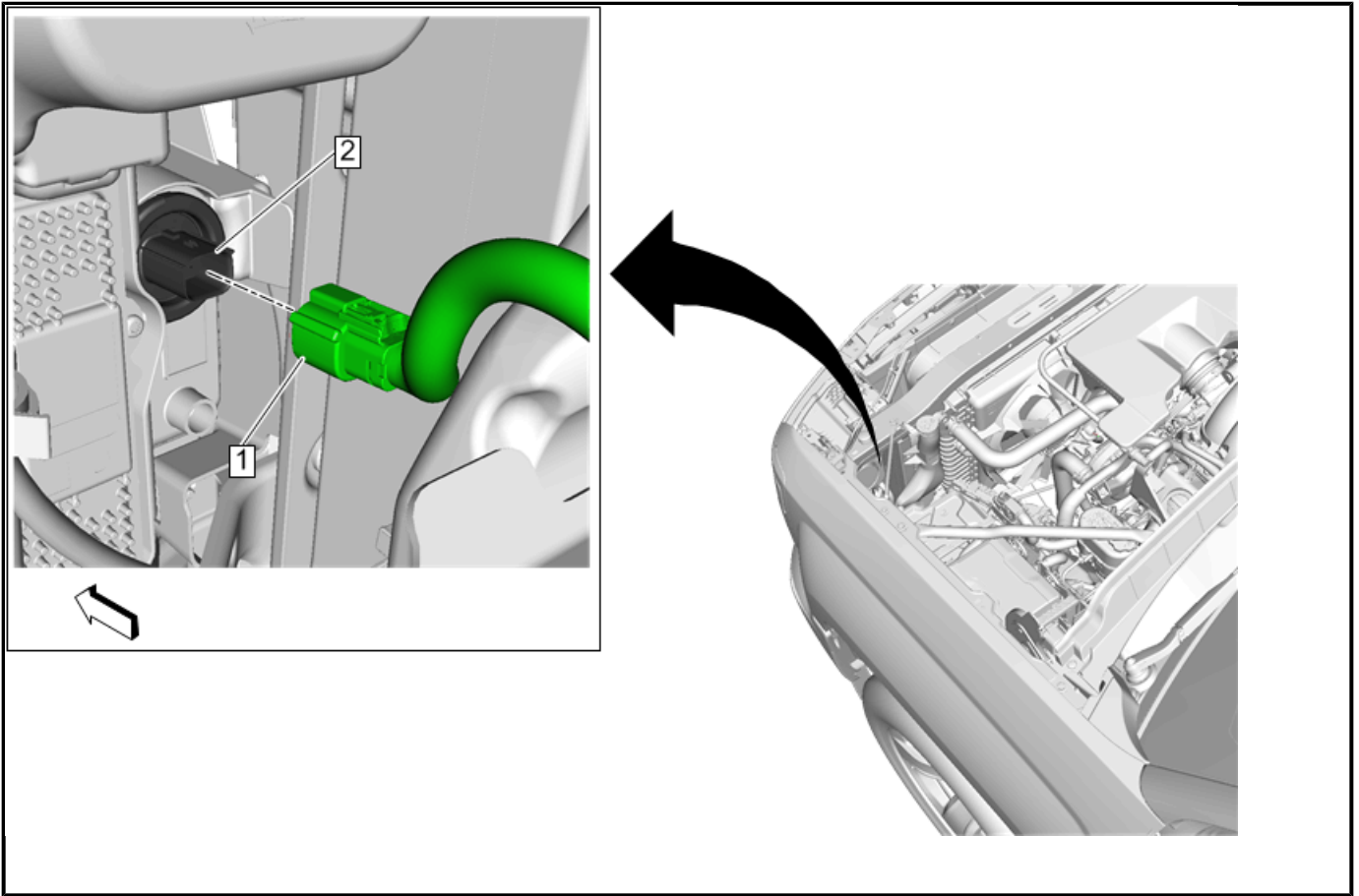

4435834

12. Disconnect the forward lamp lighting harness (1) from the driver side headlamp (2).

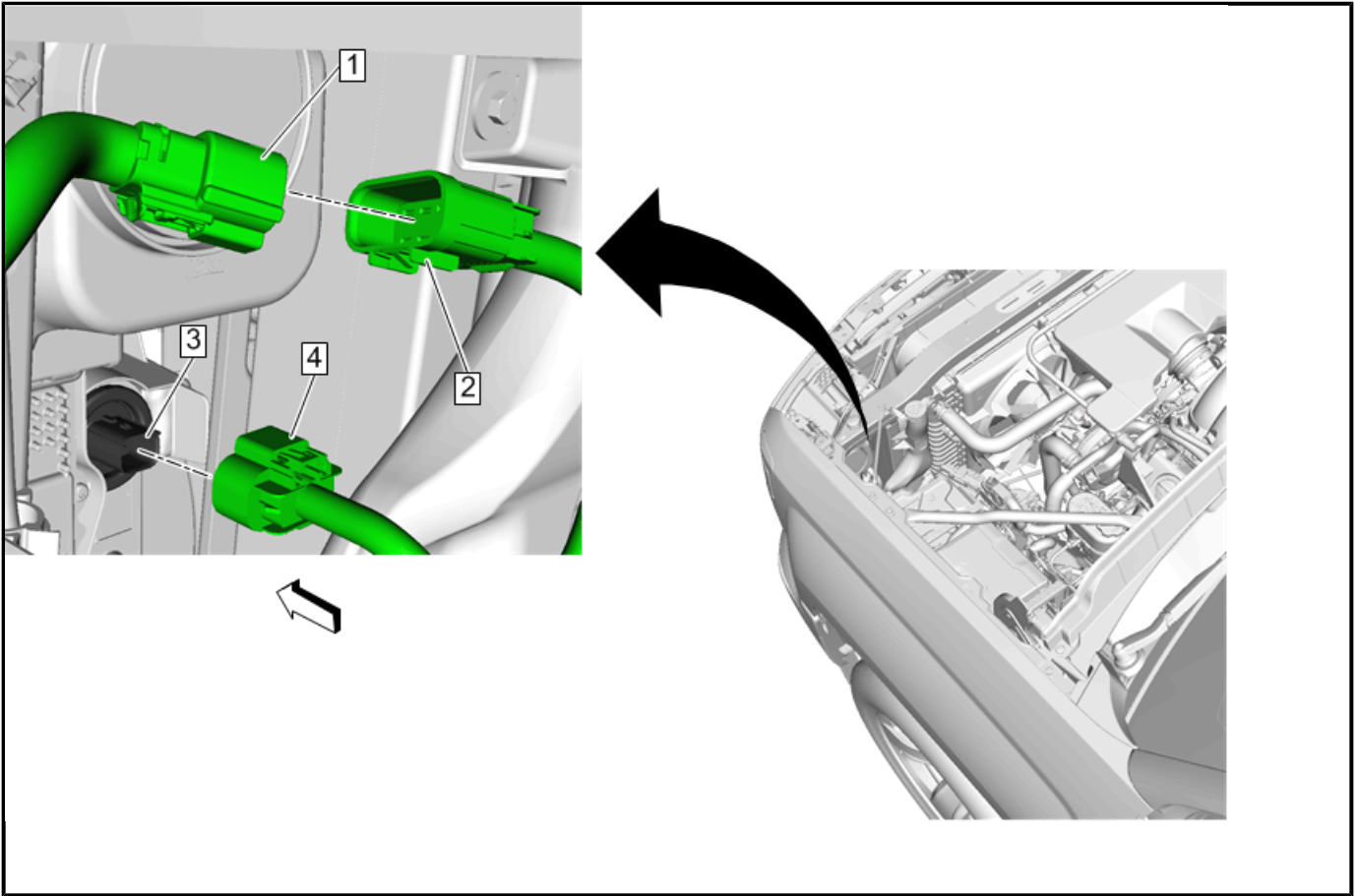

4436478

13. Connect the jumper harness connector (4) to driver side headlamp (3).
14. Connect the previously disconnected forward lamp lighting harness (1) to the jumper harness connector (2).



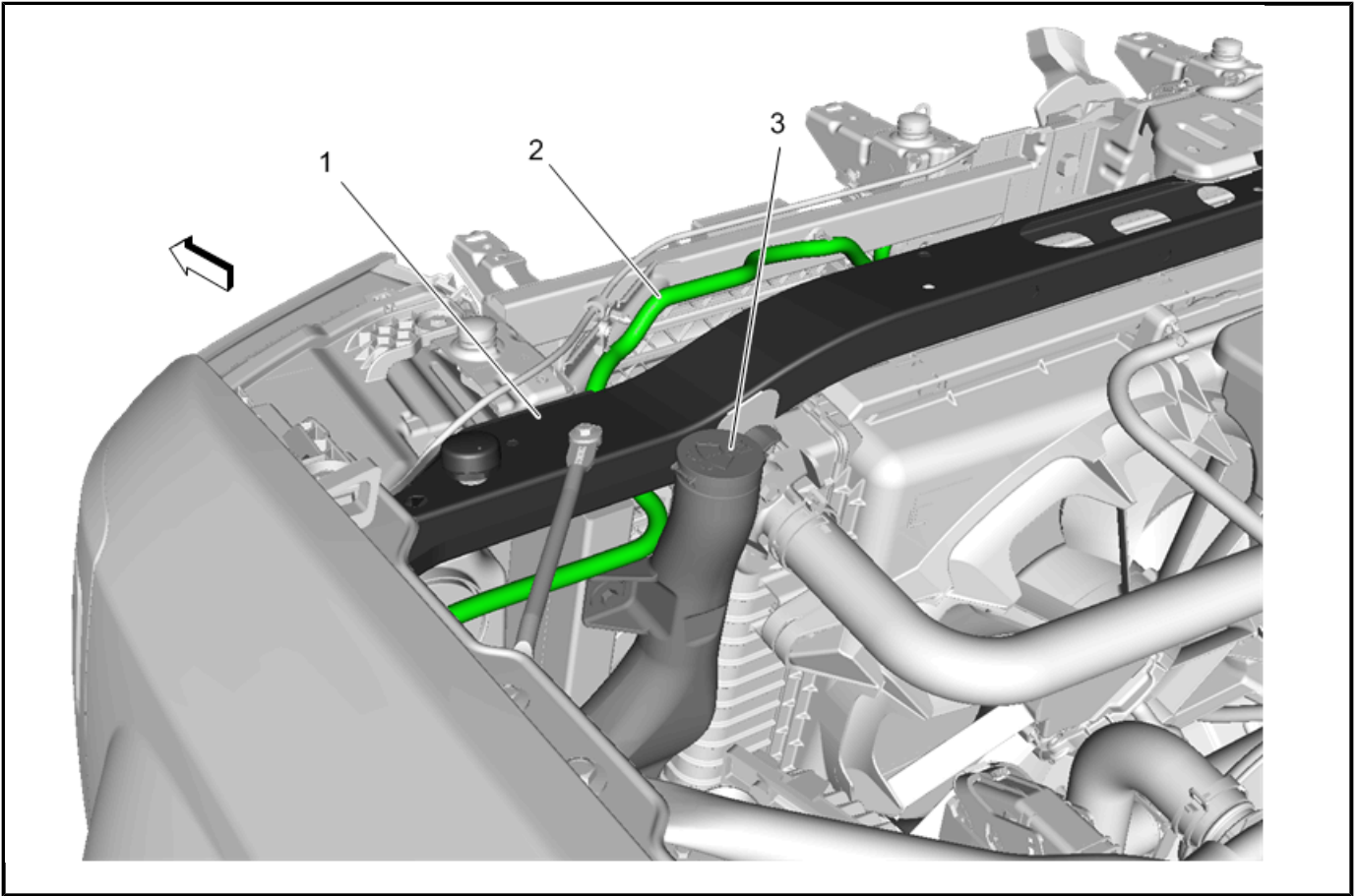

4436480

15. Route harness (2) in front of windshield wiper fluid bottle (3) and then under upper tie bar (1).

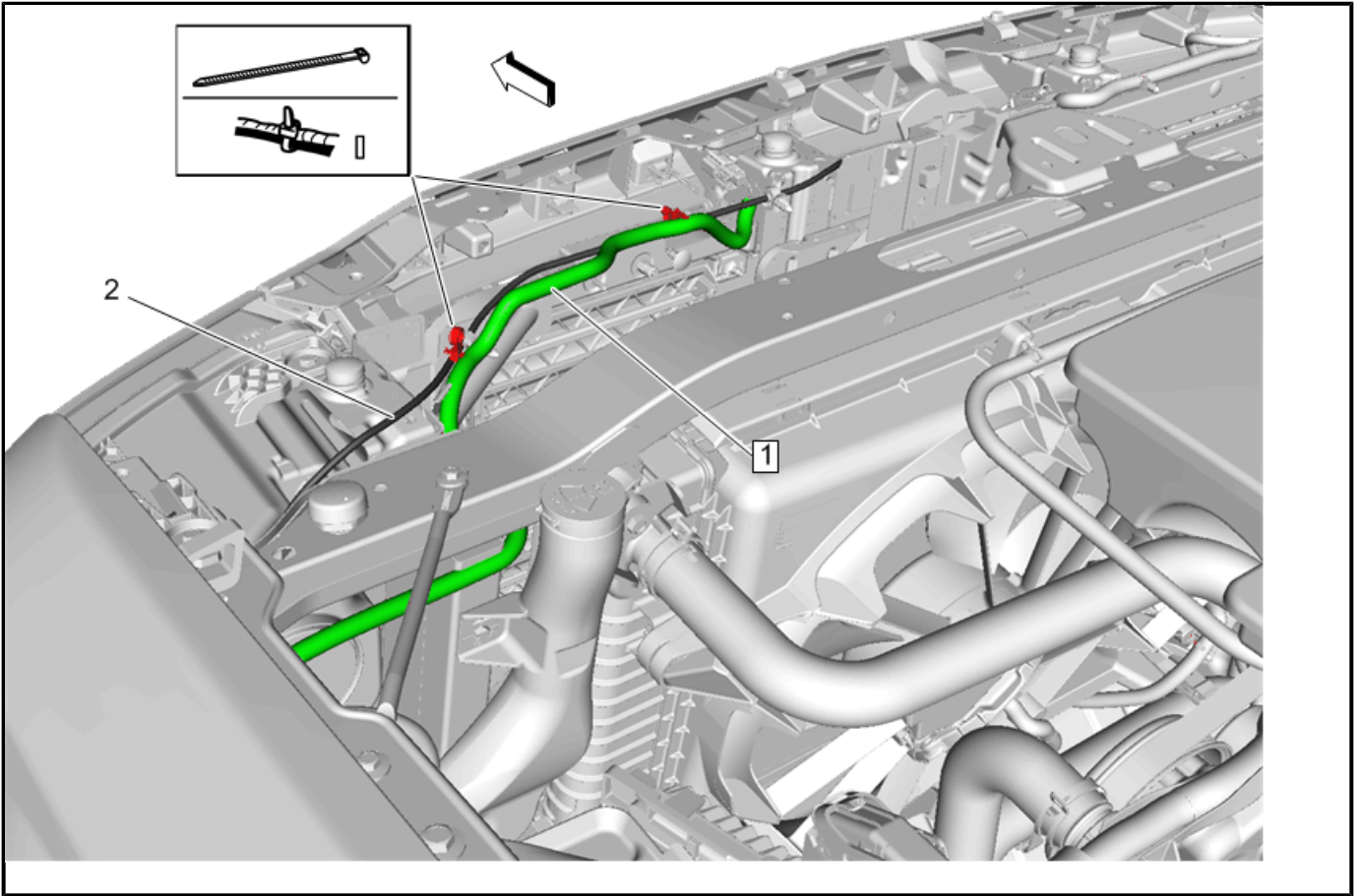

4436483

16. Secure harness (1) to hood release cable (2) using tie straps.

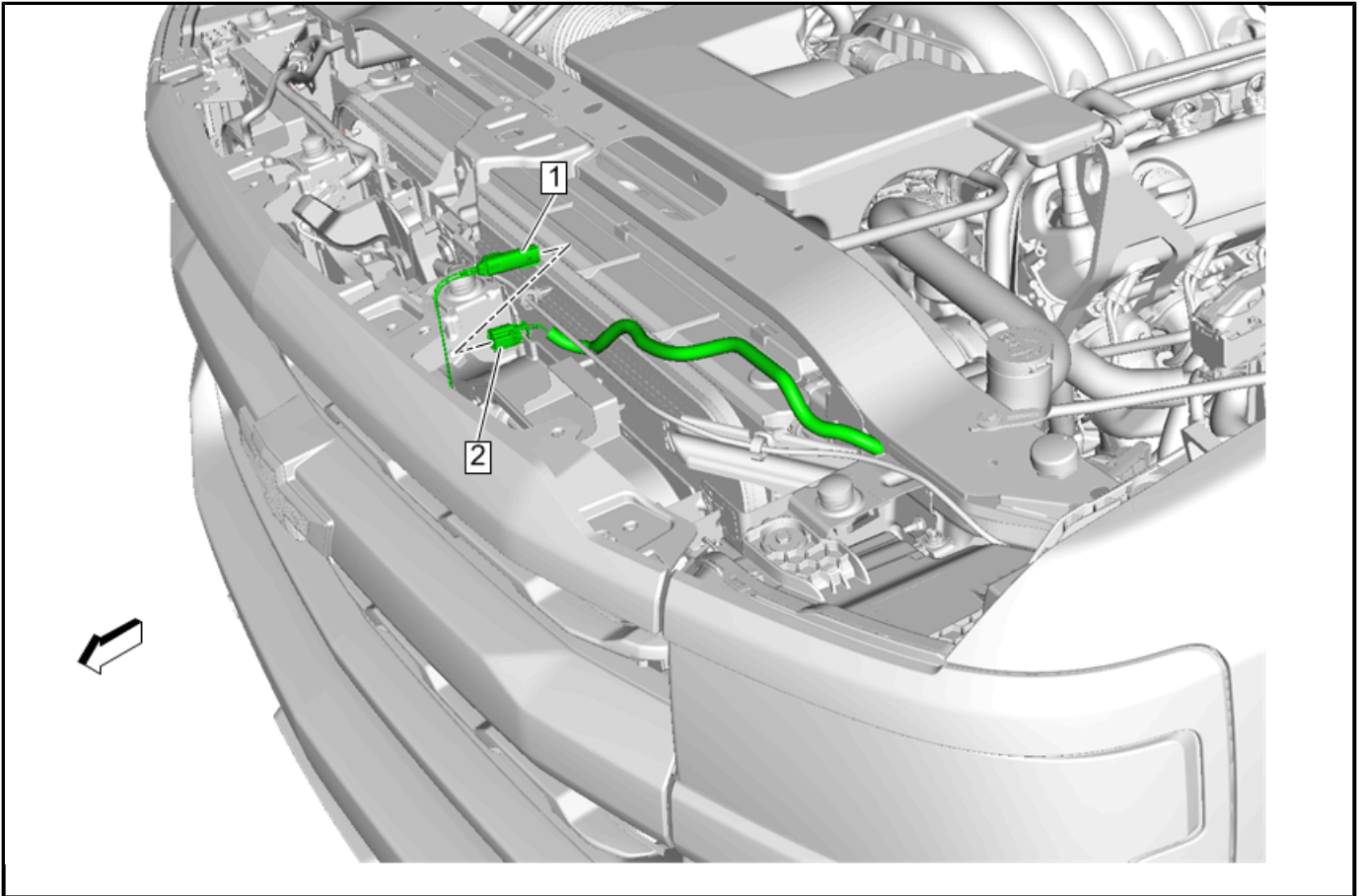

4436487

17. Connect the accessory harness (2) to the illuminated emblem (1).

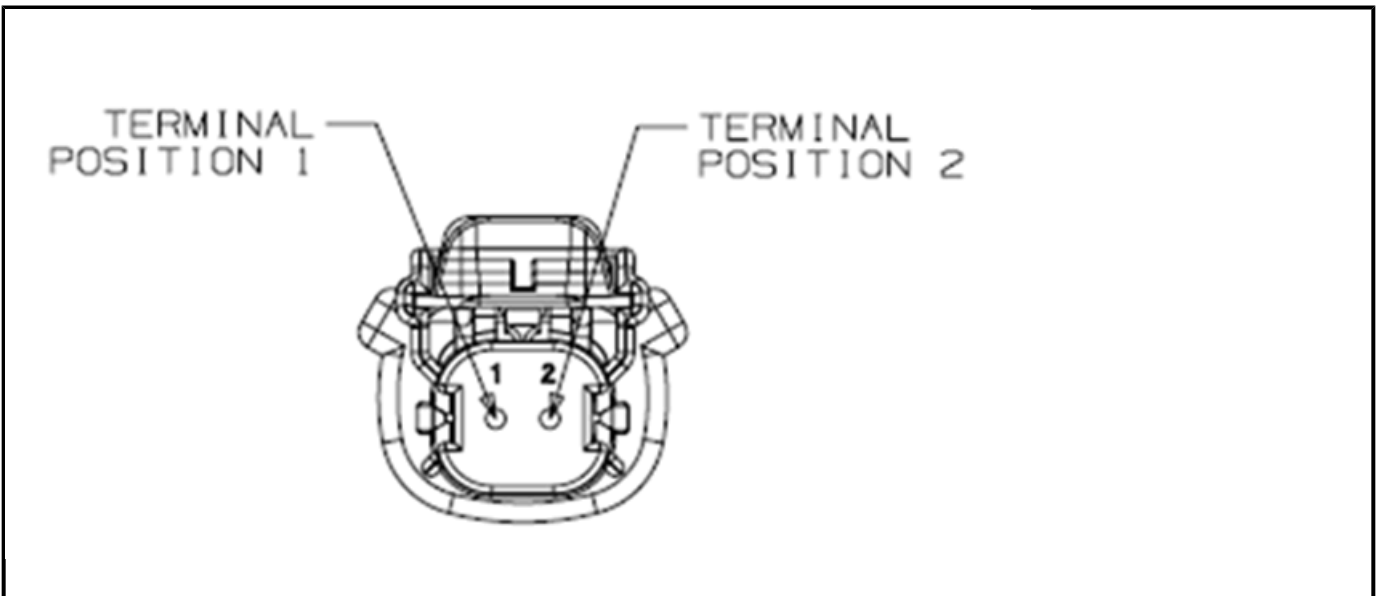

4620134

**Note:** WHITE wire goes in Cavity 1 and BLACK wire into Cavity 2 (on the harness side the wire is PURPLE or VIOLET).

18. Install the front upper grille.
19. Install the front compartment front sight shield.
20. Check headlamp functions.

## Rear Bow Tie Emblem Replacement

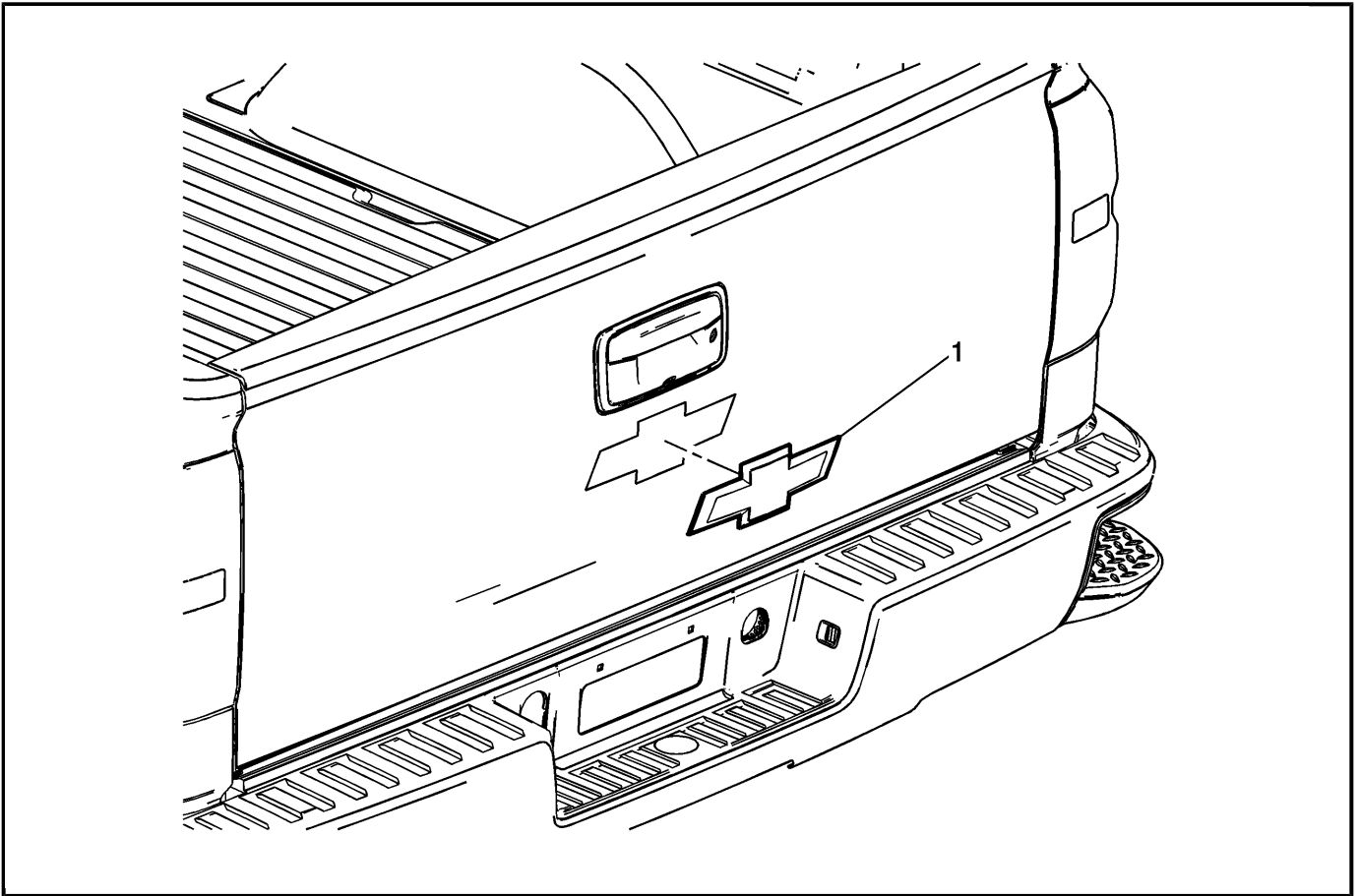

3264034

1. Mark position of production emblem with a washable marker or masking tape prior to removal.
2. The part surface should be 21°C (70°F) prior to installation. The vehicle should remain 21°C (70°F) for one hour after assembly to allow adhesive to develop sufficient bond strength.
3. Use a heat gun or equivalent to remove the liftgate emblem. Use a plastic flat bladed tool to assist in removal.
4. Clean any remaining residue with included solvent wipe or with a 50/50 mixture by volume of isopropyl alcohol and clean drinkable water. Wipe surface dry with a clean lint free towel.
5. When removing protective liners from the adhesive tape, be careful no to touch tape with hands and do not allow tape to come in contact with dirt or any foreign matter prior to adhesion.
6. Position new black emblem (1) carefully within reference marks and place on prepared surface.
7. Using the palm of the hand, wet out the emblem to ensure full adhesion is achieved.