

Document ID: 3994395

Front Grille Kit Installation

Installation Instructions Part Number

23463568

Kit Contents

Qty	Description
1	Upper Grille
1	Installation Instructions

Procedure

Caution: Use the correct fastener in the correct location. Replacement fasteners must be the correct part number for that application. Fasteners requiring replacement or fasteners requiring the use of thread locking compound or sealant are identified in the service procedure. Do not use paints, lubricants, or corrosion inhibitors on fasteners or fastener joint surfaces unless specified. These coatings affect fastener torque and joint clamping force and may damage the fastener. Use the correct tightening sequence and specifications when installing fasteners in order to avoid damage to parts and systems.

1. Remove the fasteners connecting the front wheelhouse liners to the front bumper fascia. Refer to [Front Wheelhouse Liner Replacement - Right Side](#) and [Front Wheelhouse Liner Replacement - Left Side](#).
2. Disconnect the retainers connecting the front wheel opening molding to the front bumper fascia. Refer to [Front Wheel Opening Molding Replacement](#).
3. Remove the fasteners connecting the underbody front air deflector to the front bumper fascia. Refer to [Underbody Front Air Deflector Replacement](#).

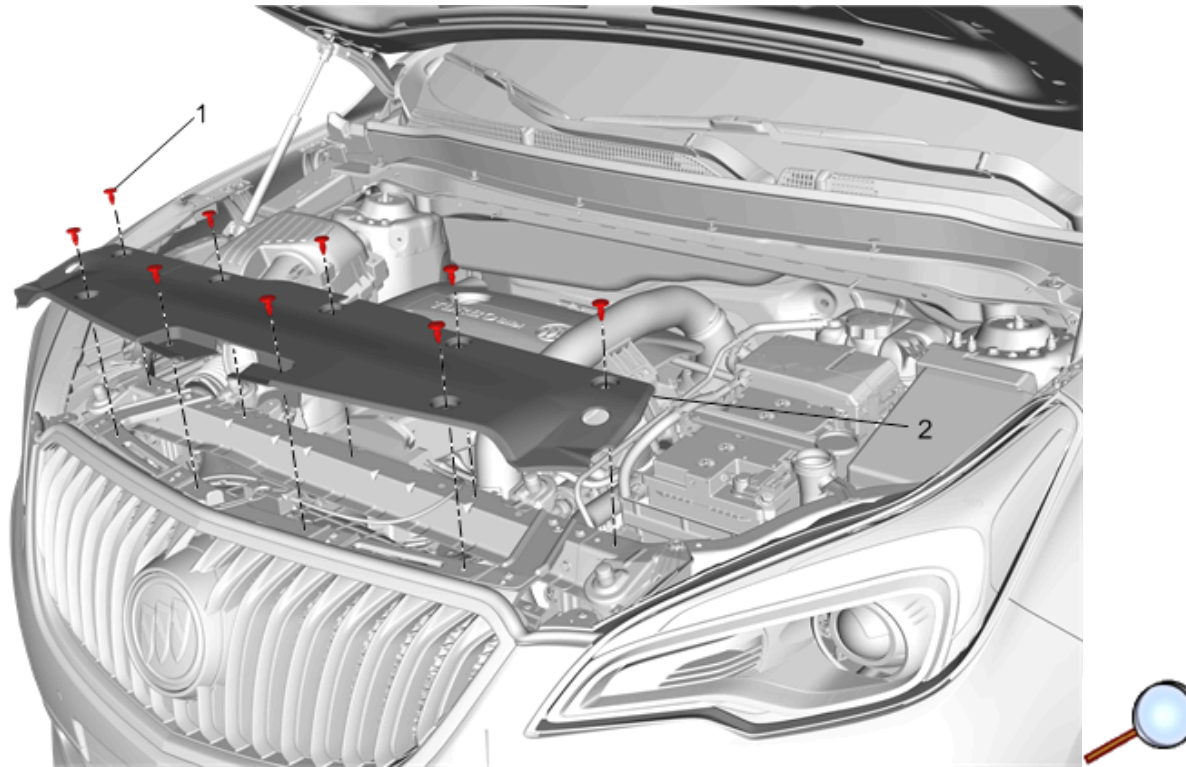

4. Open the hood and remove the nine retainers (1) securing the front compartment front sight shield.
5. Remove the front compartment front sight shield (2) from vehicle.

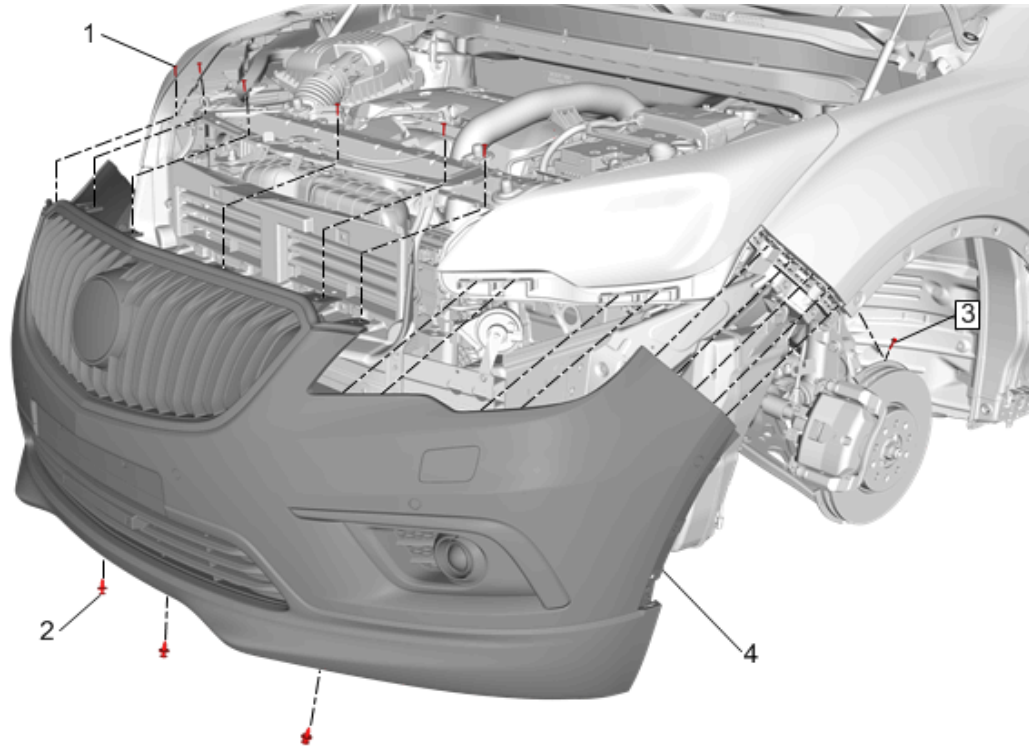

6. Remove the six upper bolts (1) from the front bumper fascia (2).
Upon reassembly tighten the upper bolts to 2.5 N.m (22 lb in).
7. Carefully push a small nylon wedge between the fascia and the front fascia guide. Insert a small flat-bladed tool into the fascia slot and depress the snaps one at a time and pull on the fascia at the same time to gradually remove the fascia from the front fascia guide.
8. Disconnect the electrical connectors and washer pump hose from front bumper fascia.

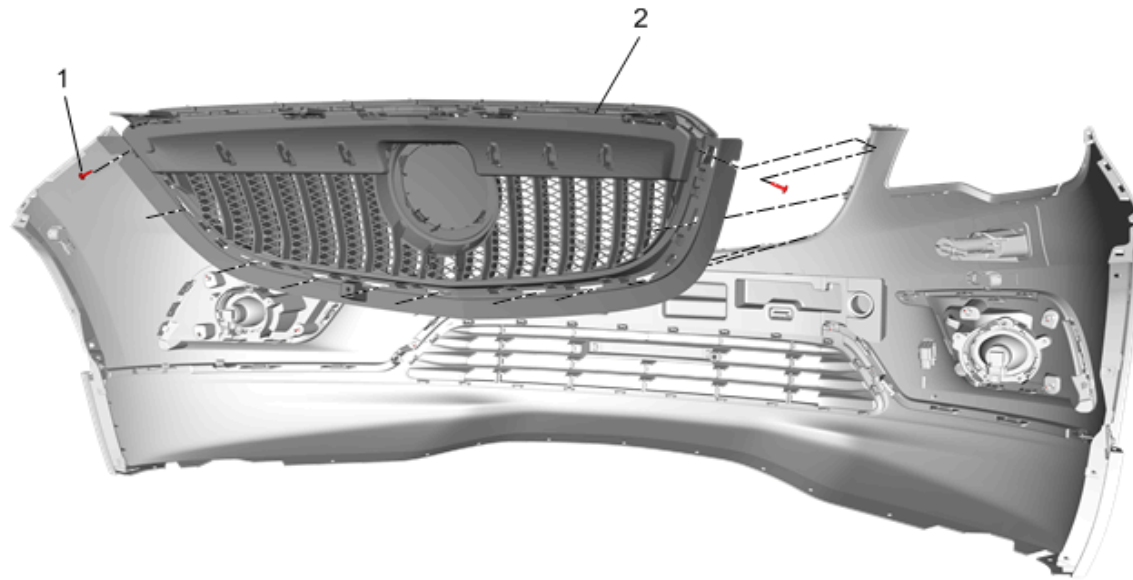

9. Remove the two bolts (1) securing the factory installed front upper grille (2) to the front bumper fascia.
10. Place the front bumper fascia down on a clean protected surface.
11. Using a suitable trim tool, release the locking tabs while carefully pulling the front upper grille from the front bumper fascia.

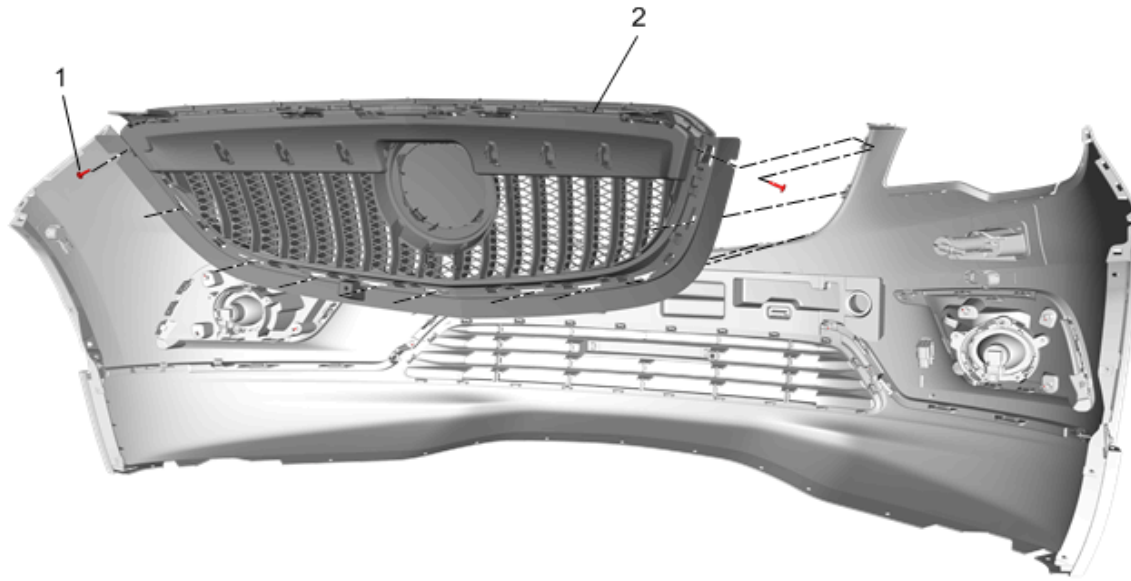

Note: Each individual front bumper fascia tab must be secure to each slot in the front upper grille prior to reassembly of the front bumper fascia to the vehicle.

12. Install the accessory front upper grille (2) to the front bumper fascia while securing all locking tabs.
13. Install the two previously removed bolts (1) to the front upper grille.
Tighten the bolts to 2.5 N.m (22 lb in).
14. Reinstall front bumper fascia and previously removed components.