

Document ID: 4535378

Rear Bumper Fascia Protector Package Installation

Installation Instructions Part Number

84018891

Kit Contents

Qty	Description
1	Rear Bumper Protector
1	Rear Bumper Protector Template – Driver and Passenger Side
1	Installation Instructions

Tools Required

Isopropyl Alcohol

Clean Lint Free Towel

Rubber Roller

Procedure

Note: When servicing part, remove the rear bumper protector using a heat gun or equivalent. Use a plastic flat bladed tool to assist in removal.

Note: Apply the rear bumper protector in an environment free of dust and dirt. Dust and dirt could come in contact with the adhesive surface and prevent proper adhesion.

1. The part and surface should be 21°C (70°F) prior to installation. The vehicle should remain 21°C (70°F) for one hour after assembly to allow adhesive to develop sufficient bond strength.
2. Clean any remaining residue with a 50/50 mixture by volume of isopropyl alcohol and clean distilled water. Wipe the surface dry with a clean lint free towel.

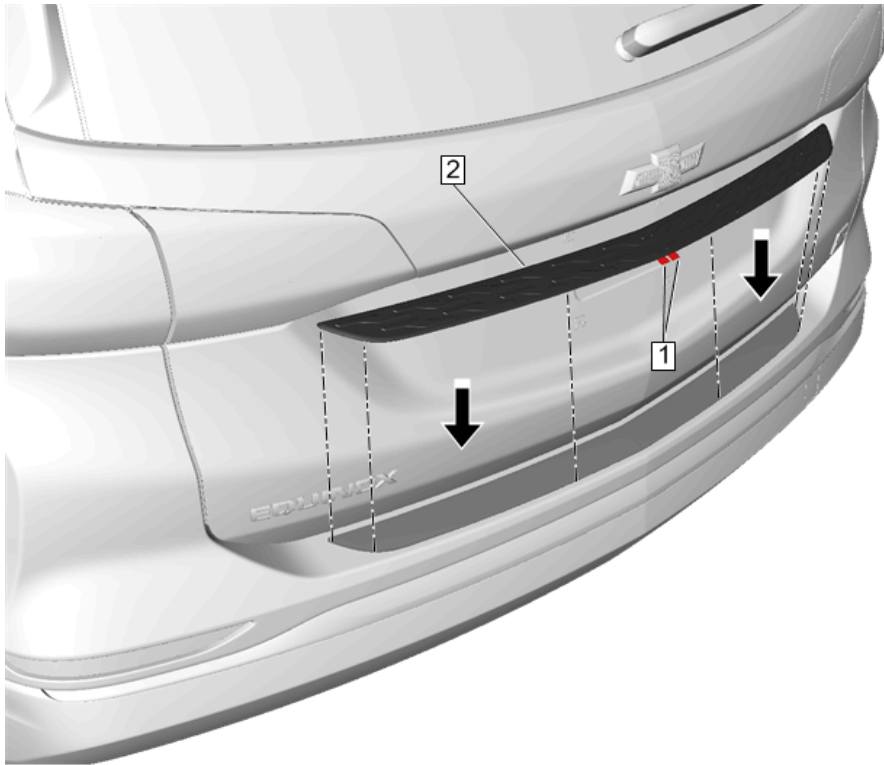

3. Align installation templates, driver and passenger-sides, on the rear fascia. Tape templates in place where indicated on templates. Verify correct placement of installation templates, by aligning the rear bumper protector on the fascia.
4. Peel back tape liner (1) only 2 inches on either side of the rear bumper protector (2) at the center of the part.
Note: When removing protective liners from the adhesive tape, be careful not to touch the tape with hands and do not allow tape to come in contact with dirt or any foreign matter prior to adhesion.
5. Align rear bumper protector (2) to the driver-side template. Repeat with the passenger-side template.
Note: Be careful not to press down in the center of the part while aligning the part to either end of the vehicle with the respective templates.

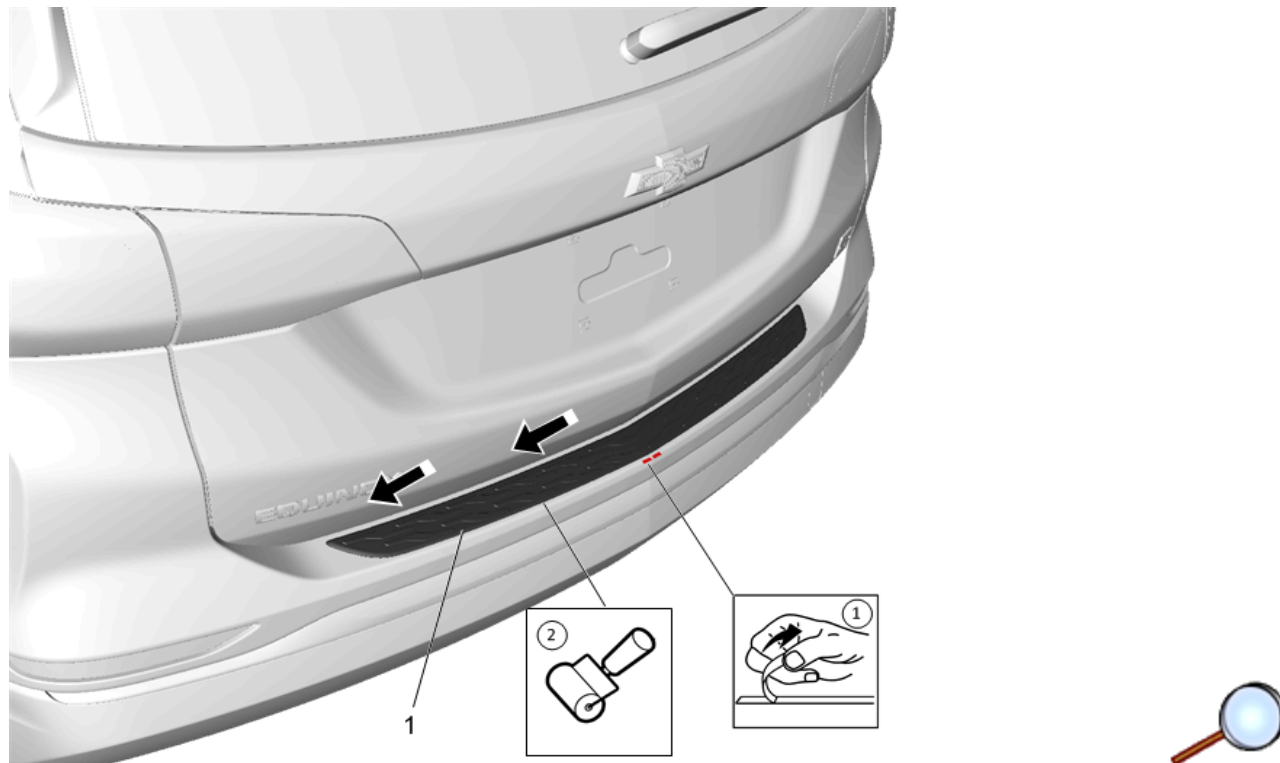

6. Once the rear bumper protector (1) is aligned on the rear fascia, press down in the center of the part.
7. On the driver-side of the rear bumper protector, slowly peel back tape liner, pressing down on part as the tape liner is removed.

Note: Do not press down hard, as the edge of the part may rip the tape liner.
8. Repeat Step 7 for the passenger-side of the rear bumper protector.
9. In order to ensure that the tape sees 100% surface contact to the surface of the vehicle, apply consistent, uniform pressure starting from the center of the rear bumper protector and moving outward towards the driver-side of the vehicle. Repeat for passenger-side of the vehicle. Use a roller if available and / or by hand.
10. Repeat Step 9 for the passenger-side of the rear bumper protector.
11. Remove installation templates.