

Document ID: 4587337

Rocker Panel Protector Package Installation

Installation Instructions Part Number

84114572

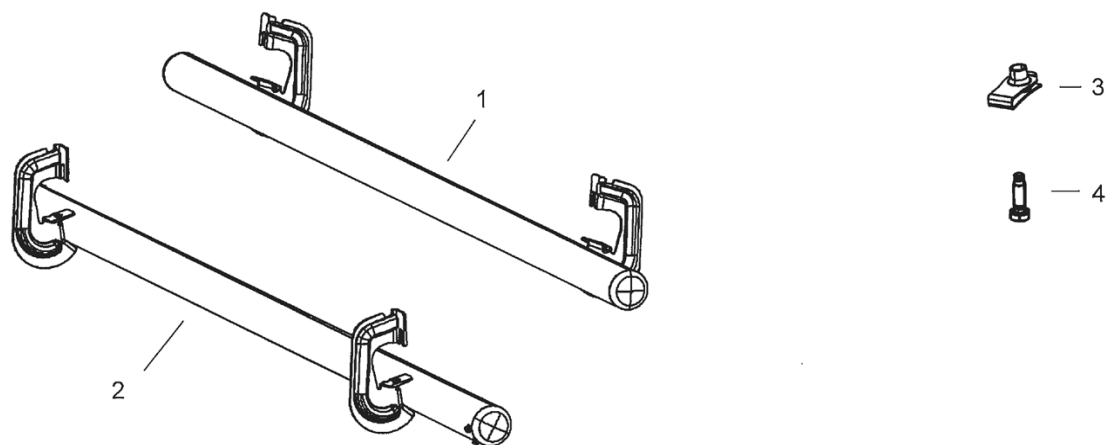

Kit Contents

| Item | Description | Qty Extended Cab: | Qty Crew Cab: |
|------|---------------------------------|-------------------|---------------|
| 1 | Rocker Protector Driver Side | 1 | 1 |
| 2 | Rocker Protector Passenger Side | 1 | 1 |
| 3 | M8 U-Nut | 8 (Gas) | 8 (Gas) |

© 2018 General Motors. All rights reserved.

| Item | Description | Qty Extended Cab: | Qty Crew Cab: |
|------|-------------------|-------------------|---------------|
| 4 | M8 Bolt | 8 (Gas) | 8 (Gas) |
| 5 | Instruction Sheet | 1 | |

Torque Table

8mm Hardware torque to 25N•m (18 lb ft)

Tools Required

- Torque Wrench
- 13mm Socket
- 3/8" drive Ratchet
- 3" 3/8" drive extension

Procedure

Note: Read entire instruction sheet thoroughly before starting.

Note: Left hand and right hand assemblies are identified on the bottom side of each end of the tube.

Caution: Use the correct fastener in the correct location. Replacement fasteners must be the correct part number for that application. Fasteners requiring replacement or fasteners requiring the use of thread locking compound or sealant are identified in the service procedure. Do not use paints, lubricants, or corrosion inhibitors on fasteners or fastener joint surfaces unless specified. These coatings affect fastener torque and joint clamping force and may damage the fastener. Use the correct tightening sequence and specifications when installing fasteners in order to avoid damage to parts and systems.

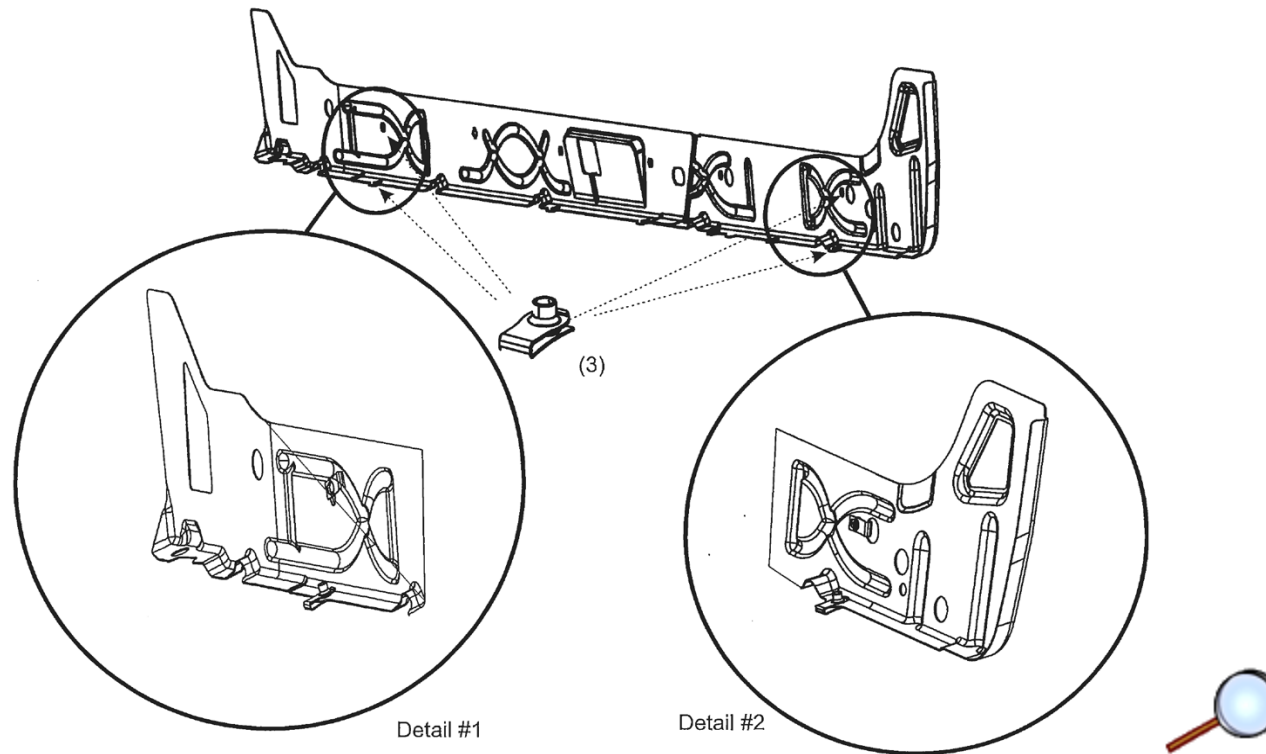

1. Install U-nuts (1) (Item 3) onto existing holes in pinch flange and inner rocker panel. Refer to graphic (detail #1 and 2) for locations and orientation of U-nuts (1). Install U-nuts (1) with the threads up on pinch flange and with threads inside of the inner rocker panel. On some vehicles it may be necessary to remove and discard hole plugs to install the U-nuts.

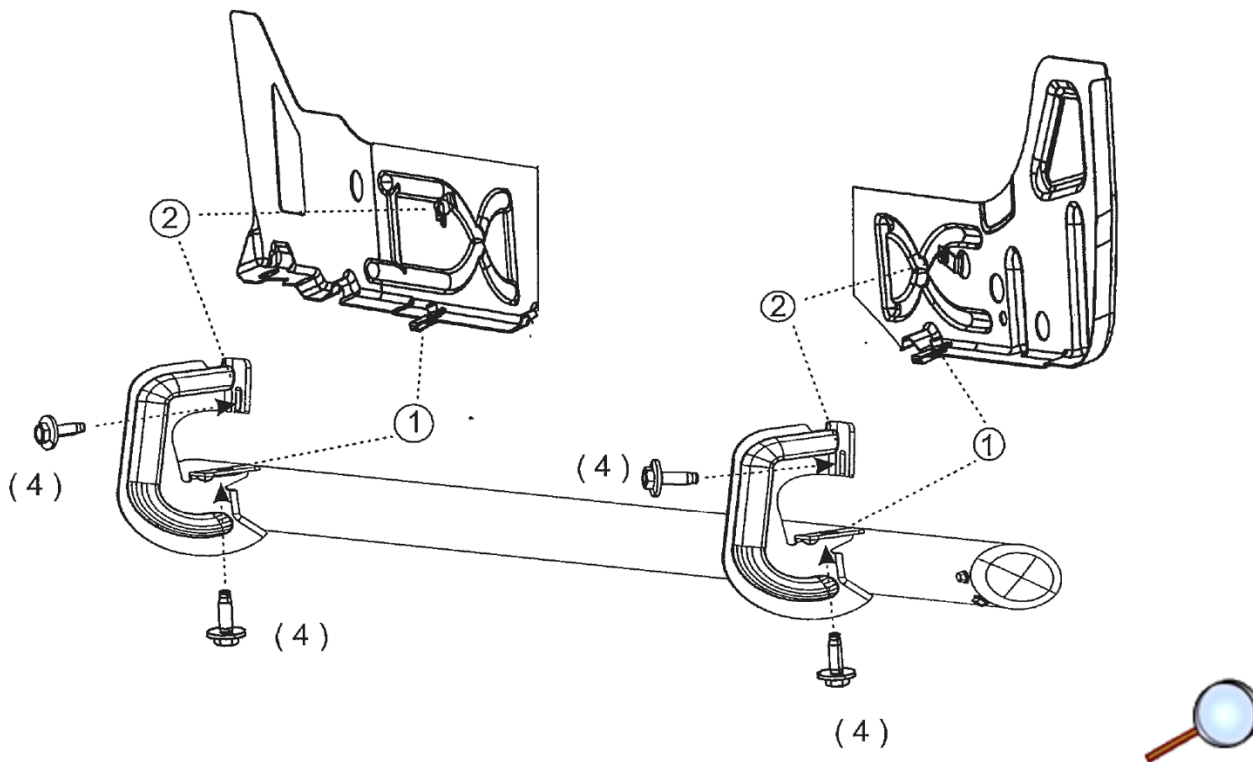

2. Position the left side rocker protector to the inner rocker panel and secure by hanging front bracket in upper slot with loosely installed M8 bolt (4). Then hang the rear bracket on loosely install M8 bolt (4).
3. From underneath, loosely insert M8 bolt (4) through bracket, rocker panel, and into U-nut (Item 3) in upper rocker panel position (2).
4. Loosely insert M8 bolt (4) through bracket and into U-nut (3) in upper rocker panel position (2).
5. Tighten the M8 bolts (4) in lower positions to 25 N.m (18 lb ft).
6. Repeat step 5 for the upper positions. Tighten the bolts to 25 N.m (18 lb ft).
7. Repeat steps 1 through 6 for passenger side rocker protector assembly.

8. Verify correct torque on all fasteners.

