

Document ID: 4522391

Front Tow Hook Package Installation

Installation Instructions Part Number

84126892

Tow Hook Replacement (2016 and Beyond) Chevy and GMC Crew Cab With Existing Tow Hooks

Removal

1. Raise and support vehicle.
2. Driver Tow Hook
 - 2.1. Loosen tow hook through bolt and remove bolt out of frame rail enough to allow clearance for bolt head to be cut (qty 1).
 - 2.2. Cut bolt head off and remove bolt out of the outboard side of frame rail.
 - 2.3. Remove the rear tow hook bolt and remove the OE tow hook (qty 1).
3. Passenger Side Tow Hook
 - 3.1. Remove tow hook bolts (qty 2)/nut (qty 1).
 - 3.2. **Note:** Passenger side tow hook bolts should not need to be cut.
4. Swap rubber guard/seal from OE tow hooks to replacement tow hooks.

Installation

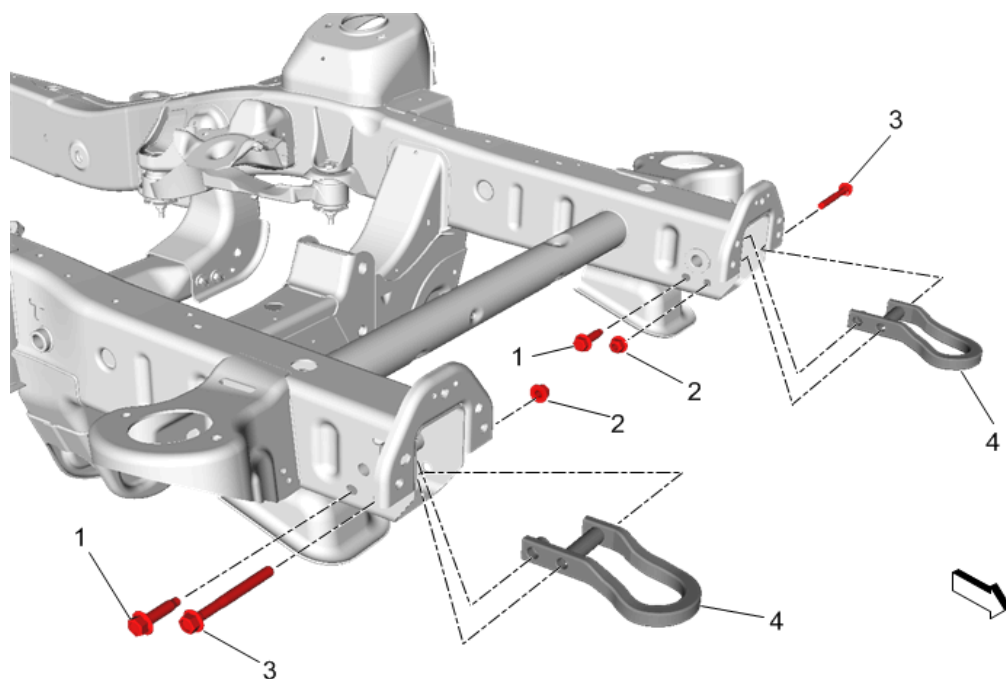

Caution: Use the correct fastener in the correct location. Replacement fasteners must be the correct part number for that application. Fasteners requiring replacement or fasteners requiring the use of thread locking compound or sealant are identified in the service procedure. Do not use paints, lubricants, or corrosion inhibitors on fasteners or fastener joint surfaces unless specified. These coatings affect fastener torque and joint clamping force and may damage the fastener. Use the correct tightening sequence and specifications when installing fasteners in order to avoid damage to parts and systems.

1. Install new tow hooks (4) to frame rail (nut-qty 1 and bolt-qty 2 per hook) making sure that the through bolt head is facing outboard of the frame rail.
2. Install the through bolt (3) and nut (2) and tighten to **80 N.m (59 lb ft)**.
3. Install the short bolt (1) to frame and tighten to **80 N.m (59 lb ft)**.
4. Lower vehicle.

[Tow Hook Replacement All Other Chevy and All GMC \(2016 and Beyond\)](#)

Prep Vehicle

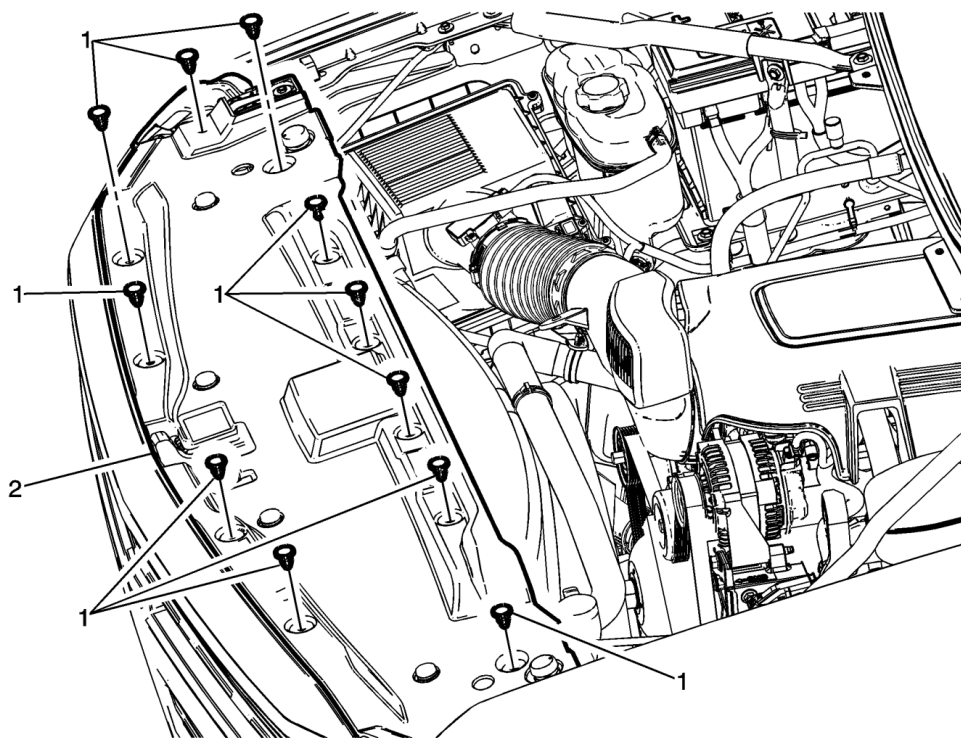

1. Remove compartment front sight shield push-in retainers (1), (qty 12) and remove sight shield (2).
2. Remove upper grille bolts (qty 4).
3. Loosen wheel liner fasteners and wheel lip moldings to access the front bumper brackets (GMC ONLY).
4. Partially raise and support vehicle.
5. Remove bumper fascia trim cap bolts (qty 2) (GMC ONLY).
6. Loosen the bumper fascia side brackets (qty 3 per side) (GMC ONLY).
7. Use trim stick into trim cap slot and depress snaps one at a time and pull on the front bumper fascia trim cap (GMC ONLY).
8. Lower the vehicle.
9. Remove lower grille bolts (qty 4) (GMC only).
10. Starting at driver side, with 2 hands, firmly pull along grille to remove the 8 spring clips from the shutter body (4 spring clips for GMC).
11. Partially raise and support vehicle.
12. Remove bumper impact bar bolts (qty 4).
13. Disconnect fog lamp harness connector and remove the 1st retainer.

14. Bumper pencil brace bolts: Loosen outboard (qty 2), remove inboard (qty 4).
15. Remove front bumper.
16. Remove tow hook bolts/nuts and tow hooks (qty 2).
17. Swap rubber guard/seal from OE tow hooks to replacement tow hooks.

Installation

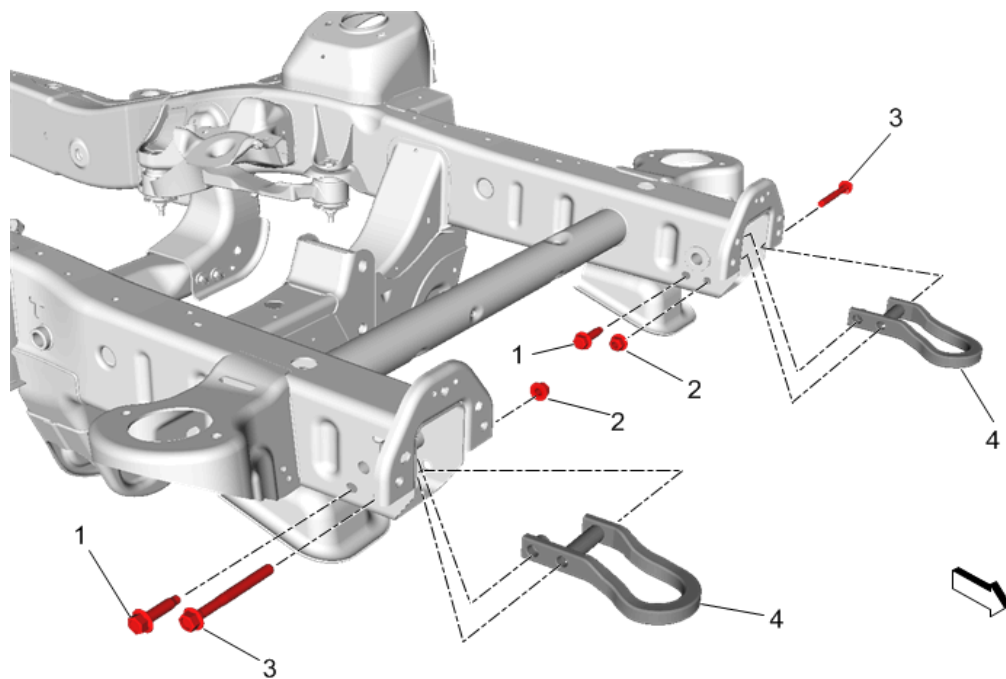

Caution: Use the correct fastener in the correct location. Replacement fasteners must be the correct part number for that application. Fasteners requiring replacement or fasteners requiring the use of thread locking compound or sealant are identified in the service procedure. Do not use paints, lubricants, or corrosion inhibitors on fasteners or fastener joint surfaces unless specified. These coatings affect fastener torque and joint clamping force and may damage the fastener. Use the correct tightening sequence and specifications when installing fasteners in order to avoid damage to parts and systems.

1. Install new tow hooks (4) to frame rail (nut-qty 1 and bolts-qty 2 per hook).
2. Install the through bolt (3) and nut (2) and tighten to **80 N.m (59 lb ft)**.
3. Install the short bolt (1) to frame and tighten to **80 N.m (59 lb ft)**.
4. Install/tighten impact bar bolts to **100 N.m (74 lb ft)**. and pencil brace bolts to **80 N.m (59 lb ft)**.

5. Connect fog lamp harness and 1st retainer.
6. Lower vehicle.
7. Install grille bolts and tighten to **7 N.m (5 lb ft)**.
8. Partially raise and support vehicle.
9. Install front bumper fascia trim cap (bolts - qty 6) and side brackets (GMC ONLY).
10. Install wheel lip moldings and wheel liner (GMC ONLY).
11. Lower vehicle.

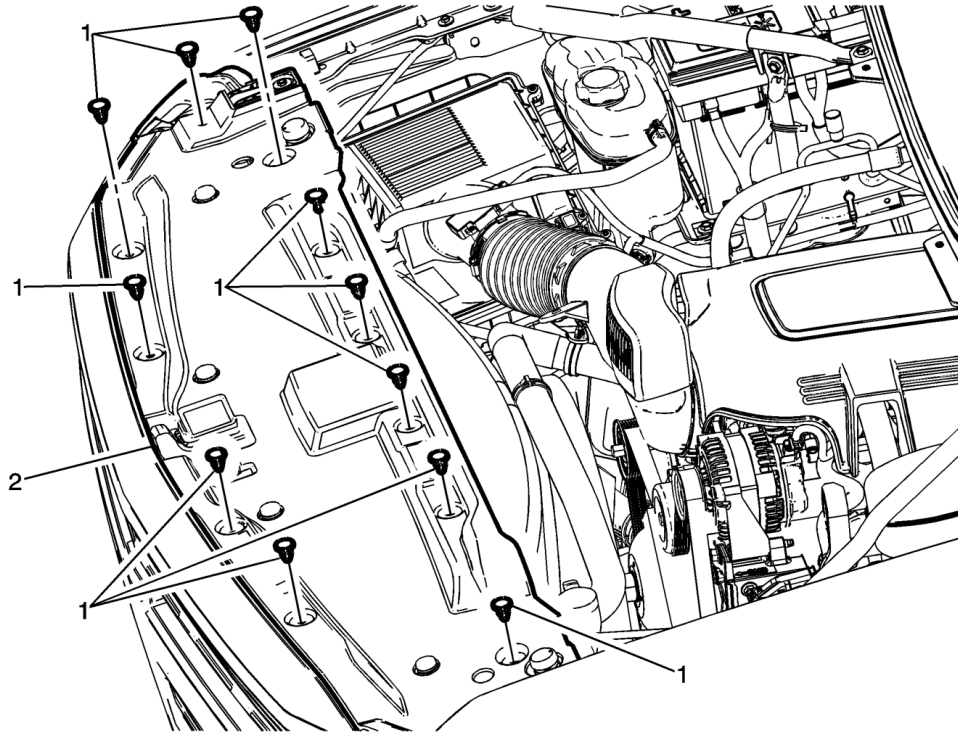

12. Install compartment front sight shield (2) and push-in retainers (1), (qty 12).

Tow Hook Installation Chevy (2014 and 2015)

1. For vehicles without tow hooks, follow **"Prep Vehicle"** Steps 1-15 above.



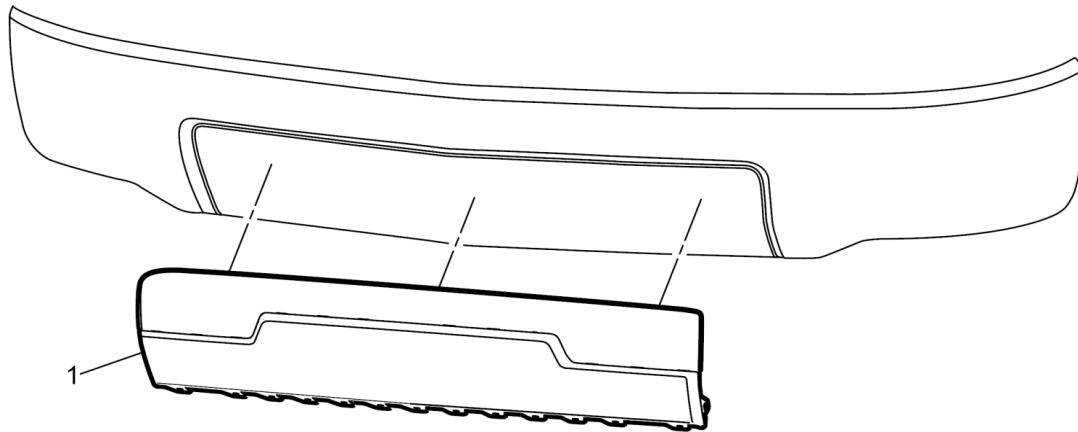

2. Remove closed fascia panel (1), P/N 23126342. Retain all hardware.

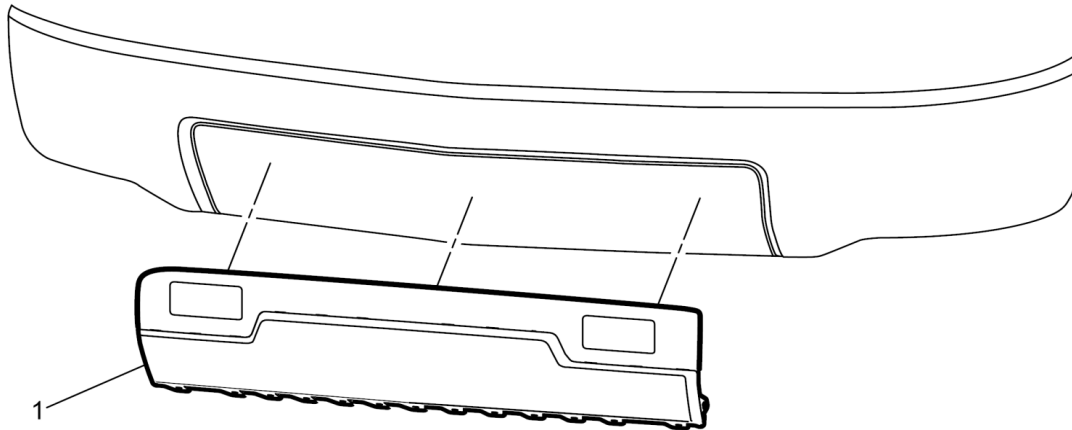

3. Install fascia panel (1), P/N 22944860 using previously retained hardware.

4. Follow "**Installation**" procedure above.

Tow Hook Installation Chevy (2016 thru 2018)

1. For vehicles without tow hooks, follow "**Prep Vehicle**" Steps 1-15 above.

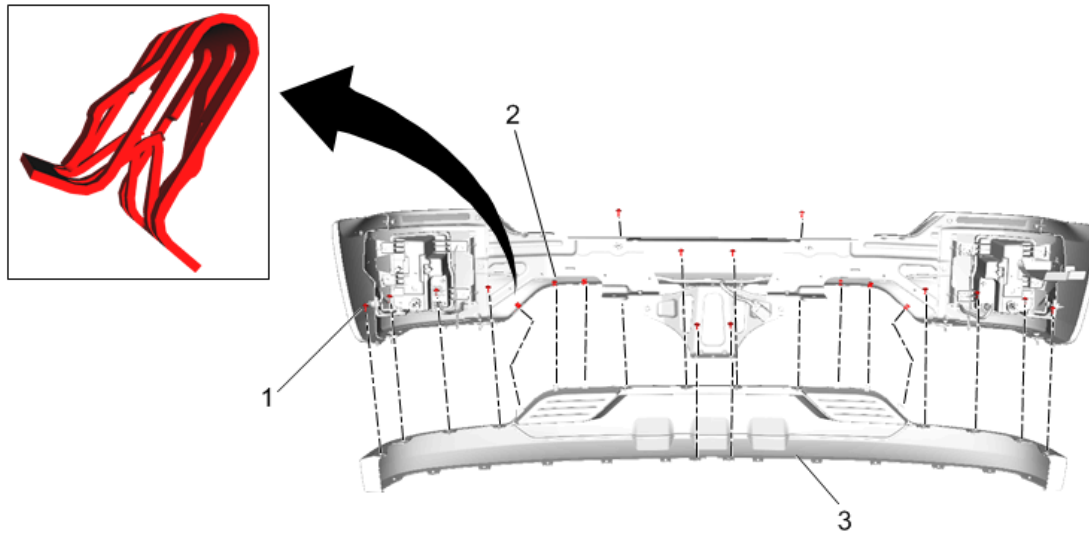

2. Remove closed fascia panel (3), P/N 84029826. Retain all hardware (1), (2).



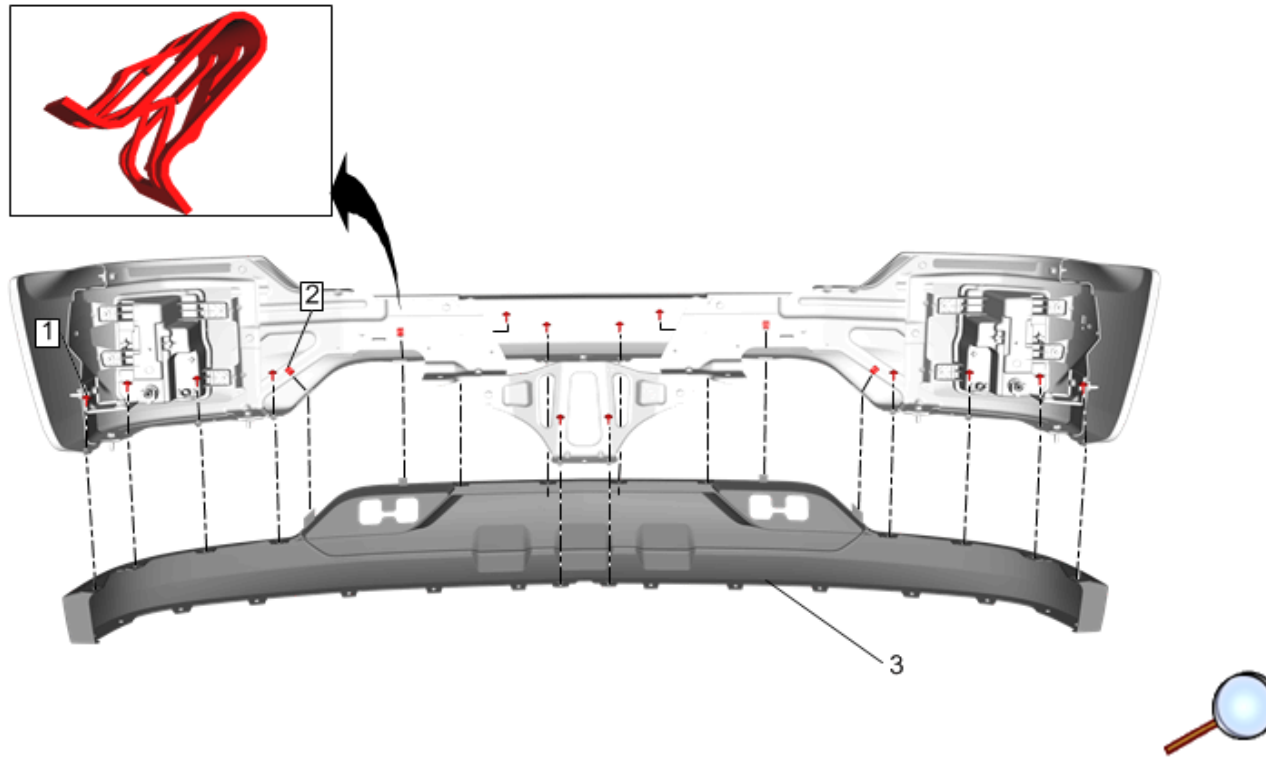

3. Install fascia panel (3), P/N 84029800 using previously retained hardware (1), (2).
Tighten
Tighten bolts to 6 N.m (53 lb in).
4. Follow "**Installation**" procedure above.

Tow Hook Installation GMC (2014 thru 2018)

1. For vehicles without tow hooks, follow "**Prep Vehicle**" Steps 1-15 above.

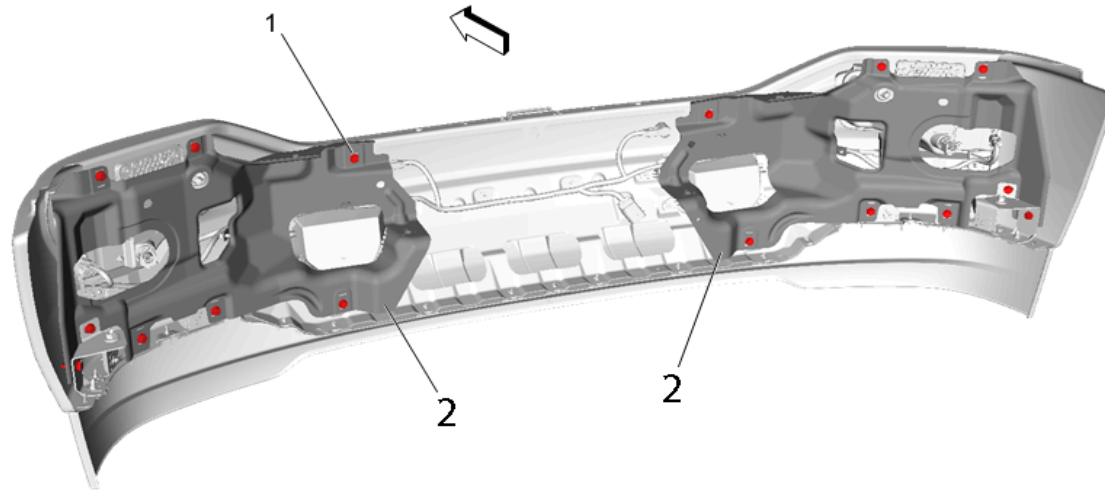

- 1.1. Remove the LH/RH bumper bracket fasteners (1), (qty 16) and brackets (2). Upon Reassembly tighten fasteners to 58 N.m (43 lb ft).
Disconnect fog lamp connector.

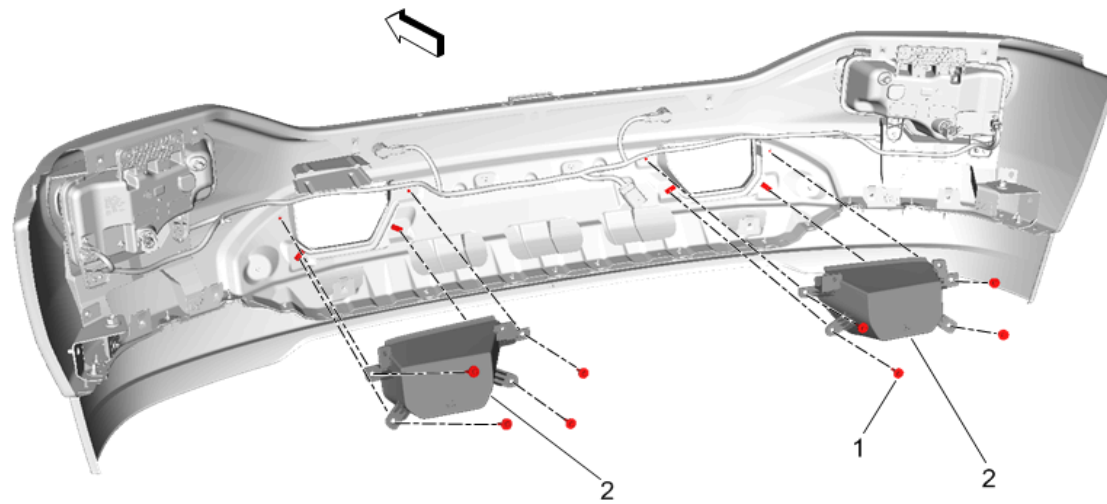

1.2. Remove tow hook delete cover fasteners (1) (qty 8).

1.3. Remove tow hook delete covers (2).

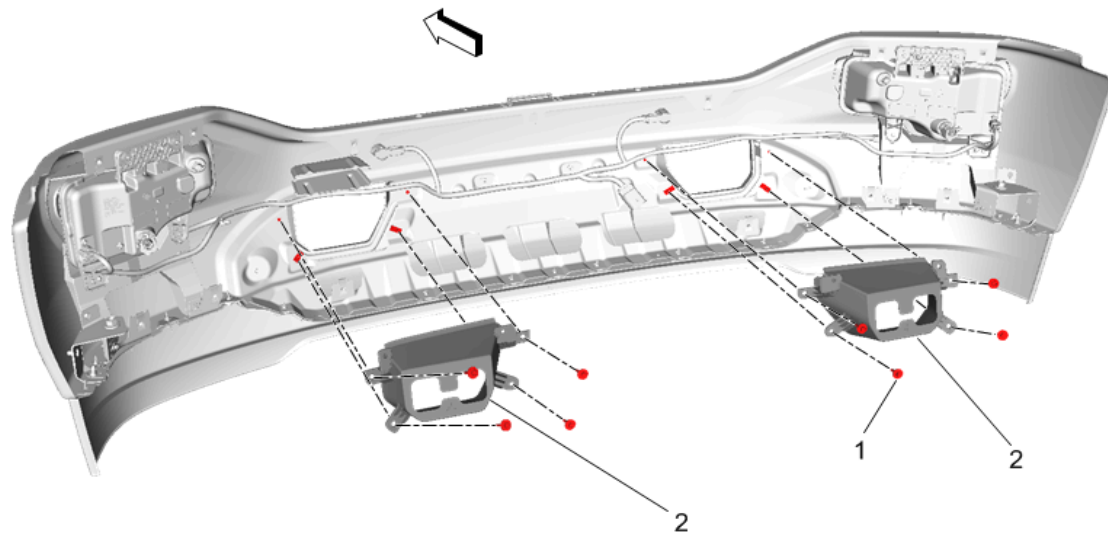

2. Install front tow hook covers (2), P/N 23243484 and 23243485 using retained hardware (1).

Tighten

Tighten to 6 N.m (53 lb in).

3. Follow "**Installation**" procedure above.