

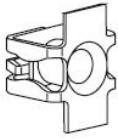





Soft Roll-Up Tonneau

Installation Parts Includes:

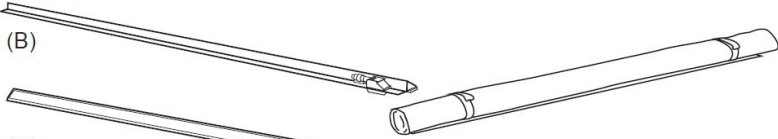
Drill Guide  x2	Box Nuts  x4	Backing Plates  x8	Bolts  x12	Passenger Side Rail x1  Driver Side Rail x1  Roll-Up Tonneau Cover x1 
--	---	---	---	--

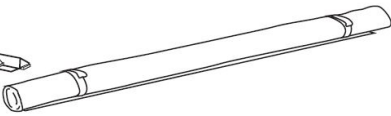
Tools Required:

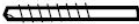
T30 Torx 	Drill 	7.0mm (9/32") drill bit 
---	--	--

Preparations:

- Identify truck bed attachment points (Step 1)
- Drill plastic rail cap at attachment points (Step 3 and Step 4)

Installation Instructions:

Read all instructions before proceeding. It is recommended that two people install the tonneau cover.

Step 1:

Locate truck bed attachment points for driver side and passenger side rails. Attachment points are holes in truck bed sheet metal behind the plastic rail cap.

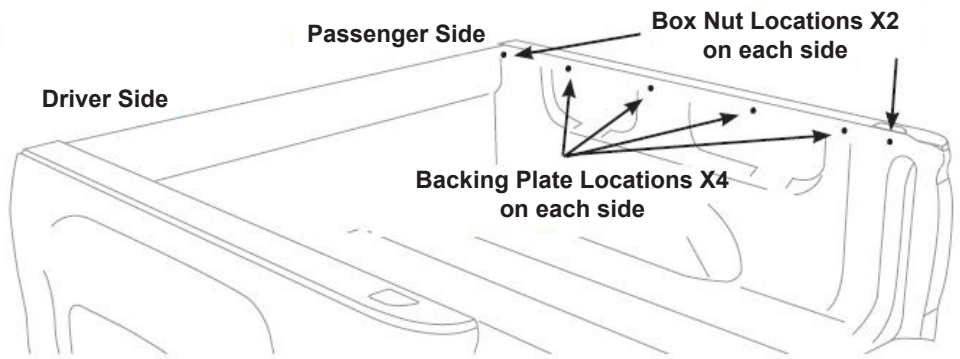

Step 2:

Install a Box Nut in each of the four (4) corner pillar positions. Box nuts are inserted in truck bed sheet metal as shown below. Access corner pillar holes by pulling back the plastic rail caps. Press box nuts in place so they are flush with the sheet metal.

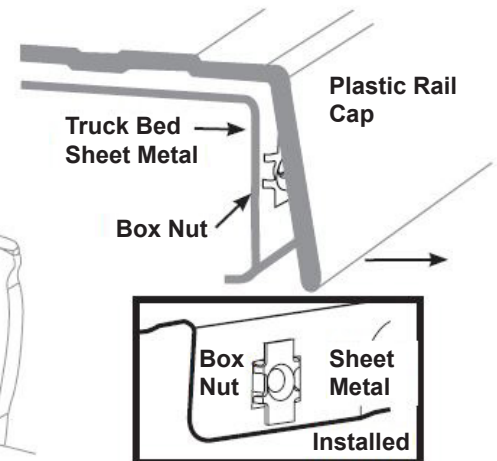
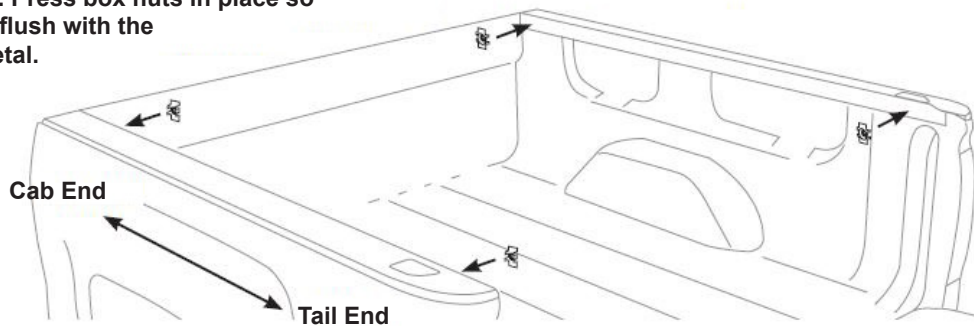

Step 3:

After installing the box nuts lift the plastic rail cap and locate the Box Nut thread inlet with the drill guide. Drill through the plastic rail cap with 7.0mm (9/32") drill bit. Repeat for all four (4) corners.

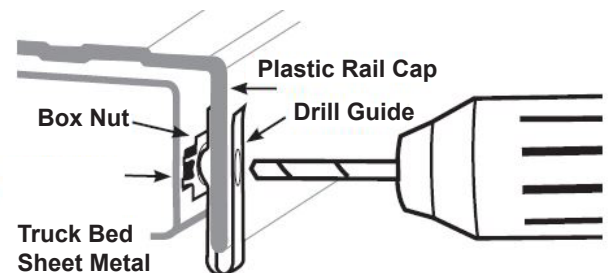

Installation Instructions:

Step 4:

Lift the plastic rail cap and locate backing plate attachment holes with the Drill Guide.
 Drill through the plastic rail cap with 7.0mm (9/32") drill bit.
 Repeat for all eight (8) backing plate locations.

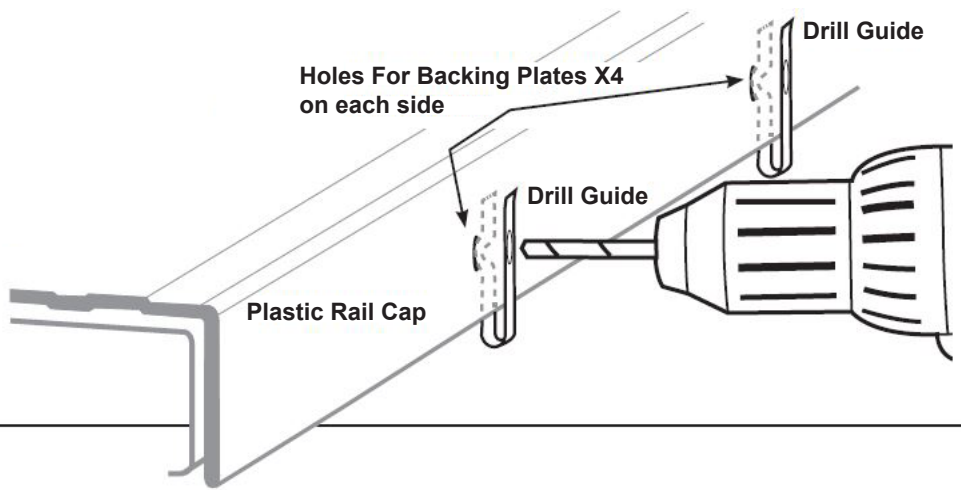

Side Rail Installation:

Step 5:

Install driver side rail (A) in the order shown. Hand-tighten attachment bolt 1 and 2 in box nuts. Hand-tighten 3, 4, 5 and 6 into backing plates. Align the edge of the rail seal with the top of the plastic trim cap as shown in figure A. Use T30 Torx to fully tighten bolts 3, 4, 5 and 6 followed by bolts 1 and 2 to 8.7 N-m. Repeat for passenger side rail (B).

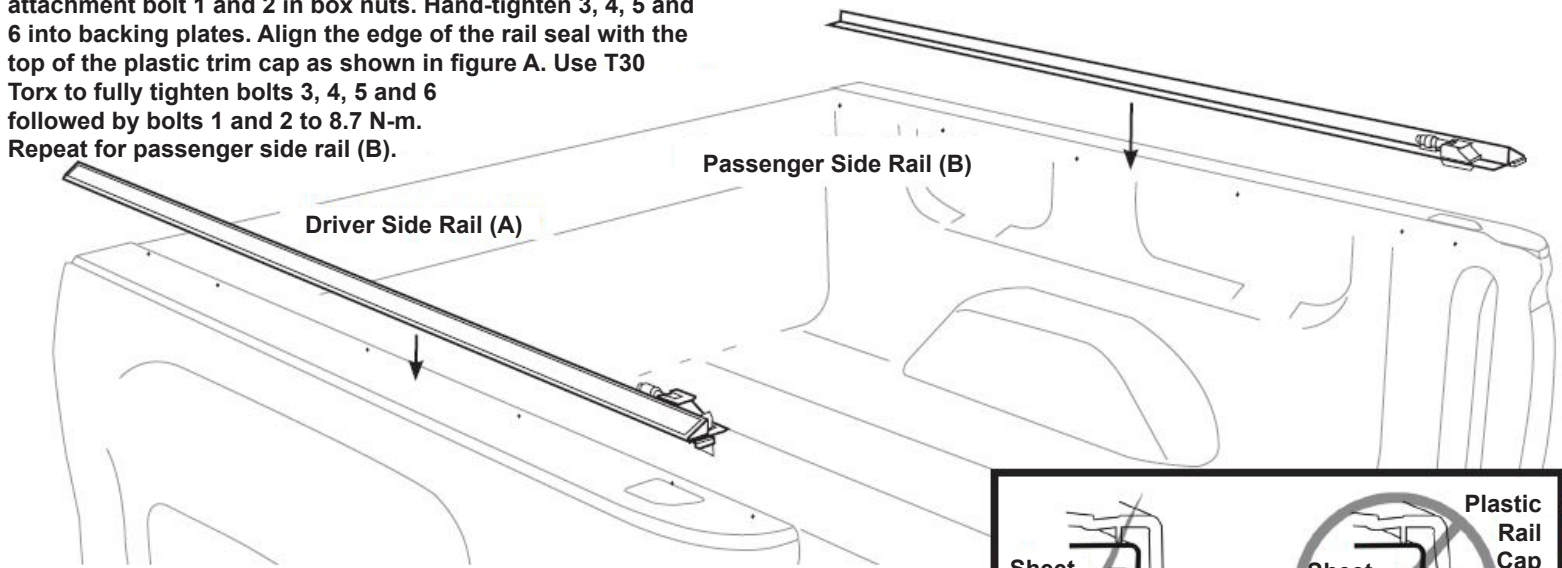

Backing plates are installed on the back side of the sheet metal. DO NOT install backing plates between plastic trim caps and sheet metal.

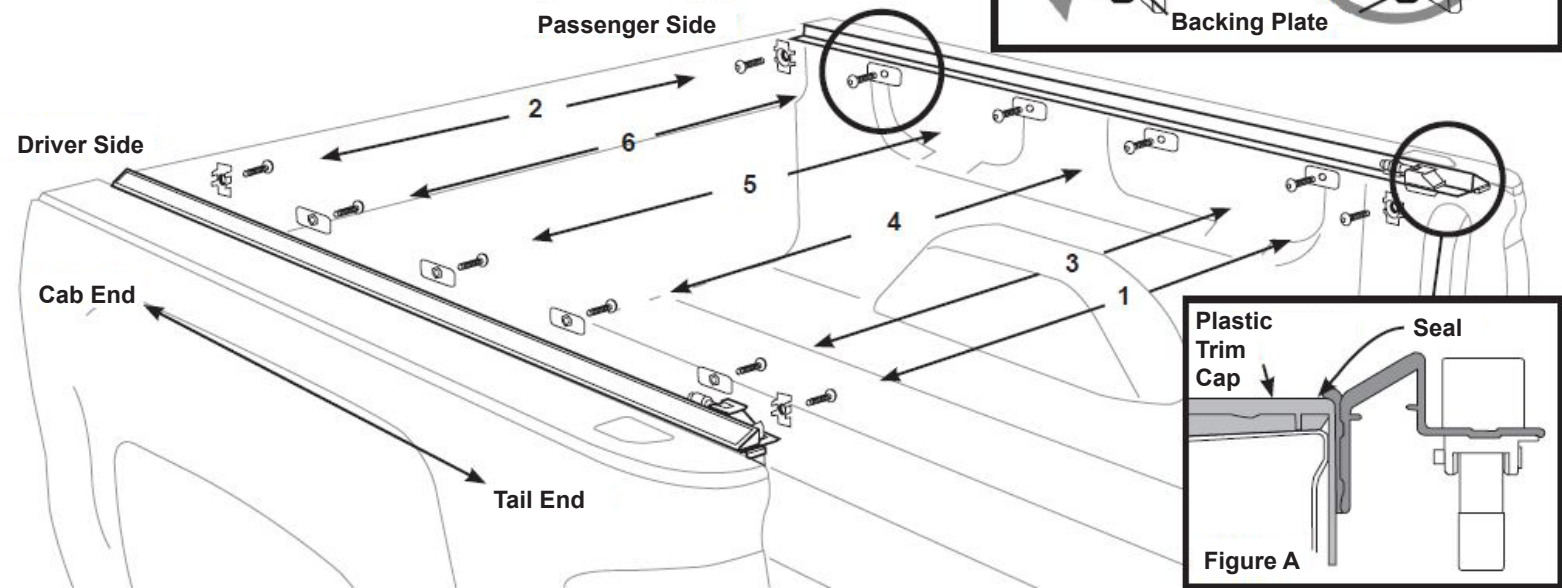
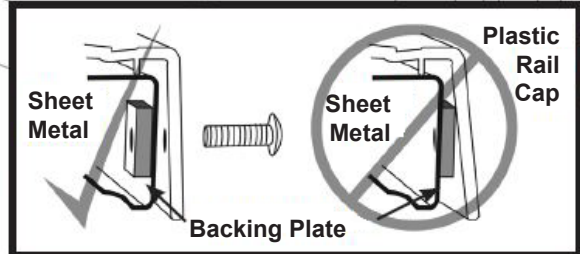

Cover Installation:

Step 6:

Remove knobs and washers from Cab Bar clamp bolt. Center Cab Bar between driver side and passenger side rails. Position Cab Bar Clamp bolts through holes in driver side and passenger side rails. Arrange Cab Seal on the top side of truck bed cab wall. Replace washer and tighten passenger side and driver side knobs to 8.7 N-m.

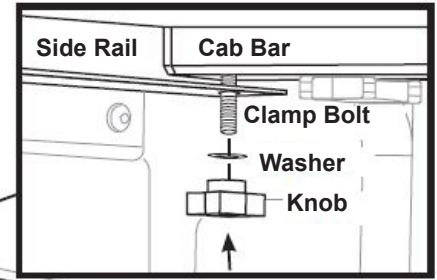

Step 7:

Unclip the tie down straps and roll out the tonneau.

Step 8:

Secure Tail Bar into the passenger side and driver side receivers. Press down on the Tail Bar until it snaps into place.

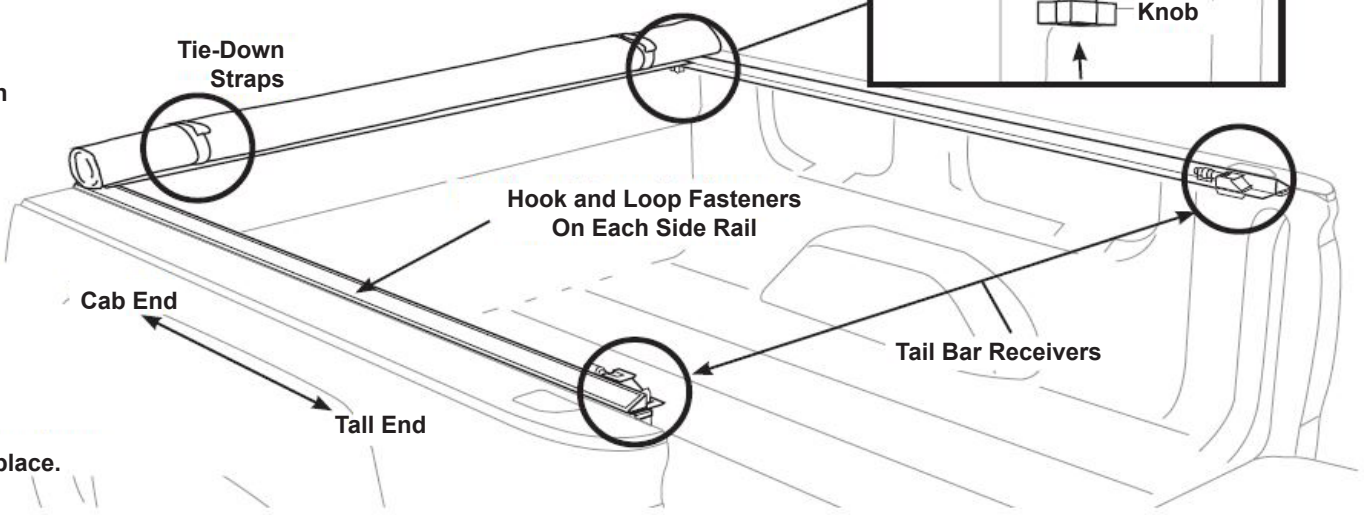

Step 9:

If the Tail Bar does not engage or cover is not taugt, adjust driver and passenger side cover tensioners to increase or decrease cover tension. Ensure both tensioners are positioned at the same marking. Tension adjustment is done with cover loose on the side rails. Repeat Step 8.

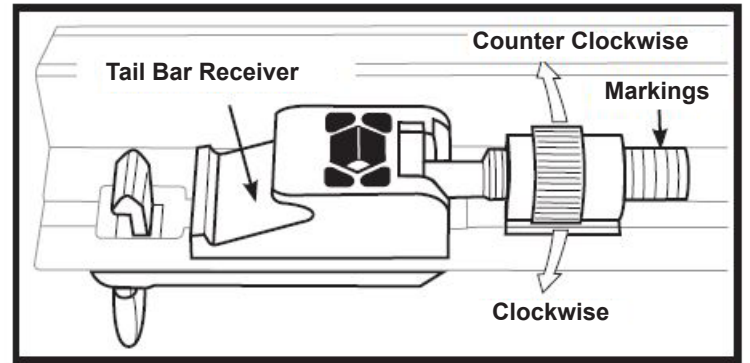



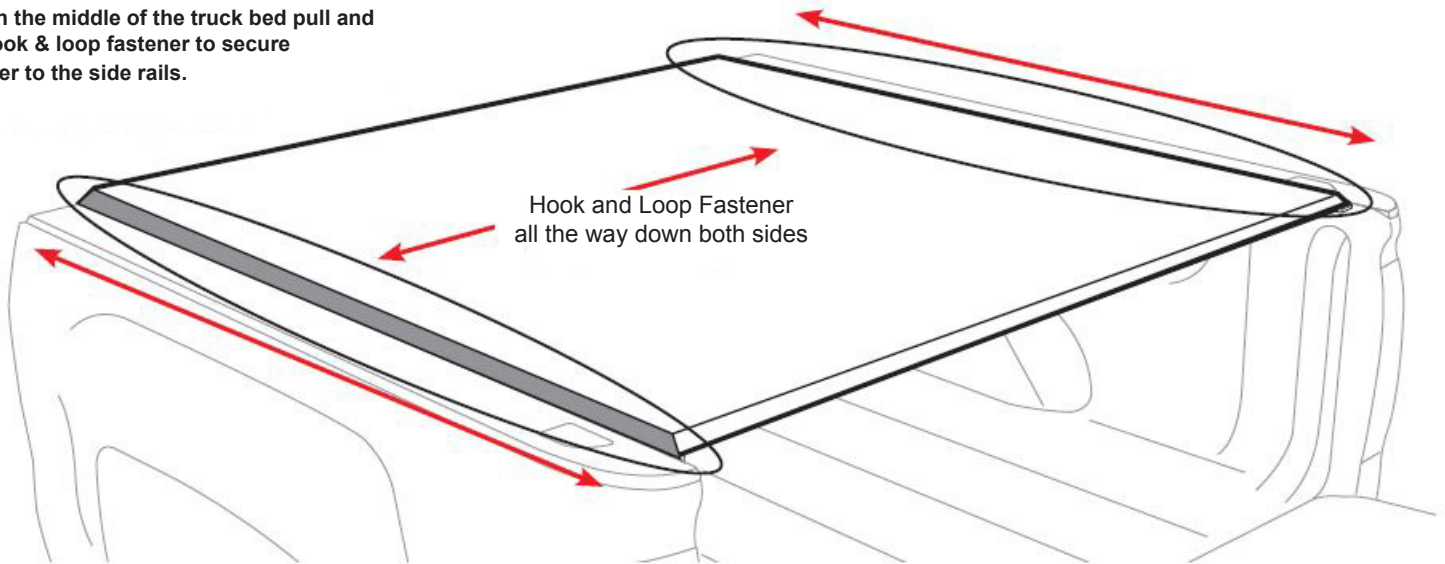

Step 10:

Beginning in the middle of the truck bed pull and place the hook & loop fastener to secure the soft cover to the side rails.



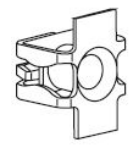
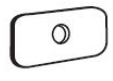

Cache-caisse souple à enroulement

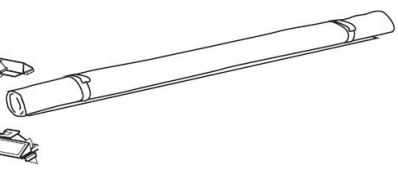
Pièces requises pour la pose :

<p>Guide de perçage</p>  <p>x2</p>	<p>Écrous borgnes</p>  <p>x4</p>	<p>Plaques d'appui</p>  <p>x8</p>	<p>Boulons</p>  <p>x12</p>	<p>Longeron côté passager x1</p>  <p>(B)</p>  <p>(A)</p> <p>Longeron côté conducteur x1</p>  <p>Cache-caisse à enroulement x1</p>
---	---	--	---	--

Outils requis :

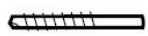
<p>Torx T30</p> 	<p>Perceuse</p> 	<p>Foret 7,0 mm (9/32 po)</p> 
---	---	---

Préparation :

- Déterminer les points de fixation de la caisse de camionnette (Étape 1)
- Percer le capuchon de longeron en plastique aux points de fixation (Étape 3 et étape 4)

Directives d'installation :

Lire l'ensemble des directives avant de procéder. Il est recommandé que deux personnes procèdent à la pose du cache-caisse.

Étape 1 :

Rechercher les points de fixation de la caisse de camionnettes des longerons du côté conducteur et côté passager. Les points de fixation sont des trous dans la tôle de la caisse de camionnettes derrière un capuchon de longeron en plastique.

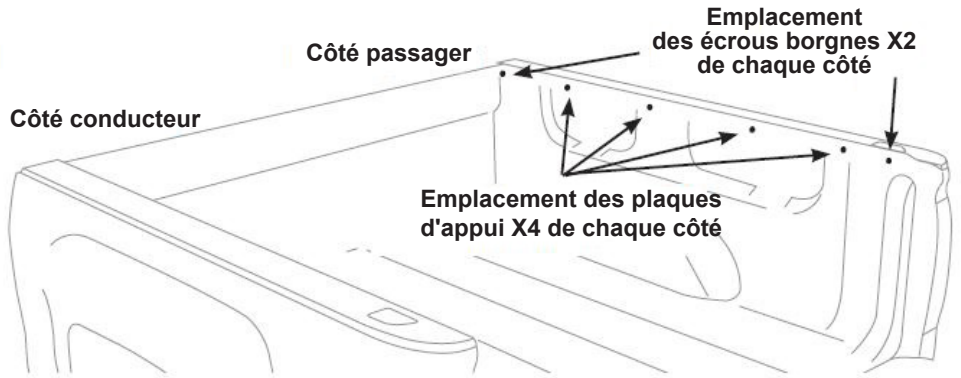

Étape 2 :

Poser un écrou borgne à chacune des quatre (4) positions de montant de coin. Les écrous borgnes s'insèrent dans la tôle de caisse de camionnette, comme indiqué ci-dessous. Pour accéder aux trous de montant de coin, tirer vers l'arrière les capuchons de longeron en plastique. Presser les écrous borgnes en place de façon à ce qu'ils affleurent la tôle.

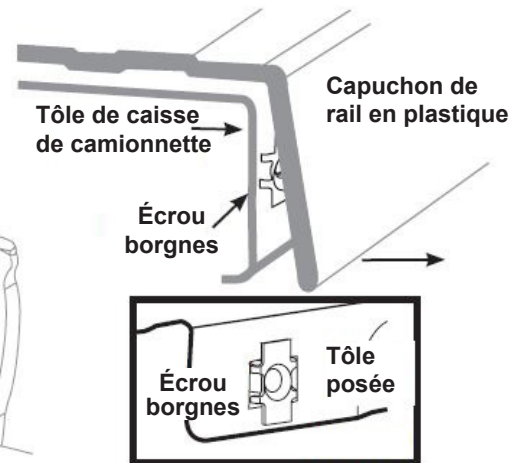
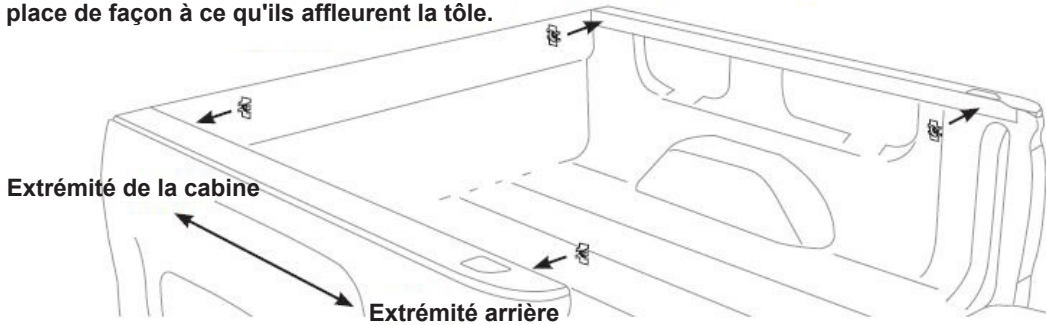

Étape 3 :

Une fois les écrous borgnes posés, soulever le capuchon de longeron en plastique et positionner l'entrée du filetage de l'écrou borgne avec le guide de perçage. Percer à travers le capuchon de longeron en plastique avec un foret de 7,0 mm (9/32 po). Répéter la procédure pour les quatre (4) coins.

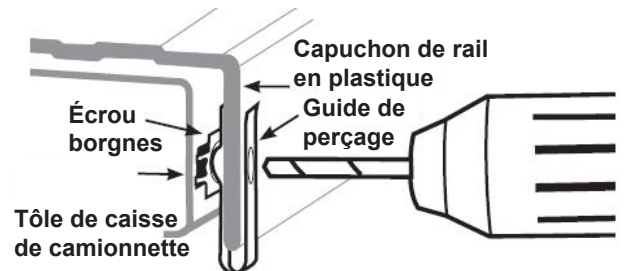

Directives d'installation :

Étape 4 :

Soulever le capuchon de longeron en plastique et déterminer les trous de fixation de plaque d'appui avec le guide de perçage. Percer à travers le capuchon de longeron en plastique avec un foret de 7,0 mm (9/32 po). Répéter la procédure pour les huit (8) emplacements de plaque d'appui.

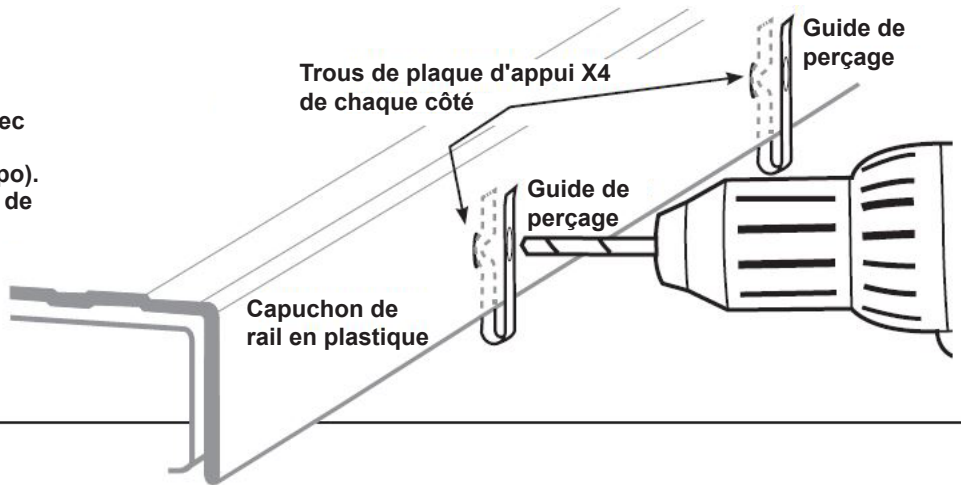

Pose de longeron :

Étape 5 :

Poser le longeron côté conducteur (A) dans l'ordre indiqué. Serrer à la main les boulons de fixation 1 et 2 dans les écrous borgnes. Serrer à la main les boulons 3, 4, 5 et 6 dans les plaques d'appui. Aligner le bord du joint d'étanchéité de longeron avec le dessus du capuchon de garniture en plastique, comme indiqué à la figure A. Utiliser un embout Torx T30 pour serrer complètement les boulons 3, 4, 5 et 6, suivis des boulons 1 et 2 vers 8.7 N-m. Répéter la procédure pour le longeron du côté passager (B).

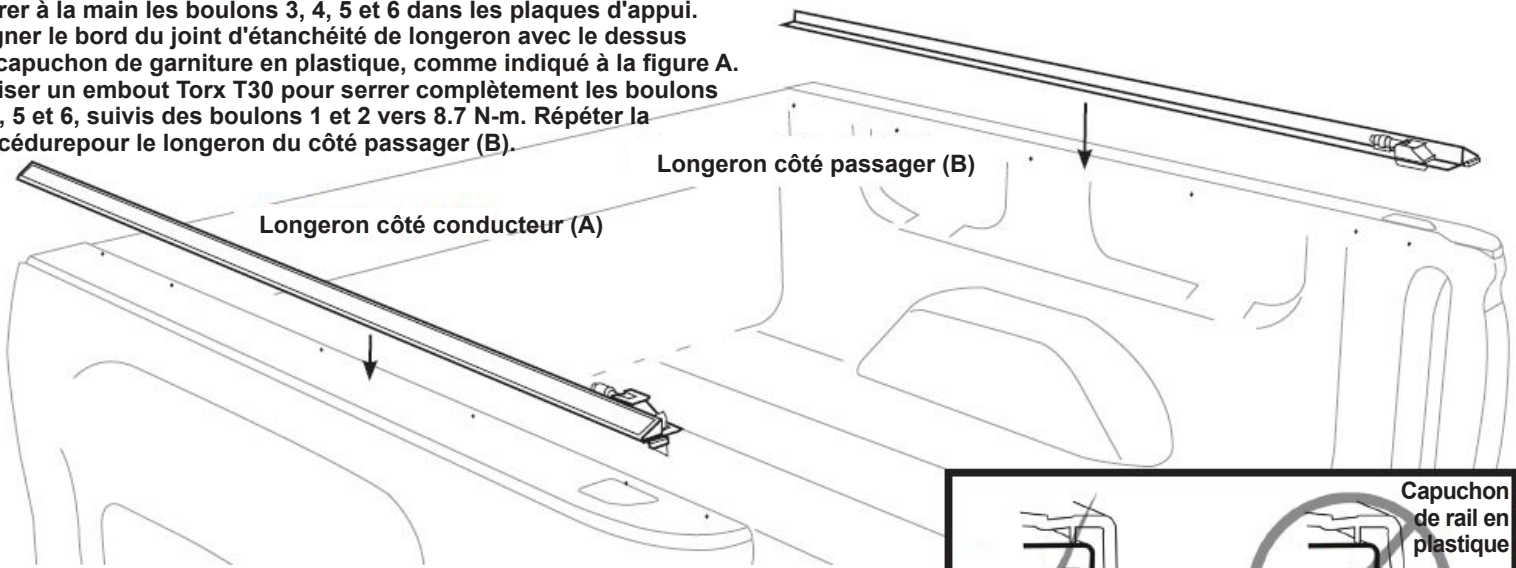

Les plaques d'appui se posent à l'endos de la tôle. **NE PAS** poser les plaques d'appui entre les capuchons de garniture en plastique et la tôle.

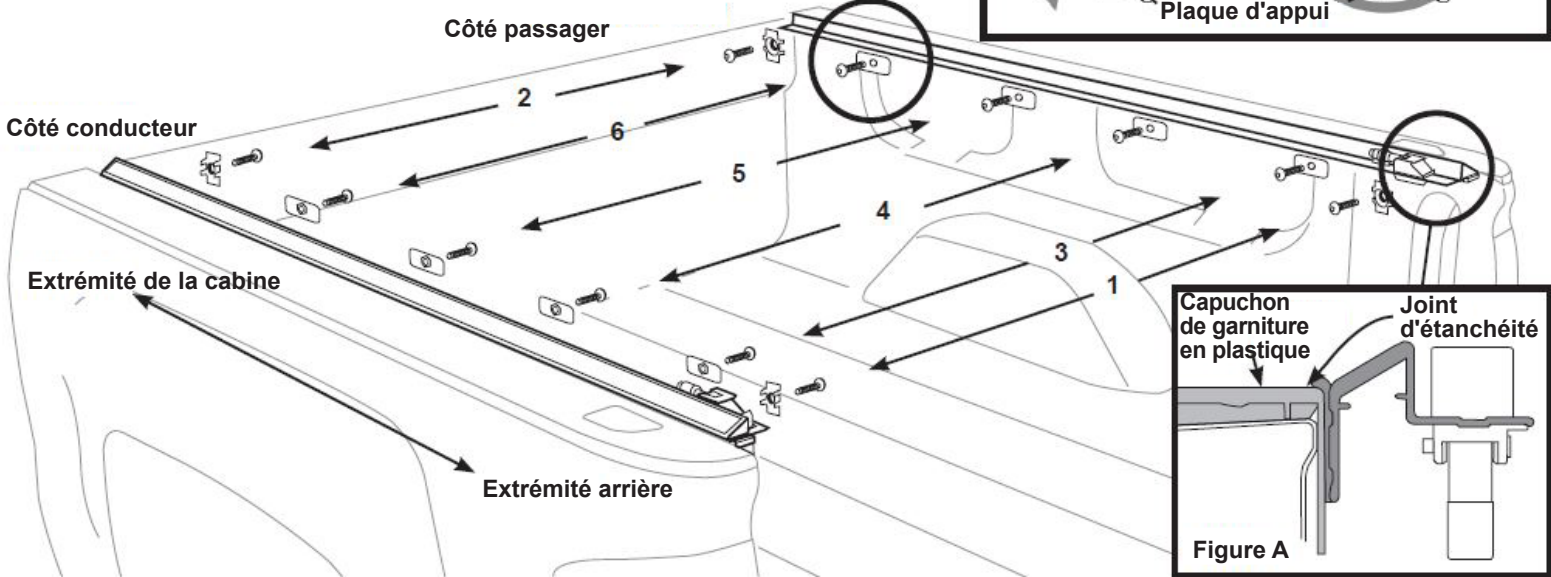
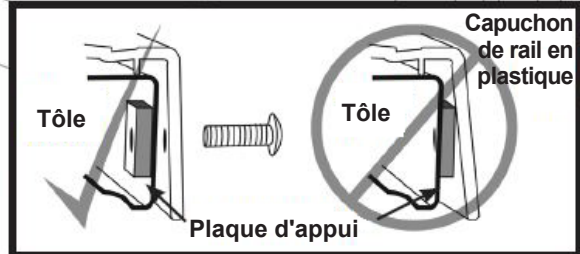

Pose du couvercle :

Étape 6 :

Retirer les molettes et les rondelles du boulon de serrage de la barre côté cabine. Centrer la barre côté cabine entre les longerons du côté conducteur et du côté passager. Insérer les boulons de serrage de barre côté cabine dans les trous des longerons côté conducteur et côté passager. Disposer le joint d'étanchéité de cabine sur le dessus de la paroi côté cabine de la caisse de camionnette. Remettre en place la rondelle et serrer les molettes du côté passager vers 8.7 N-m et du côté conducteur.

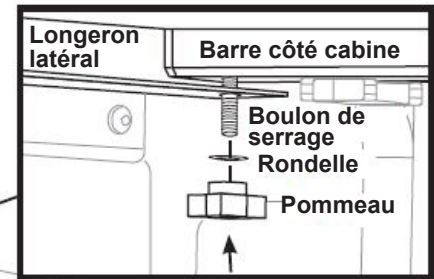

Étape 7 :

Dégager les sangles d'attache et dérouler le cache-caisse.

Étape 8 :

Fixer la barre d'extrémité dans les réceptacles du côté passager et du côté conducteur. Presser la barre d'extrémité jusqu'à ce qu'elle s'engage en place.

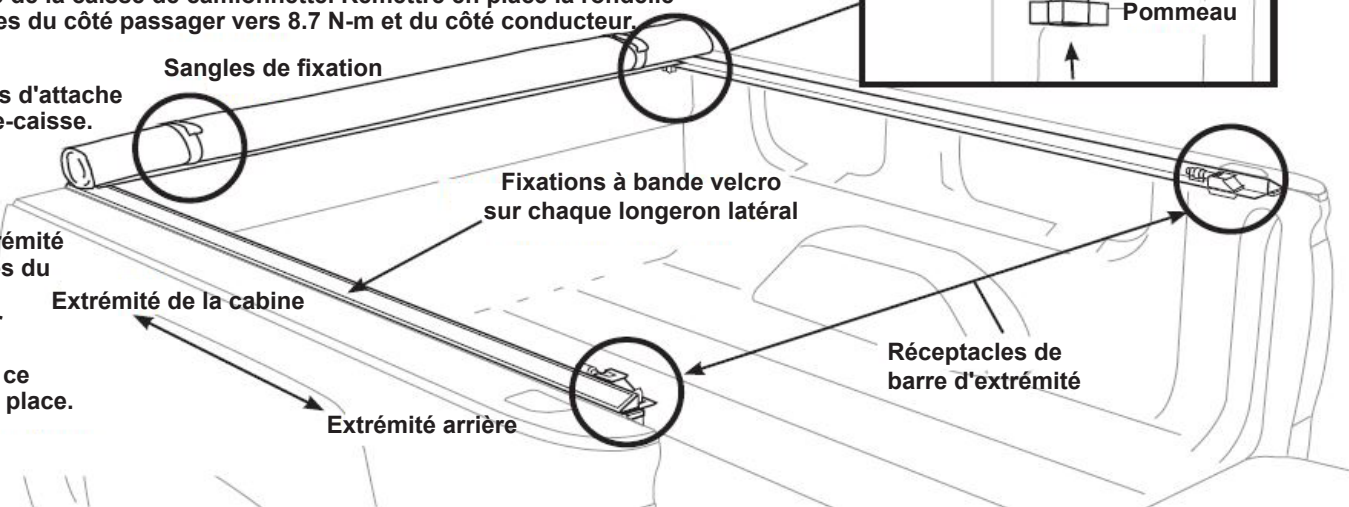

Étape 9 :

Si la barre d'extrémité ne s'engage pas ou si le cache-caisse n'est pas bien ajusté, régler les tendeurs du côté conducteur et du côté passager pour augmenter ou diminuer la tension du cache-caisse. S'assurer que les deux tendeurs sont positionnés au même repère. Le réglage de la tension se fait lorsque le cache-caisse n'est pas fixé sur les longerons latéraux. Répéter l'étape 8.

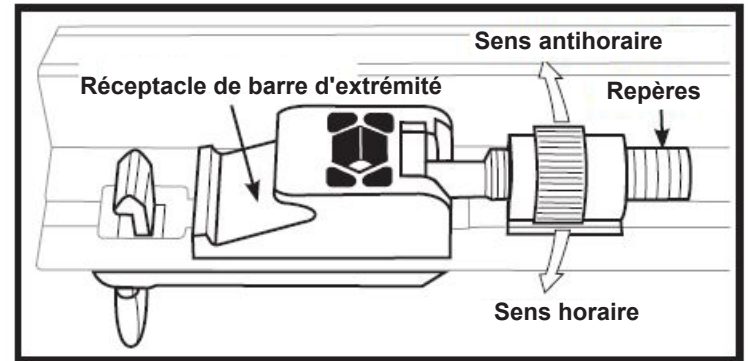



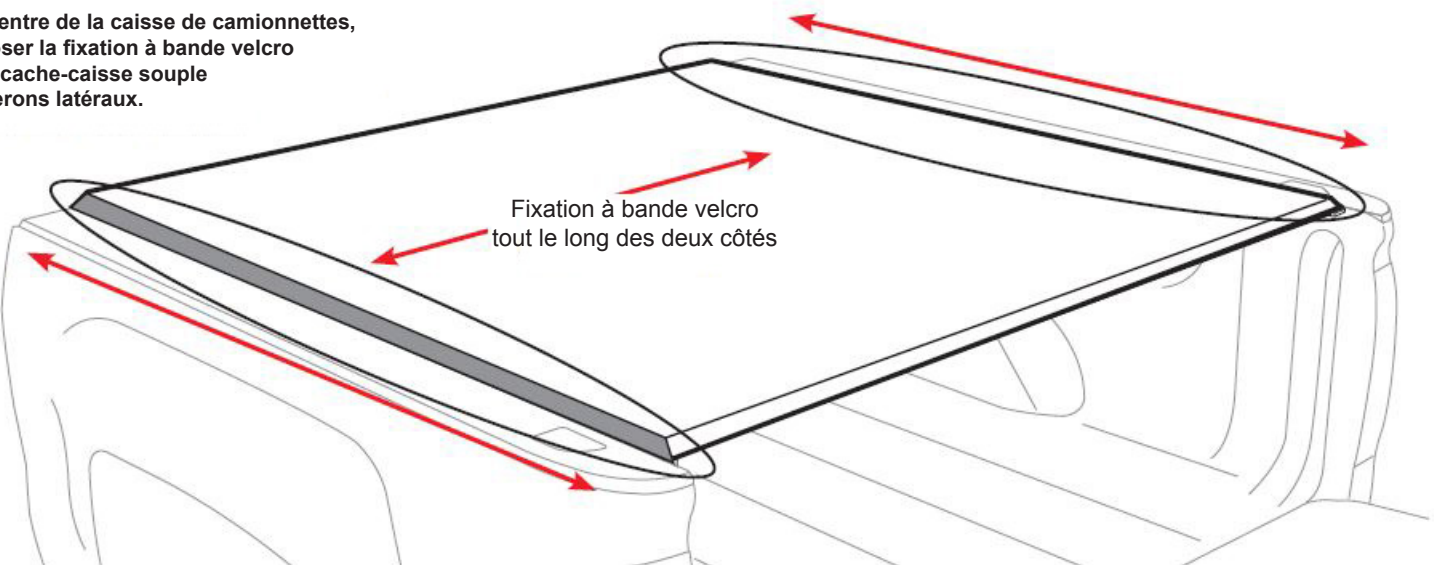

Étape 10 :

À partir du centre de la caisse de camionnettes, tirer et disposer la fixation à bande velcro pour fixer le cache-caisse souple sur les longerons latéraux.



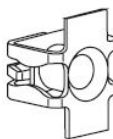

Cubierta suave enrollable para caja de camioneta

Las partes para la instalación incluyen:

Guía para taladrar  x2	Tuercas de caja  x4	Placas posteriores  x8	Tornillos  x12	Riel del lado del pasajero x1  (B)  (A)	Riel del lado del conductor x1 Cubierta para caja de camioneta x1
---	--	---	---	---	--

Herramientas requeridas:

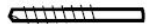
Torx T30 	Taladro 	Broca de 7.0 mm (9/32") 
---	--	--

Preparaciones:

- Identificar los puntos de fijación de la caja de la camioneta (Paso 1)
- Perforar la tapa de riel de plástico en los puntos de fijación (Paso 3 y Paso 4)

Instrucciones de Instalación:

Lea todas las instrucciones antes de continuar. Se recomienda que dos personas instalen la cubierta para caja de camioneta.

Paso 1:

Localice los puntos de fijación en la caja de la camioneta para los rieles del lado del conductor y del lado del pasajero. Los puntos de fijación son orificios en la lámina de la caja de la camioneta detrás de la tapa de riel de plástico.

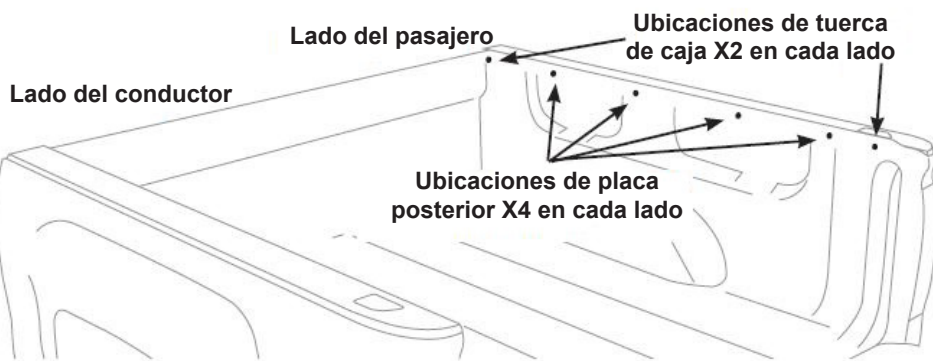

Paso 2:

Instale una tuerca de caja en cada una de las cuatro (4) posiciones del poste de esquina. Las tuercas de caja se insertan en la lámina de la caja de la camioneta como se muestra enseguida. Acceda a los orificios del poste de esquina jalando hacia atrás las tapas de riel de plástico. Oprima las tuercas de caja encajándolas en su lugar para que queden al ras de la lámina.

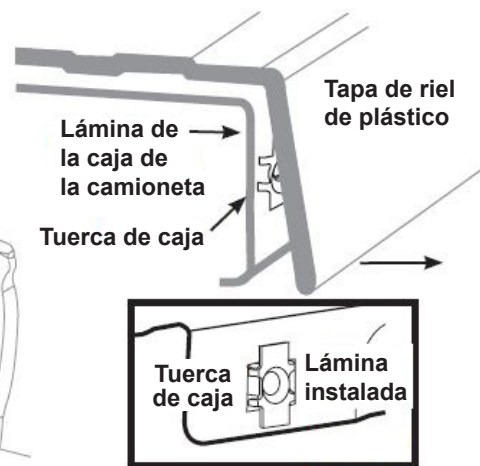

Paso 3:

Después de instalar las tuercas de caja, levante la tapa de riel de plástico y localice la entrada de la rosca de la tuerca de caja con la guía para taladrar. Perfore a través de la tapa de riel de plástico con una broca de 7.0 mm (9/32"). Repita para las cuatro (4) esquinas.

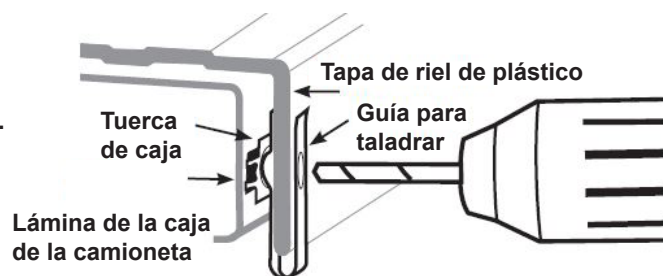

Instrucciones de Instalación:

Paso 4:

Levante la tapa de riel de plástico y localice los orificios de fijación de placa posterior con la guía para taladrar. Perfore a través de la tapa de riel de plástico con una broca de 7.0 mm (9/32"). Repita para las ocho (8) ubicaciones de placa posterior.

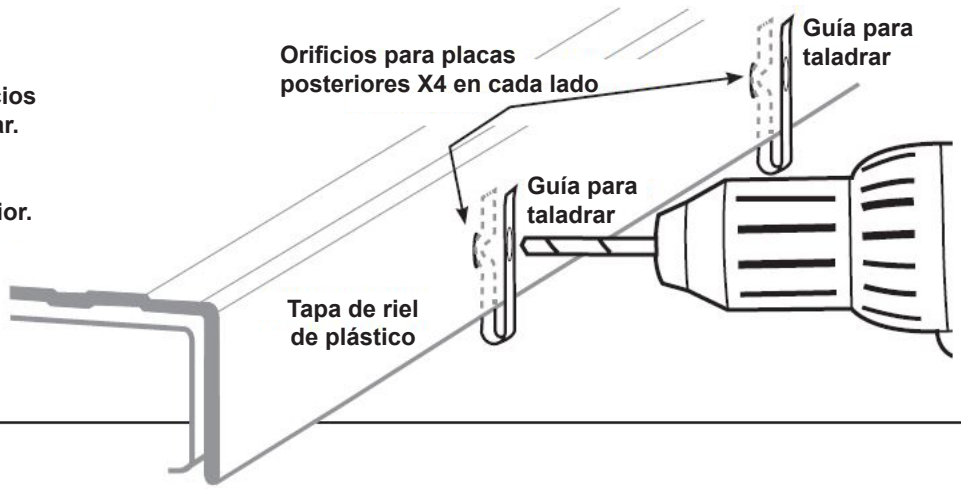

Instalación de riel lateral:

Paso 5:

Instale el riel del lado del conductor (A) en el orden que se muestra. Apriete a mano el perno de fijación 1 y 2 en las tuercas de caja. Apriete a mano 3, 4, 5 y 6 en las placas posteriores. Alinee el borde del sello del riel con la parte superior de la tapa decorativa de plástico como se muestra en la figura A. Use destornillador Torx T30 para apretar completamente los pernos 3, 4, 5 y 6 seguidos por los pernos 1 y 2 a 8.7 N-m. Repita para el riel del lado del pasajero (B).

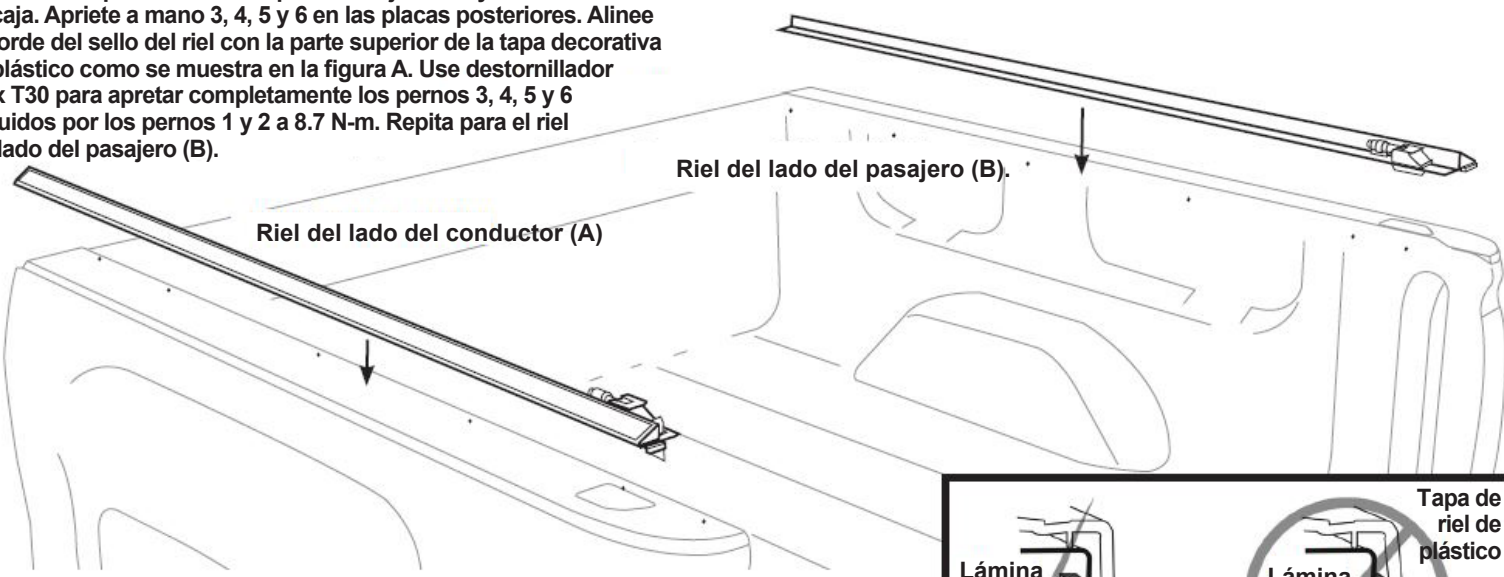

Las placas posteriores van instaladas en el lado de atrás de la lámina. NO instale las placas posteriores entre las tapas decorativas de plástico y la lámina.

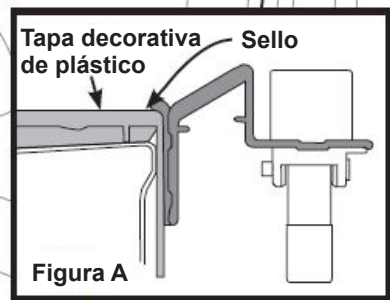
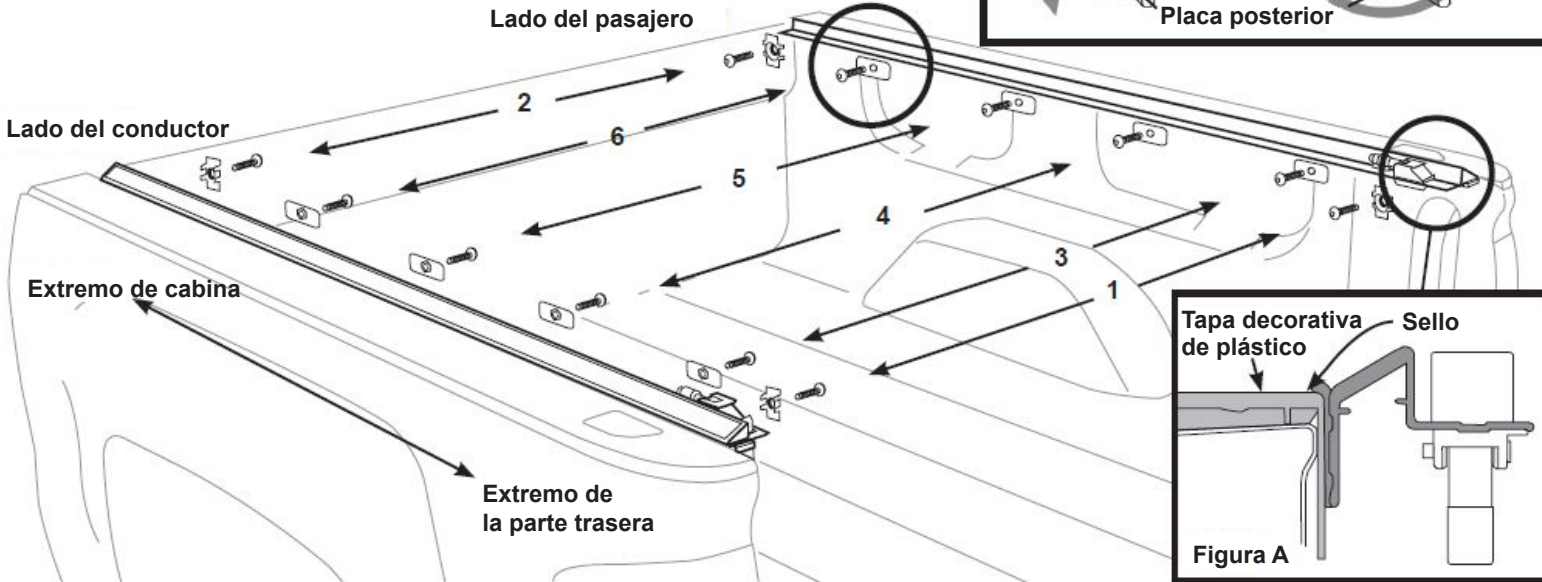
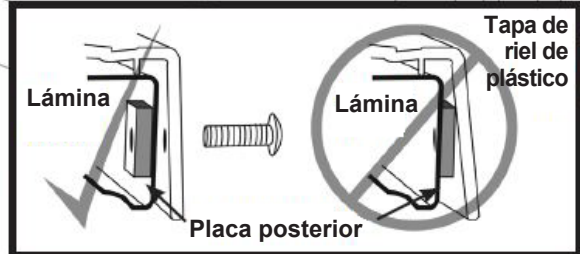

Instalación de cubierta:

Paso 6:
 Retire las perillas y las arandelas del perno de abrazadera de la barra de cabina
 Centre la barra de cabina entre los rieles del lado del conductor y del pasajero.
 Posicione los pernos de abrazadera de la barra de cabina a través de los orificios en los rieles del lado del conductor y del pasajero. Coloque el sello de cabina sobre el lado superior de la pared de cabina de la caja de la camioneta. Reemplace la arandela y apriete las perillas del lado del pasajero y del conductor a 8.7 N-m.

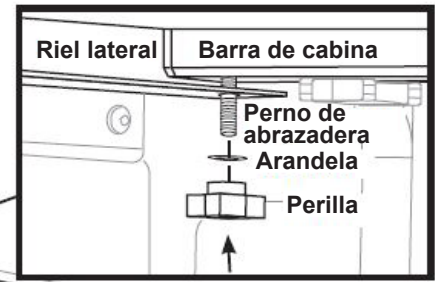

Paso 7:
 Desenganche las correas de amarre y desenrolle la cubierta.

Paso 8:
 Sujete la barra de la parte trasera en los receptores del lado del pasajero y del lado del conductor. Oprima la barra de la parte trasera hasta que encaje en su lugar.

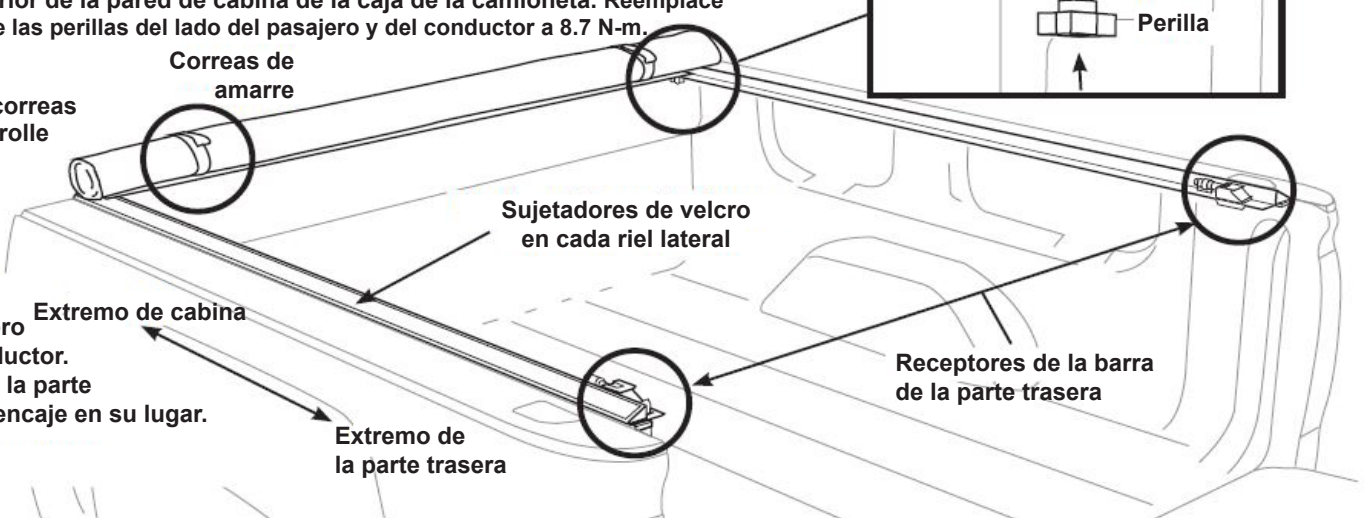

Paso 9:
 Si la barra de la parte trasera no engancha o la cubierta no está tensa, ajuste los tensores de cubierta del lado del conductor y del pasajero para aumentar o reducir la tensión de la cubierta. Asegúrese de que ambos tensores estén posicionados en la misma marca. El ajuste de tensión se hace con la cubierta floja sobre los rieles laterales. Repita el Paso 8.

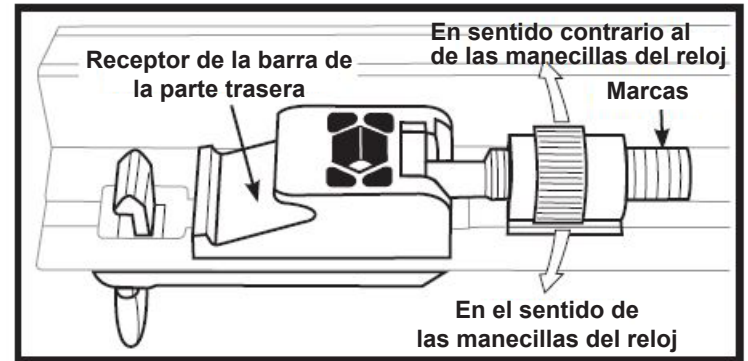

Paso 10:
 Comenzando en la parte media de la caja de la camioneta, jale y coloque el sujetador de velcro para sujetar la cubierta suave a los rieles laterales.

