

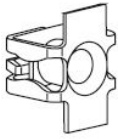







Soft Tri-Fold Tonneau

Installation Parts Includes:

Drill Guide  x2	Box Nuts  x4	Backing Plates  x8	Bolts  x12	Passenger Side Rail (2 notches) x1   Driver Side Rail (3 notches) x1 Soft Tri-Fold Tonneau Cover x1
--	---	---	---	--

Tools Required:

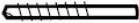
T30 Torx 	7/16" Deep Socket 	Drill 	7.0mm (9/32") Drill Bit 
---	--	--	--

Preparations:

- Identify truck bed attachment points (Step 1)
- Drill plastic rail cap at attachment points (Step 3 and Step 4)

Installation Instructions:

Read all instructions before proceeding. It is recommended that two people install the tonneau cover.

Step 1:

Locate truck bed attachment points for driver side and passenger side rails. Attachment points are holes in truck bed sheet metal behind the plastic rail cap.

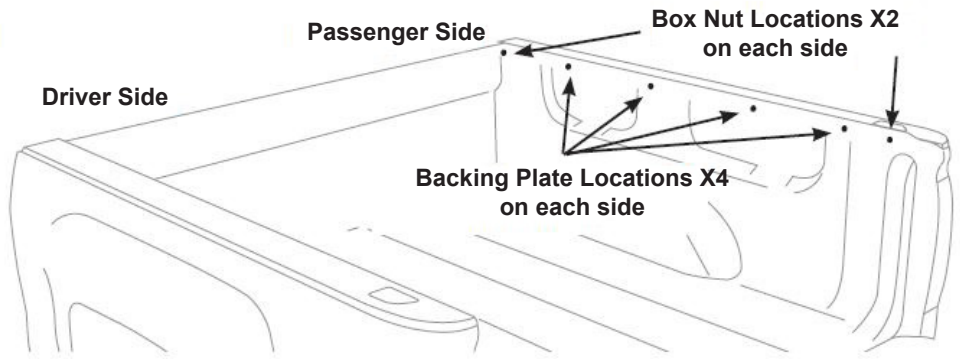

Step 2:

Install a Box Nut in each of the four (4) corner pillar positions. Box nuts are inserted in truck bed sheet metal as shown below. Access corner pillar holes by pulling back the plastic rail caps. Press box nuts in place so they are flush with the sheet metal.

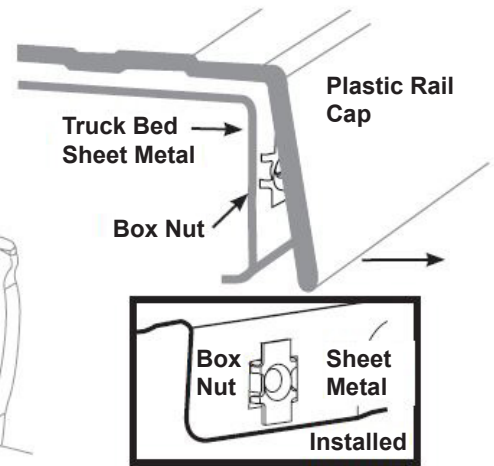
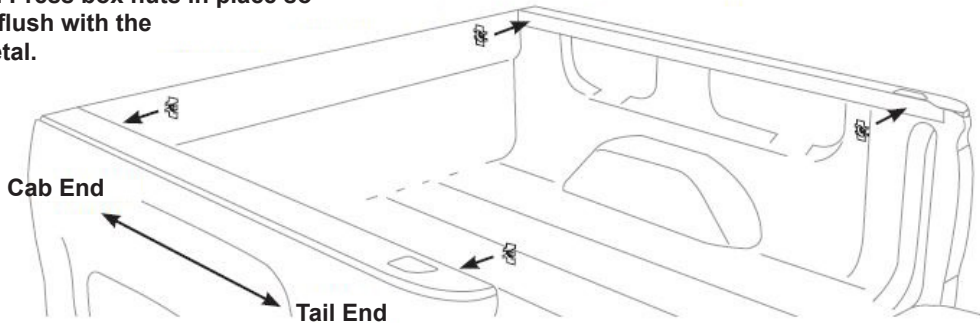

Step 3:

After installing the box nuts lift the plastic rail cap and locate the Box Nut thread inlet with the drill guide. Drill through the plastic rail cap with 7.0mm (9/32") drill bit. Repeat for all four (4) corners.

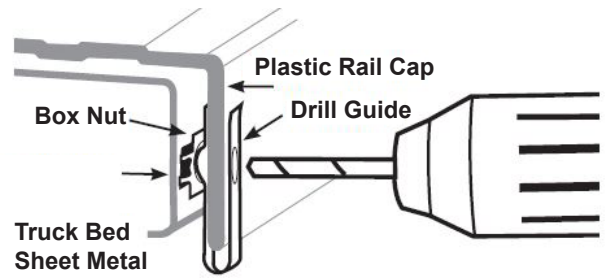

Installation Instructions:

Step 4:

Lift the plastic rail cap and locate backing plate attachment holes with the Drill Guide.
 Drill through the plastic rail cap with 7.0mm (9/32") drill bit.
 Repeat for all eight (8) backing plate locations.

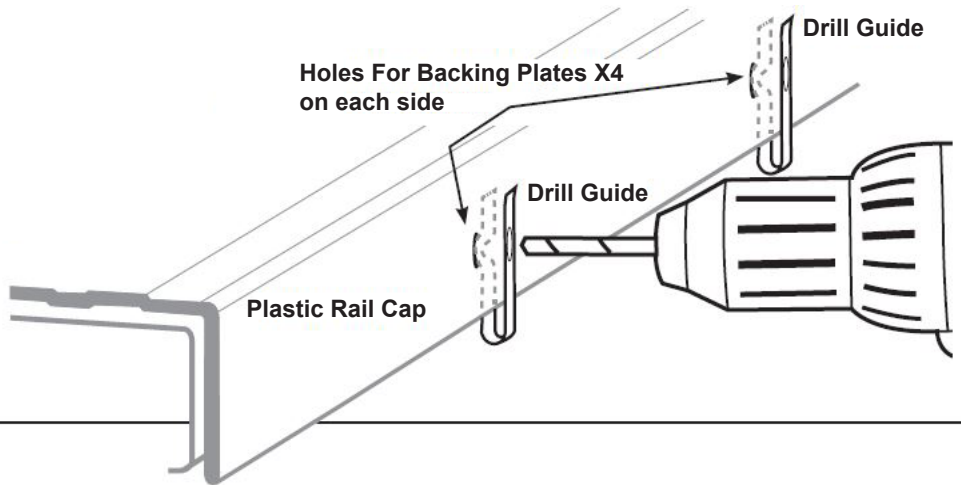

Side Rail Installation:

Step 5: Driver side rail (A) has three (3) notches. Passenger side rail (B) has two (2) notches.

Install driver side rail (A) in the order shown. Hand-tighten attachment bolt 1 and 2 in box nuts. Hand-tighten 3, 4, 5 and 6 into backing plates. Align the edge of the rail seal with the top of the plastic trim cap as shown in figure A. Use T30 Torx to fully tighten bolts 3, 4, 5 and 6 followed by bolts 1 and 2 to 8.7 N-m. Repeat for passenger side rail (B).

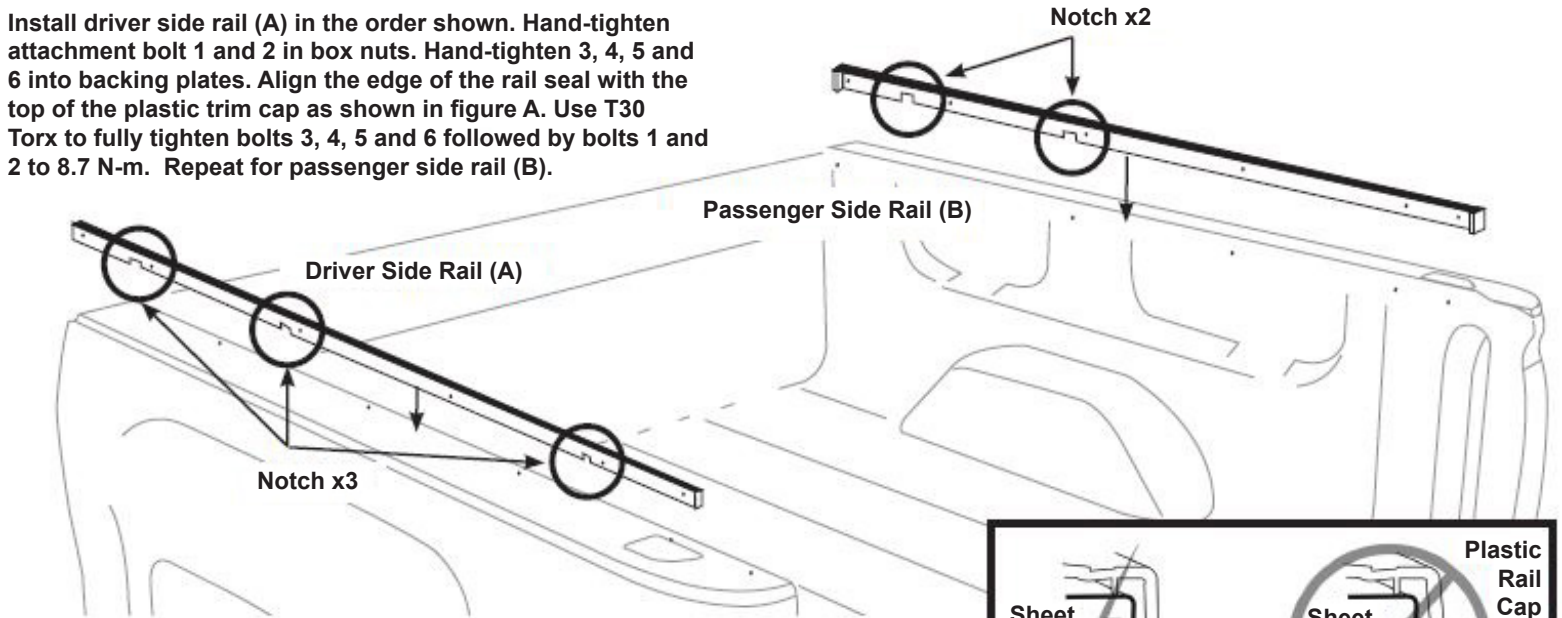

Backing plates are installed on the back side of the sheet metal.
DO NOT install backing plates between plastic trim caps and sheet metal.

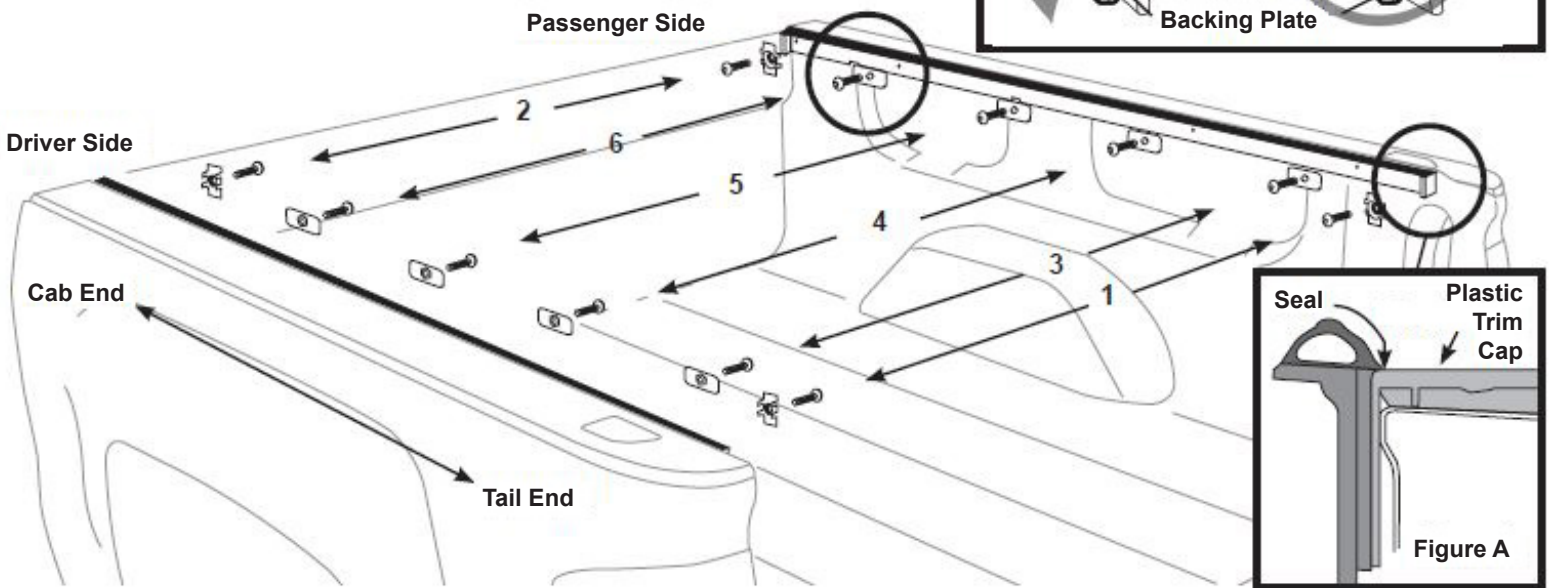
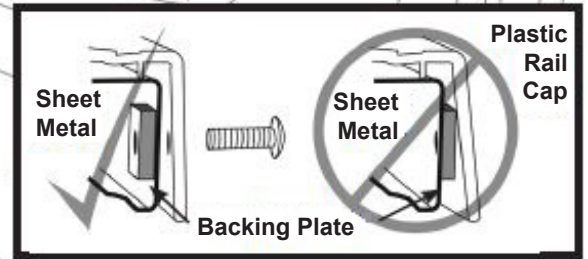

Cover Installation:

Step 6:

Locate the notch in the driver and passenger side rails closest to the cab wall of the truck bed. Align the stationary clamps to the notch. Position the cover evenly side to side and rest the cab seal smoothly along the cab wall of the bed. Position the stationary clamps so that the hook wraps around the sheet metal. Tighten the nut. Be sure to tighten each side evenly. Tighten until clamp hook contacts sheet metal then tighten an additional two (2) turns to 8.7 N-m. **DO NOT** secure stationary clamp to plastic trim cap or bedliner. **DO NOT** over tighten.

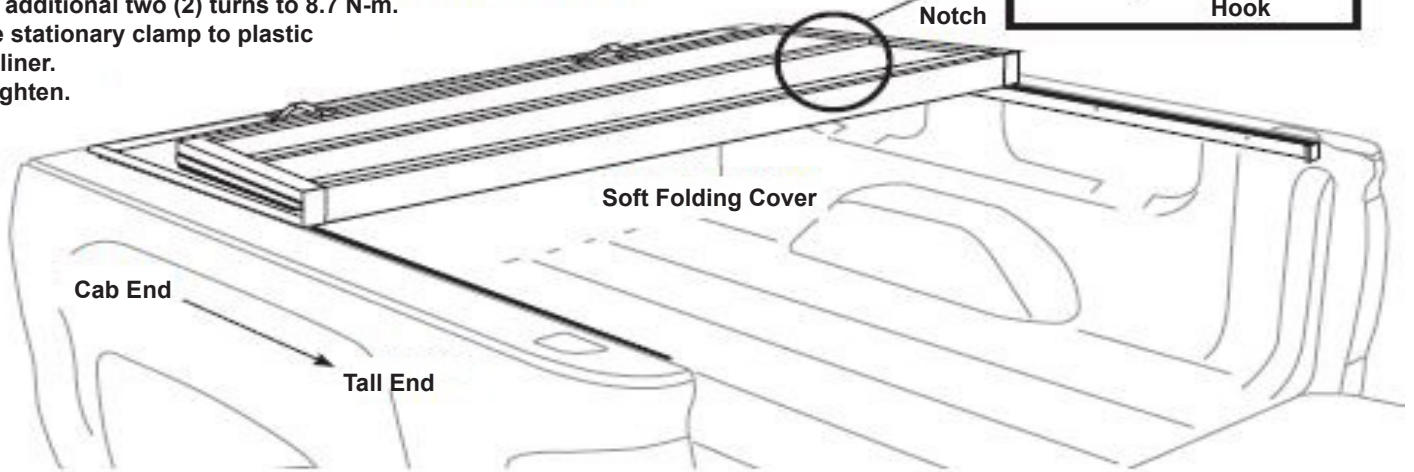
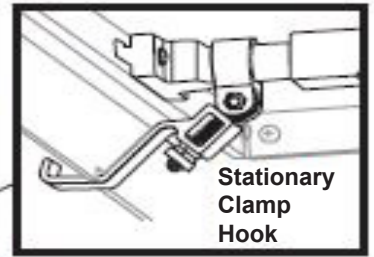

Step 7:

Unclip the tie down straps and unfold the tonneau.

Cover Installation

Step 8:

With both hands, press down on the rear bar until the rear slam latches engage driver side and passenger side rails.

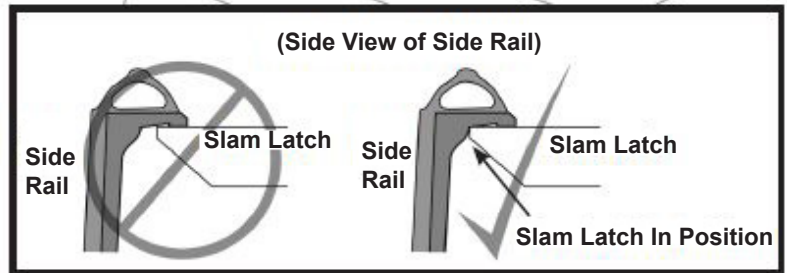
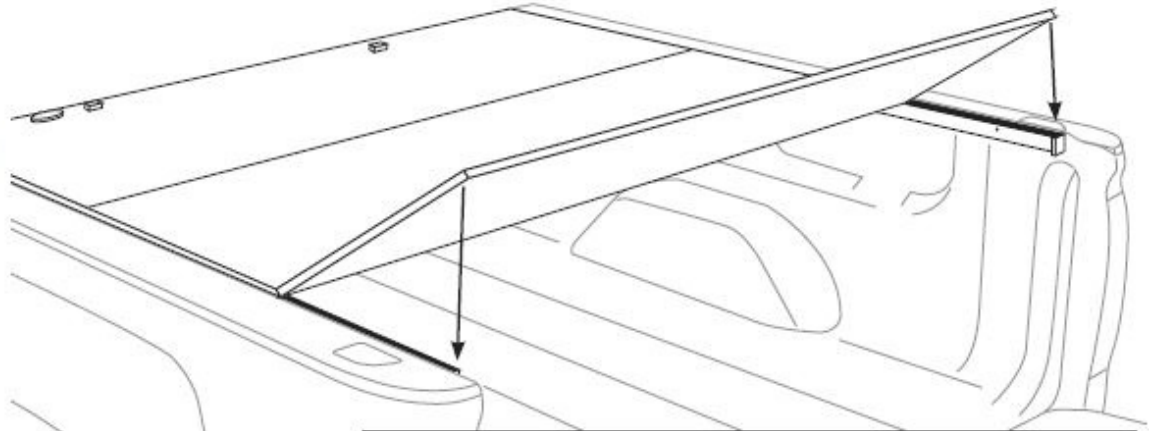

Cover Installation





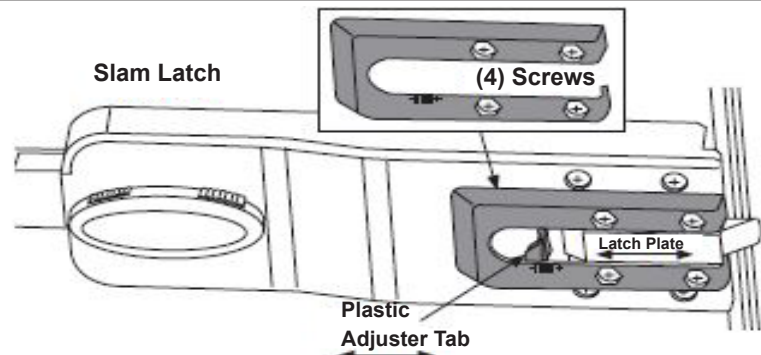

Step 9 (optional):

If the slam latches do not engage or there is excessive slack in the latches, adjust latches in or out and up or down. To adjust, loosen the four (4) screws. To move the latches in or out, move the metal latch plate. To move the latches up or down, move the plastic adjuster tab. Tighten the four (4) screws. Repeat Step 8.

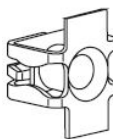





Cache-caisse souple à trois panneaux

Pièces requises pour la pose :

<p>Guide de perçage</p>  <p>x2</p>	<p>Écrous borgnes</p>  <p>x4</p>	<p>Plaques d'appui</p>  <p>x8</p>	<p>Boulons</p>  <p>x12</p>	<p>Longeron côté passager (2 encoches) x1</p> 	<p>Longeron côté conducteur (3 encoches) x1</p> 	<p>Cache-caisse souple à trois panneaux x1</p> 
---	---	--	---	--	--	--

Outils requis :

Préparation :

<p>Torx T30</p> 	<p>Douille profonde de 7/16 po</p> 	<p>Perceuse</p> 	<p>Foret 7,0 mm (9/32 po)</p> 	<ul style="list-style-type: none"> Déterminer les points de fixation de la caisse de camionnette (Étape 1) Percer le capuchon de longeron en plastique aux points de fixation (Étape 3 et étape 4)
---	--	---	---	--

Directives d'installation :

Lire l'ensemble des directives avant de procéder. Il est recommandé que deux personnes procèdent à la pose du cache-caisse.

Étape 1 :

Rechercher les points de fixation de la caisse de camionnettes des longerons du côté conducteur et côté passager. Les points de fixation sont des trous dans la tôle de la caisse de camionnettes derrière un capuchon de longeron en plastique.

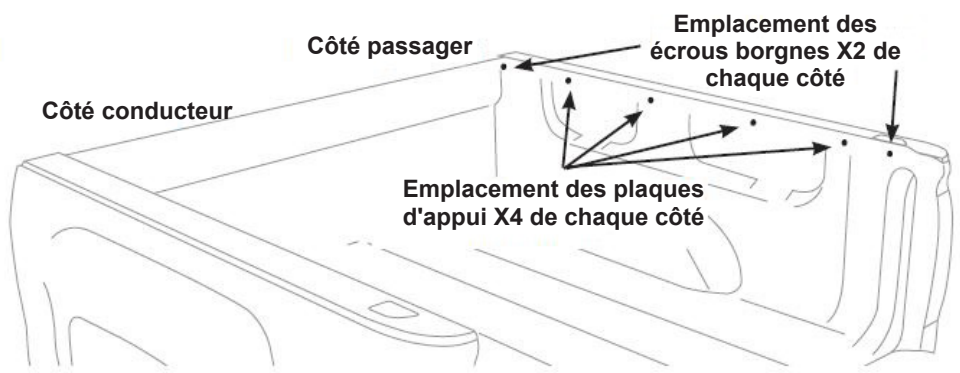

Étape 2 :

Poser un écrou borgne à chacune des quatre (4) positions de montant de coin. Les écrous borgnes s'insèrent dans la tôle de caisse de camionnette, comme indiqué ci-dessous. Pour accéder aux trous de montant de coin, tirer vers l'arrière les capuchons de longeron en plastique. Presser les écrous borgnes en place de façon à ce qu'ils affleurent la tôle.

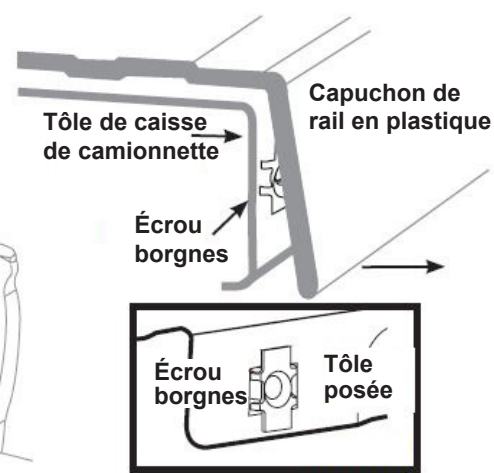
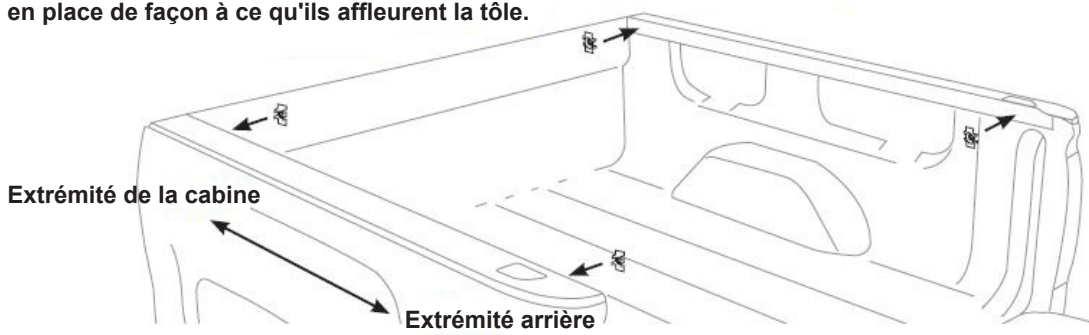

Étape 3 :

Une fois les écrous borgnes posés, soulever le capuchon de longeron en plastique et positionner l'entrée du filetage de l'écrou borgne avec le guide de perçage. Percer à travers le capuchon de longeron en plastique avec un foret de 7,0 mm (9/32 po). Répéter la procédure pour les quatre (4) coins.

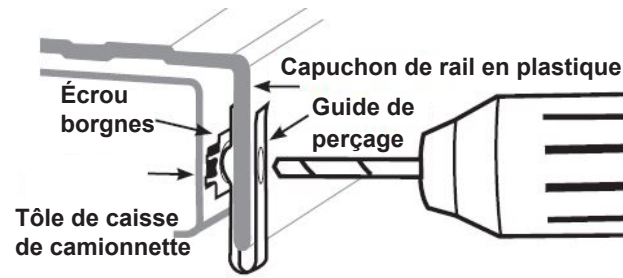

Directives d'installation :

Étape 4 :

Soulever le capuchon de longeron en plastique et déterminer les trous de fixation de plaque d'appui avec le guide de perçage. Percer à travers le capuchon de longeron en plastique avec un foret de 7,0 mm (9/32 po). Répéter la procédure pour les huit (8) emplacements de plaque d'appui.

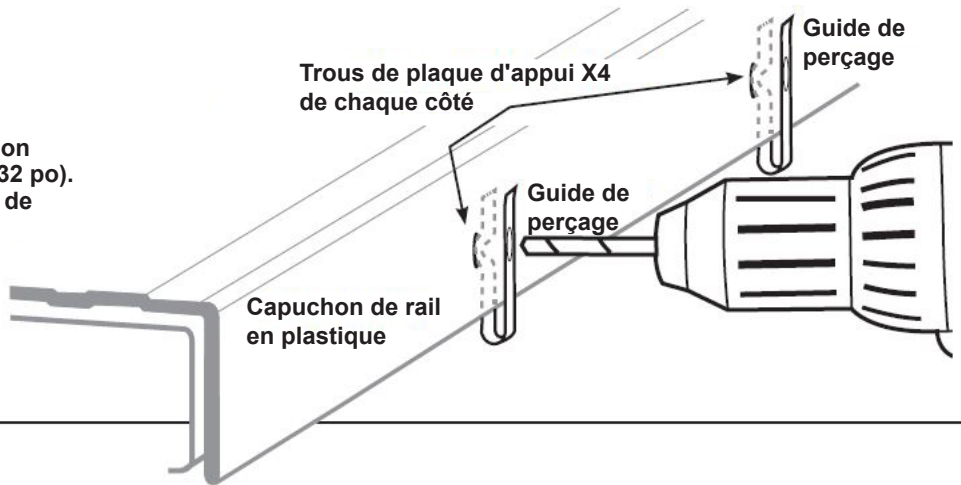

Pose de longeron :

Étape 5 : Le longeron côté conducteur (A) est doté de trois (3) encoches. Le longeron côté passager (B) est doté de deux (2) encoches

Poser le longeron côté conducteur (A) dans l'ordre indiqué. Serrer à la main les boulons de fixation 1 et 2 dans les écrous borgnes. Serrer à la main les boulons 3, 4, 5 et 6 dans les plaques d'appui. Aligner le bord du joint d'étanchéité de longeron avec le dessus du capuchon de garniture en plastique, comme indiqué à la figure A. Utiliser un embout Torx T30 pour serrer complètement les boulons 3, 4, 5 et 6, suivis des boulons 1 et 2 vers 8.7 N-m. Répéter la procédure pour le longeron du côté passager (B).

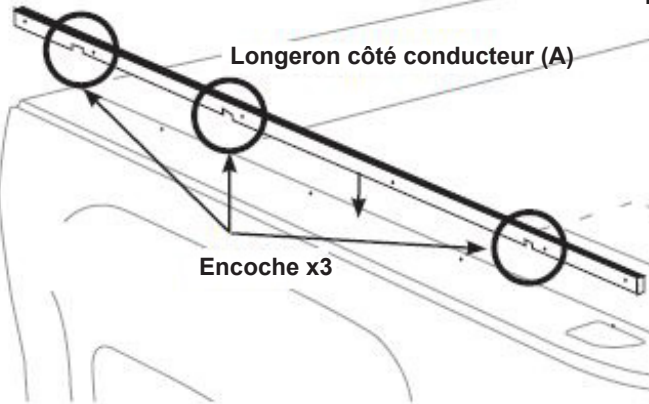
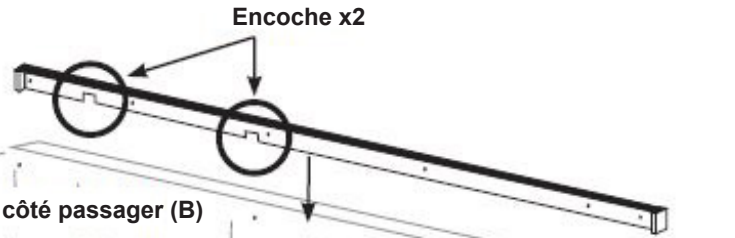

Les plaques d'appui se posent à l'endos de la tôle. **NE PAS** poser les plaques d'appui entre les capuchons de garniture en plastique et la tôle.

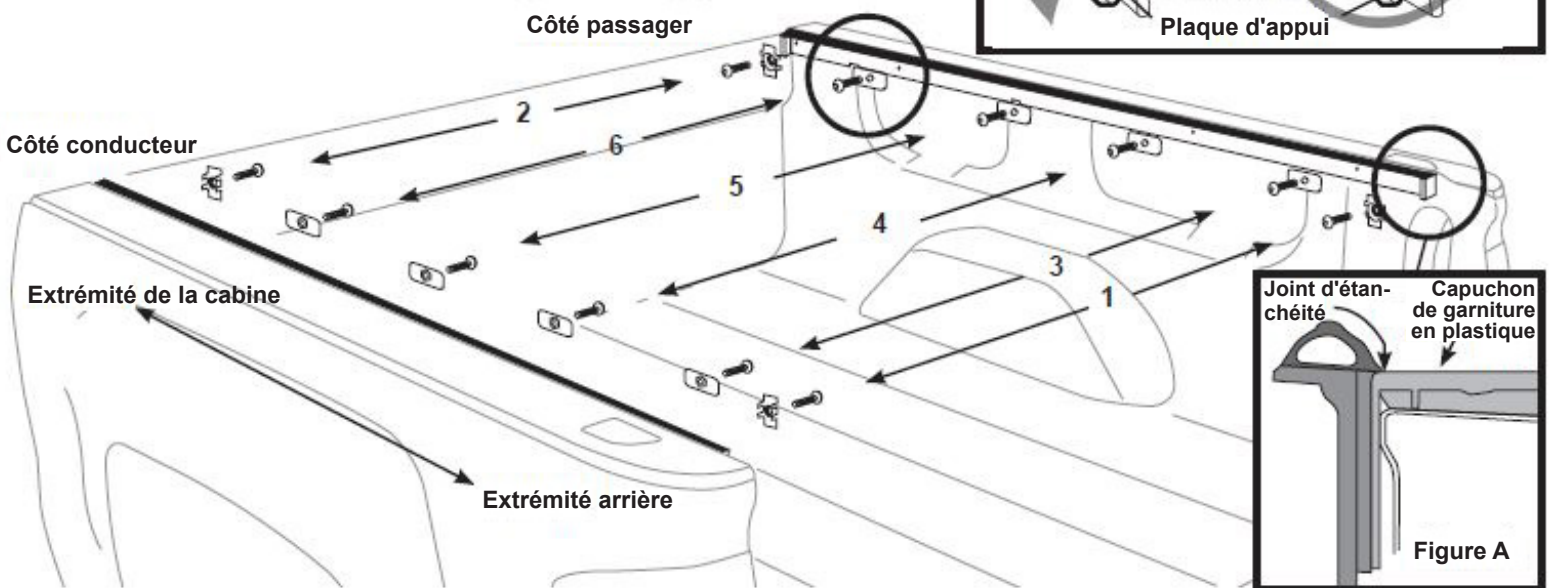

Pose du couvercle :

Étape 6 :

Rechercher l'encoche sur les longerons côté conducteur et côté passager le plus près de la paroi côté cabine de la caisse de camionnette. Aligner le dispositif de serrage fixe avec l'encoche. Disposer le cache-caisse uniformément d'un côté à l'autre et déposer soigneusement le joint d'étanchéité de cabine le long de la paroi côté cabine de la caisse. Disposer les dispositifs de serrage fixes de façon à ce que le crochet entoure la tôle. Serrer l'écrou. S'assurer de serrer chaque côté uniformément. Serrer jusqu'à ce que le crochet du dispositif de serrage touche à la tôle, puis serrer deux (2) tours supplémentaires vers 8.7 N-m. **NE PAS** fixer le dispositif de serrage fixe sur le capuchon de garniture en plastique ou sur la doublure de caisse. **NE PAS** trop serrer.

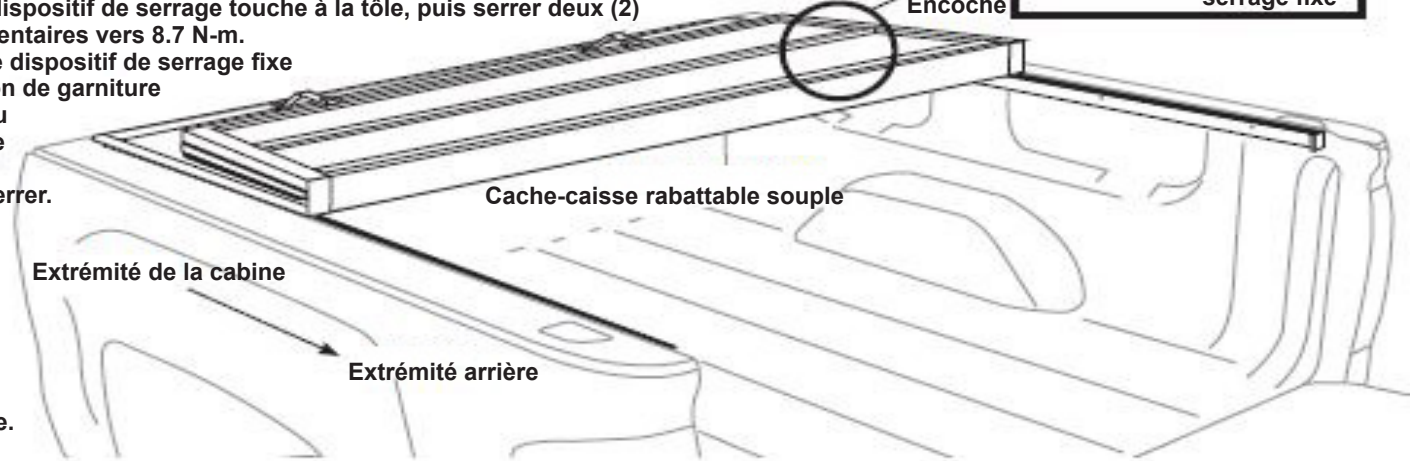
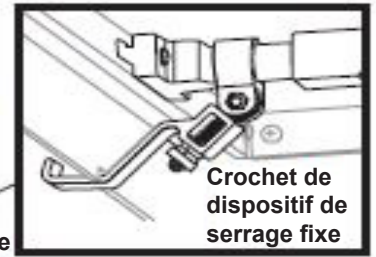

Étape 7 :

Dégager les sangles d'attache et enrouler le cache-caisse.

Pose du couvercle

Étape 8 :

Utiliser les deux main pour presser la barre arrière jusqu'à ce que les loquets à fermeture arrière s'engagent dans les longerons du côté conducteur et du côté passager.

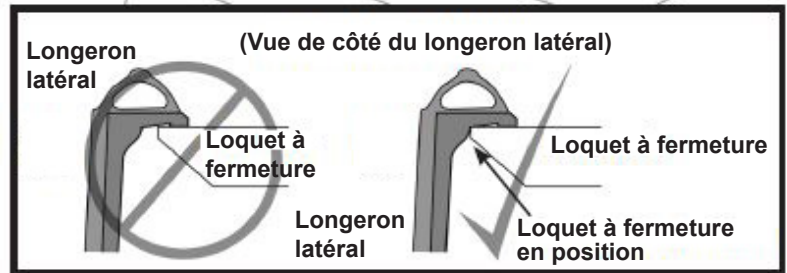
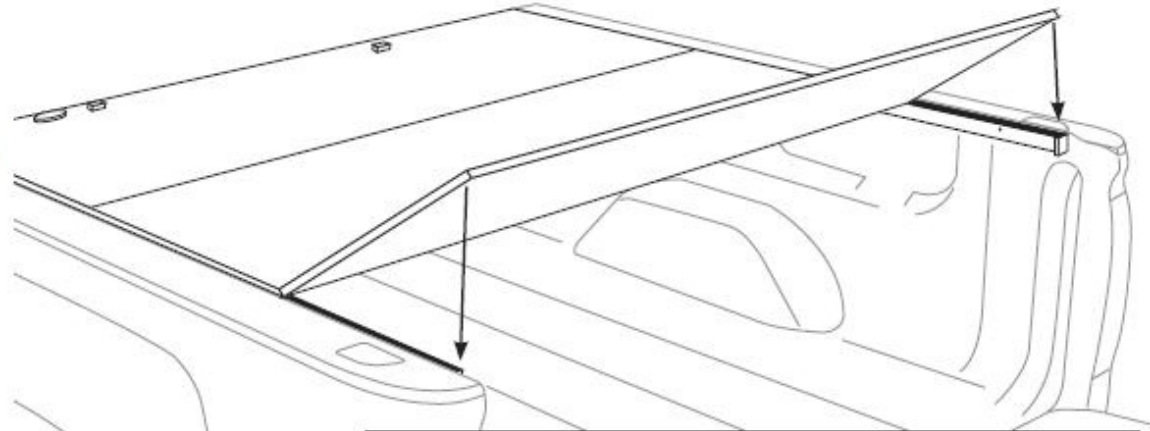

Pose du couvercle





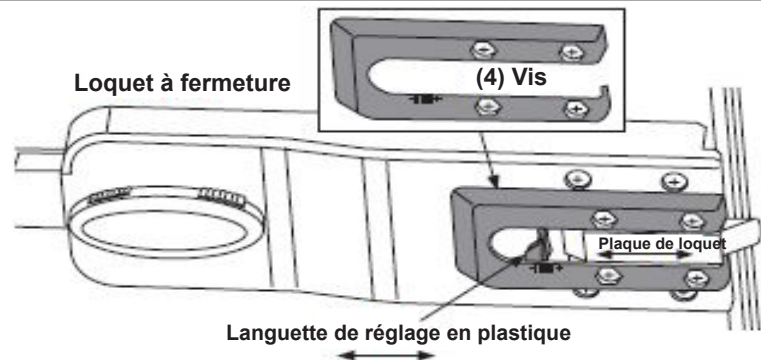

Étape 9 (facultative) :

Si les loquets à fermeture ne s'engagent pas ou s'ils présentent un jeu excessif, régler les loquets vers l'extérieur ou l'intérieur, puis vers le haut ou vers le bas. Pour effectuer le réglage, desserrer les quatre (4) vis. Pour déplacer les loquets vers l'intérieur ou l'extérieur, déplacer la plaque de loquet en métal. Pour déplacer les loquets vers le haut ou vers le bas, déplacer la languette de réglage en plastique. Serrer les quatre vis (4). Répéter l'étape 8.

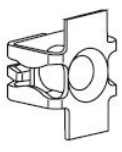





Cubierta suave plegable para caja de camioneta

Las partes para la instalación incluyen:

<p>Guía para taladrar</p>  <p>x2</p>	<p>Tuercas de caja</p>  <p>x4</p>	<p>Placas posteriores</p>  <p>x8</p>	<p>Tornillos</p>  <p>x12</p>	<p>Riel del lado del pasajero (2 muescas) x1</p>  <p>Riel del lado del conductor (3 muescas) x1</p>  <p>Cubierta suave plegable para caja de camioneta x1</p> 
---	--	---	---	---

Herramientas requeridas:

Preparaciones:

<p>Torx T30</p> 	<p>Casquillo de 7/16" de profundidad</p> 	<p>Taladro</p> 	<p>Broca de 7.0 mm (9/32")</p> 	<ul style="list-style-type: none"> Identificar los puntos de fijación de la caja de la camioneta (Paso 1) Perforar la tapa de riel de plástico en los puntos de fijación (Paso 3 y Paso 4)
---	--	--	---	--

Instrucciones de Instalación:

Lea todas las instrucciones antes de continuar. Se recomienda que dos personas instalen la cubierta para caja de camioneta.

Paso 1:

Localice los puntos de fijación en la caja de la camioneta para los rieles del lado del conductor y del lado del pasajero. Los puntos de fijación son orificios en la lámina de la caja de la camioneta detrás de la tapa de riel de plástico.

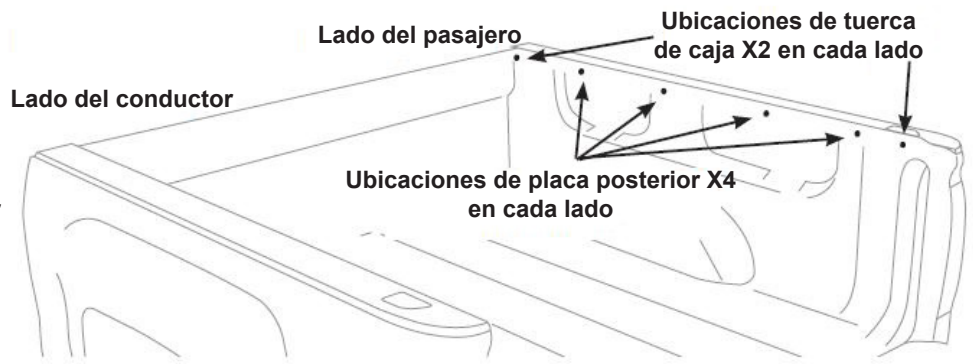

Paso 2:

Instale una tuerca de caja en cada una de las cuatro (4) posiciones del poste de esquina. Las tuercas de caja se insertan en la lámina de la caja de la camioneta como se muestra enseguida. Acceda a los orificios del poste de esquina jalando hacia atrás las tapas de riel de plástico. Oprima las tuercas de caja encajándolas en su lugar para que queden al ras de la lámina.

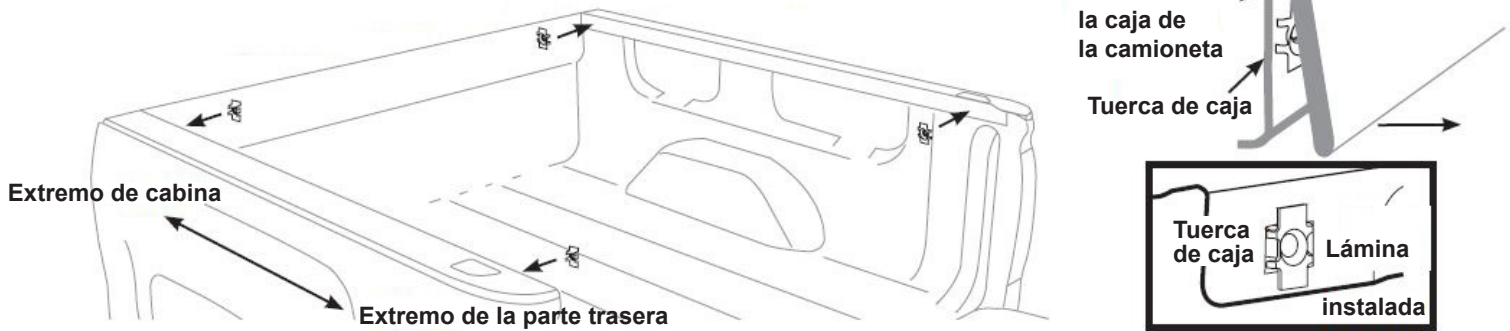

Paso 3:

Después de instalar las tuercas de caja, levante la tapa de riel de plástico y localice la entrada de la rosca de la tuerca de caja con la guía para taladrar. Perfore a través de la tapa de riel de plástico con una broca de 7.0 mm (9/32"). Repita para las cuatro (4) esquinas.

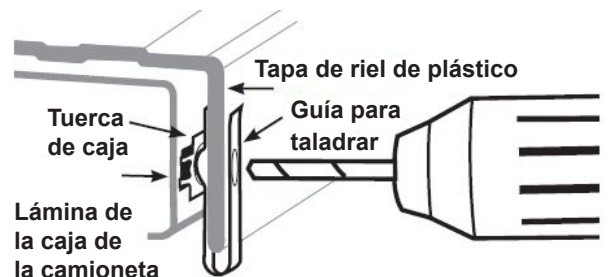

Instrucciones de Instalación:

Paso 4:

Levante la tapa de riel de plástico y localice los orificios de fijación de placa posterior con la guía para taladrar. Perfore a través de la tapa de riel de plástico con una broca de 7.0 mm (9/32"). Repita para las ocho (8) ubicaciones de placa posterior.

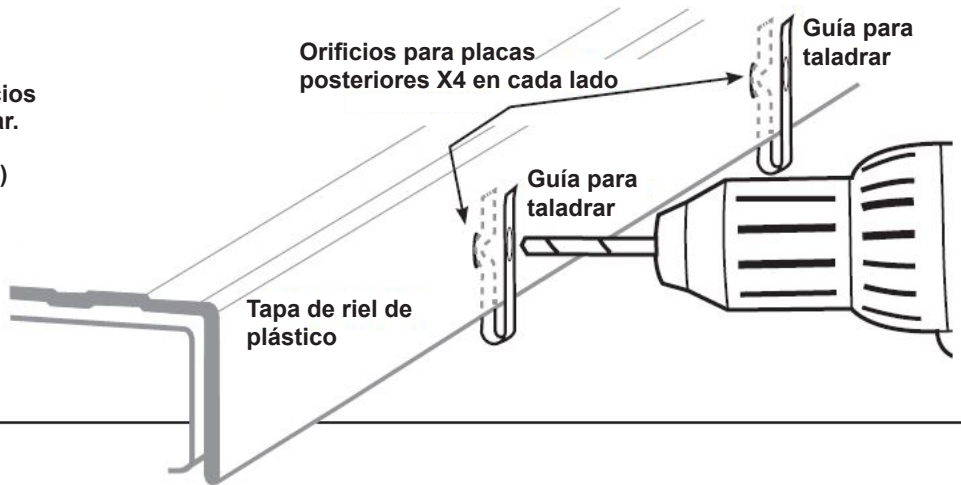

Instalación de riel lateral:

Paso 5: El riel del lado del conductor (A) tiene tres (3) muescas. El riel del lado del pasajero (B) tiene dos (2) muescas.

Instale el riel del lado del conductor (A) en el orden que se muestra. Apriete a mano el perno de fijación 1 y 2 en las tuercas de caja. Apriete a mano 3, 4, 5 y 6 en las placas posteriores. Alinee el borde del sello del riel con la parte superior de la tapa decorativa de plástico como se muestra en la figura A. Use destornillador Torx T30 para apretar completamente los pernos 3, 4, 5 y 6 seguidos por los pernos 1 y 2 a 8.7 N-m. Repita para el riel del lado del pasajero (B).

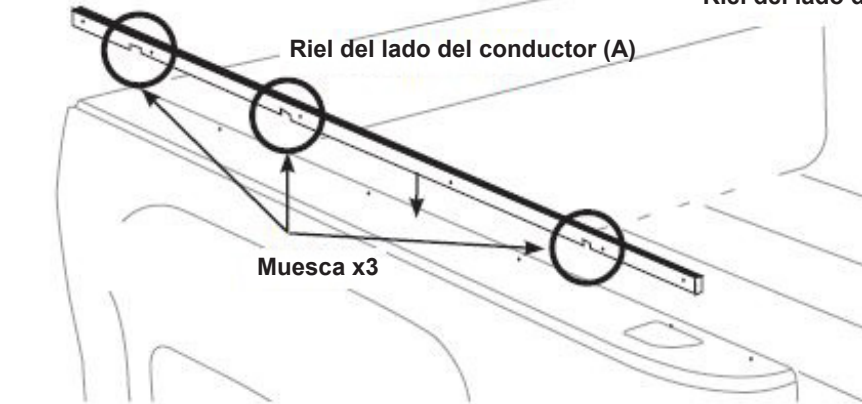
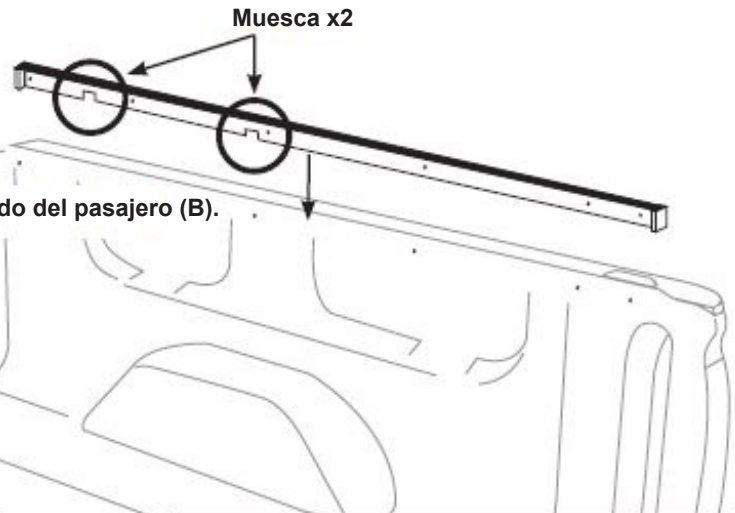

Las placas posteriores van instaladas en el lado de atrás de la lámina. NO instale las placas posteriores entre las tapas decorativas de plástico y la lámina.

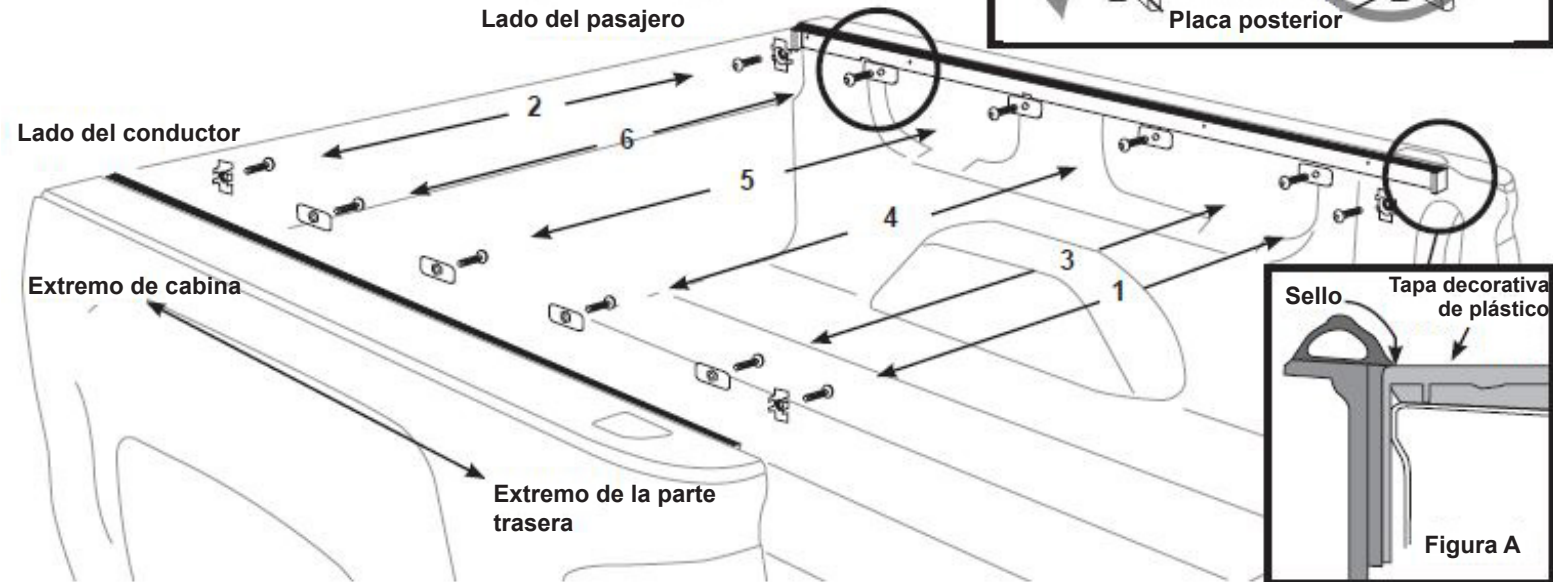

Instalación de cubierta:

Paso 6:

Localice la muesca en los rieles del lado del conductor y del pasajero que esté más cerca de la pared de cabina de la caja de la camioneta. Alinee las abrazaderas estacionarias con la muesca. Posicione la cubierta en forma uniforme entre un lado y otro y coloque el sello de cabina suavemente a lo largo de la pared de cabina de la caja. Posicione las abrazaderas estacionarias de modo que el gancho se envuelva alrededor de la lámina. Apriete la tuerca. Asegúrese de apretar cada lado en forma uniforme. Apriete hasta que el gancho de la abrazadera haga contacto con la lámina, luego apriete dos (2) vueltas más a 8.7 N-m. NO sujete la abrazadera estacionaria a la tapa decorativa de plástico o al revestimiento de la caja. NO apriete en exceso.

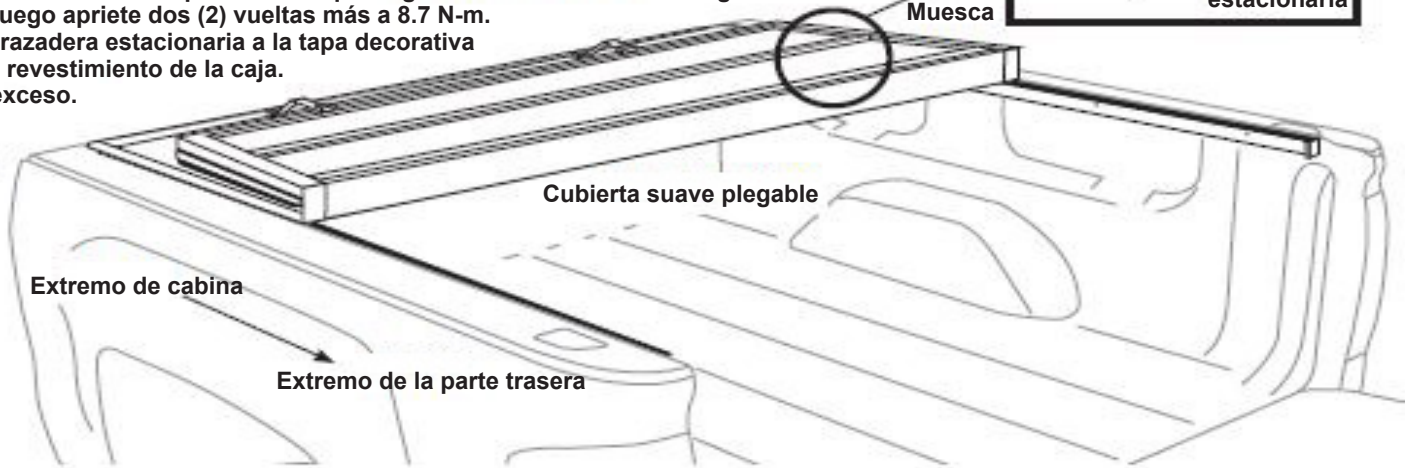

Paso 7:

Desenganche las correas de amarre y desdoble la cubierta.

Instalación de cubierta

Paso 8:

Con ambas manos, oprima la barra trasera hasta que los cierres de resbalón traseros enganchen en los rieles del lado del conductor y del pasajero.

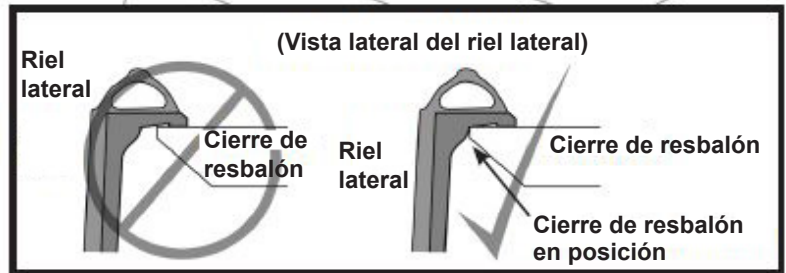
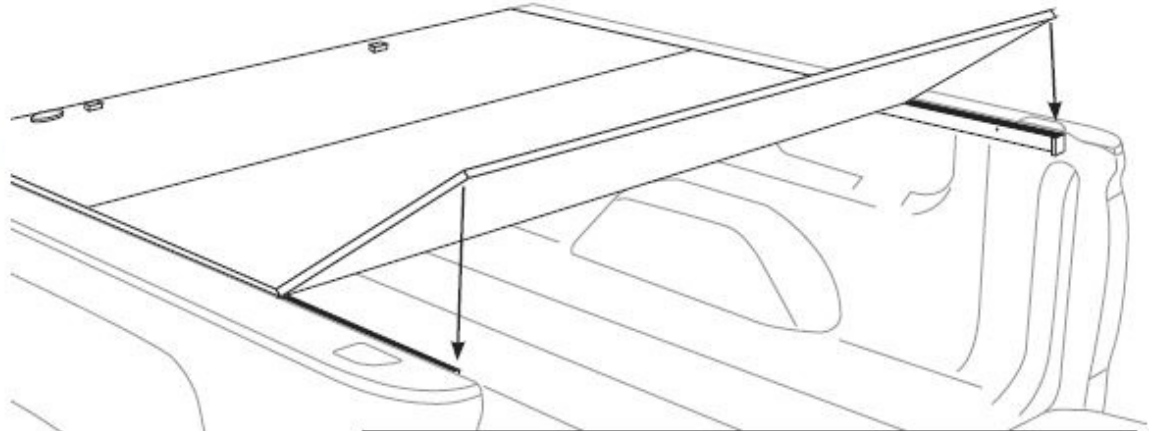

Instalación de cubierta

Paso 9 (opcional):

Si los cierres de resbalón no enganchan o hay una holgura excesiva en los cierres, ajústelos hacia adentro o hacia afuera y hacia arriba o hacia abajo. Para ajustar, afloje los cuatro (4) tornillos. Para mover los cierres hacia adentro o hacia afuera, mueva la placa de cierre metálica. Para mover los cierres hacia arriba o hacia abajo, mueva la lengüeta ajustadora de plástico. Apriete los cuatro (4) tornillos. Repita el Paso 8.

