

Splash Guard - Rear

Please read instructions thoroughly before starting.

Installation time: 30 minutes

Package Contents:

Description	Quantity
Left Hand Splash Guard	1
Right Hand Splash Guard	1
#10 x 3/4" Screw	2
#10 Spring Clip	2
#14 x 3/4" Screw	2
#14 Spring Clip	2
Instruction Sheet	1

Tools Required:

#2 Phillips Screwdriver	Center Punch
3/32" (2.5mm) Drill Bit/Drill	Drill
Hammer	Clean Cloth/Rag

Painting Instructions (optional if desired):

1. Thoroughly clean all surfaces with lacquer thinner or acetone
2. Apply a flexible primer and paint as directed by the paint manufacturer.

Installation Procedure

1. Clean and degrease body panel where splash guards are to be located.
2. Identify panel edge bolt, location A, and push pin, location C. Remove bolt and push pin, do not discard. See Figure 1.
3. Pull liner forward and install supplied spring clip over hole C. See Figures 1 and 2.
4. Position splash guard so liner passes through slot and lock tab is clipped over bumper panel edge. See Figures 1 and 3.
5. While holding splash guard firmly against panel, install existing bolt, location A, and supplied screw, location C. See Figure 1.
6. While holding splash guard firmly against panel, mark and drill center pilot hole in location B. See Figure 1.
7. While holding splash guard firmly against panel, install supplied screw in location B. Do not over tighten.
8. Install locking spring clip on inside of bumper panel edge behind lock tab, while holding splashguard as far rearward as possible.
9. Repeat procedure for other side.
10. Guards can be cleaned with any commercially available cleaner.

FIGURE 1

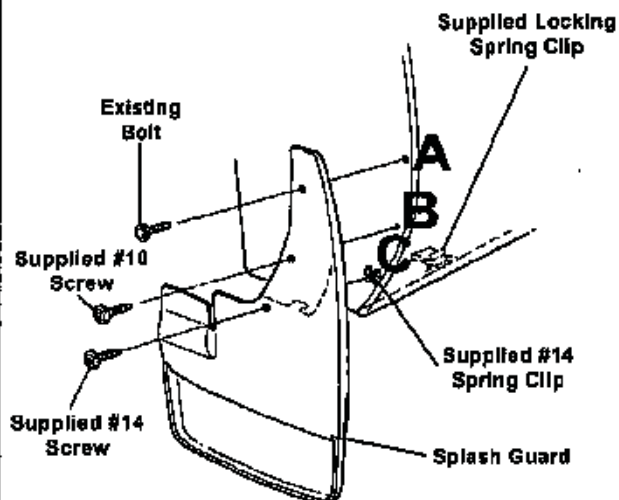
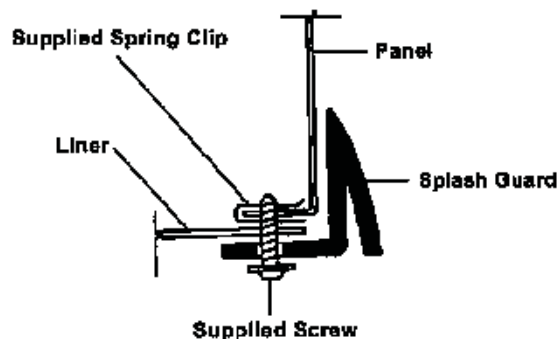

FIGURE 2



NOTE: INSTALL SUPPLIED SPRING CLIPS WITH TURNED UP EDGE ON INSIDE OF PANEL EDGE.

FIGURE 3

