

Air Cleaner Kit Installation

[Installation Instructions Part Number](#)

84659729

Thank you for choosing Chevrolet Performance as your high performance source. Chevrolet is committed to providing proven, innovative performance technology that is truly more than just power. Chevrolet Performance air inlet systems are engineered, developed and tested to exceed your expectations for fit and function. Please visit our website at www.chevroletperformance.com.

This publication provides general information on components and procedures that may be useful when installing a Chevrolet Corvette air induction system. Please read the entire publication before starting work. Observe all safety precautions and warnings in the service manuals when installing the Chevrolet Corvette intake system on your vehicle. Wear eye protection and appropriate protective clothing. When working under or around the vehicle support it securely with jack stands. Use only the proper tools. Exercise extreme caution when working with flammable, corrosive and hazardous liquids and materials. Some procedures require special equipment or skills. If you do not have the appropriate training, expertise and tools to perform any part of the installation safely, this work should be done by a professional

Please read this entire publication before starting work. Also, please verify that all of the components listed in the Package Contents section below were shipped in the kit. The information below is divided into the following sections: Package contents and installation instructions. It is not the intent of these specifications to replace the comprehensive and detailed service practices explained in the GM service manuals. For detailed installation instructions please look to the service manual for your specific vehicle.

GM service manuals are available from: Helm Incorporated PO Box 07130 Detroit, MI 48207

For information about warranty coverage, please contact your local Chevrolet Performance parts dealer.

Observe all safety precautions and warnings in the service manuals when installing this kit in any vehicle. Wear eye protection and appropriate protective clothing. Support the vehicle securely with jack stands when working under or around it. Use only the proper tools. Exercise extreme caution when working with flammable, corrosive, and hazardous liquids and materials. Some procedures require special equipment and skills. If you do not have the appropriate training, expertise, and tools to perform any part of this conversion safely, this work should be done by a professional.

The information contained in this publication is presented without any warranty. All the risk for its use is entirely assumed by the user. Specific component design, mechanical procedures and the qualifications of the individual readers are beyond the control of the publisher, and therefore the publisher disclaims all liability incurred in connection with the use of the information provided in this publication.

Chevrolet, Chevy, the Chevrolet Bow Tie Emblem, General Motors, and GM are all Registered Trademarks of the General Motors Corporation.

Kit Contents

Qty	Description
1	Performance Airbox Assembly
1	Wiring hold down strap
1	Hose Abrasion Protection kit

© 2019 General Motors. All rights reserved.

Qty	Description
2	Cooling line management tie straps for ZR1
1	Chevrolet Performance Emblem
1	EO Label
1	Installation Instructions

Tools Required

- 7mm, 8mm, 10mm sockets, socket drive extension
- Flat Head Screwdriver
- Phillips Head Screwdriver
- Sidecutters
- Masking Tape

Fastener Caution

Caution: Use the correct fastener in the correct location. Replacement fasteners must be the correct part number for that application. Do not use paints, lubricants, or corrosion inhibitors on fasteners, or fastener joint surfaces, unless specified. These coatings affect fastener torque and joint clamping force and may damage the fastener. Use the correct tightening sequence and specifications when installing fasteners in order to avoid damage to parts and systems. When using fasteners that are threaded directly into plastic, use extreme care not to strip the mating plastic part(s). Use hand tools only, and do not use any kind of impact or power tools. Fastener should be hand tightened, fully seated, and not stripped.

Battery Disconnect Warning

Warning: Unless directed otherwise, the ignition must be OFF with the key removed, and all electrical loads must be OFF before servicing any electrical component. Disconnect the negative battery cable to prevent an electrical spark should a tool or equipment come in contact with an exposed electrical terminal. Failure to follow these precautions may result in personal injury and/or damage to the vehicle or its components.

Warning: For Vehicles equipped with OnStar® (UE1) with Back Up Battery: The Back Up Battery is a redundant power supply to allow limited OnStar® functionality in the event of a main vehicle battery power disruption to the VCIM (OnStar® module). Do not disconnect the main vehicle battery or remove the OnStar® fuse with the ignition key in any position other than OFF. Retained accessory power should be allowed to time out or be disabled (simply opening the driver door should disable retained accessory power) before disconnecting power. Disconnecting power to the OnStar® module in any way while the ignition is On or with retained accessory power activated may cause activation of the OnStar® Back-Up Battery system and will discharge and permanently damage the back-up battery. Once the Back-Up Battery is activated it will stay on until it has completely discharged. The back-up battery is not rechargeable and once activated the back-up battery must be replaced.

Diesel/Gasoline Vapors Warning

Warning: Fuel/gasoline vapors are highly flammable. A fire could occur if an ignition source is present. Never drain or store gasoline or diesel fuel in an open container, due to the possibility of fire or explosion. Have a dry chemical (Class B) fire extinguisher nearby.

Fuel Pressure Relief Warning

Warning: Fuel that flows out at high pressure can cause serious injury to the skin and eyes. ALWAYS depressurize the fuel system before removing components that are under high fuel pressure.

Warning: Remove the fuel tank cap and relieve the fuel system pressure before servicing the fuel system in order to reduce the risk of personal injury. After you relieve the fuel system pressure, a small amount of fuel may be released when servicing the fuel lines, the fuel injection pump, or the connections. In order to reduce the risk of personal injury, cover the fuel system components with a shop towel before disconnection. This will catch any fuel that may leak out. Place the towel in an approved container when the disconnection is complete.

Safety Glasses Warning

Warning: Wear safety glasses in order to avoid eye damage.

Preparation

Remove all contents from their packaging. Ensure there are no debris or foreign object in the airbox assembly prior to install.

Procedure

1. Floor Trim Cover Removal:

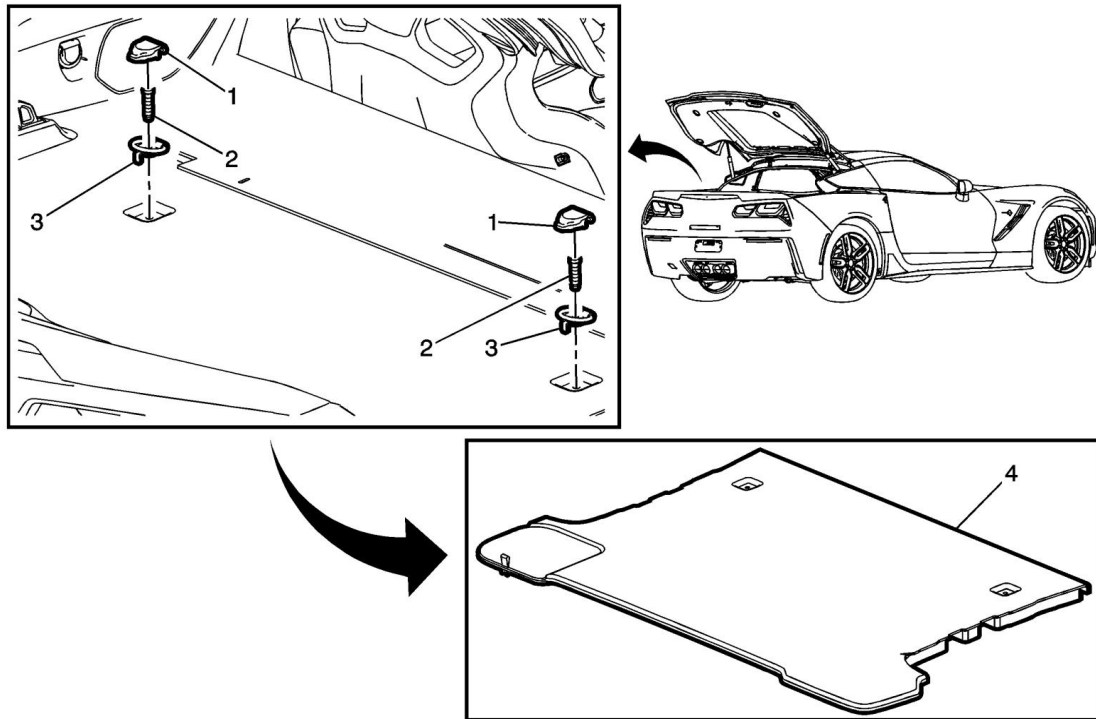

- 1.1. Remove cargo tie down loop bolt cap (1).
- 1.2. Remove cargo tie down loop fastener (2).
- 1.3. Remove cargo tie down loop assembly (3).
- 1.4. Remove rear compartment floor panel trim (4):
 - 1.4.1. Release the retainers in the left rear corner.
 - 1.4.2. At radio rear compartment speaker, insert hand under rear edge of carpet and lift up to slide carpet out from under the adjoining trim panels.

2. Battery Negative Cable Disconnection:

© 2019 General Motors. All rights reserved.

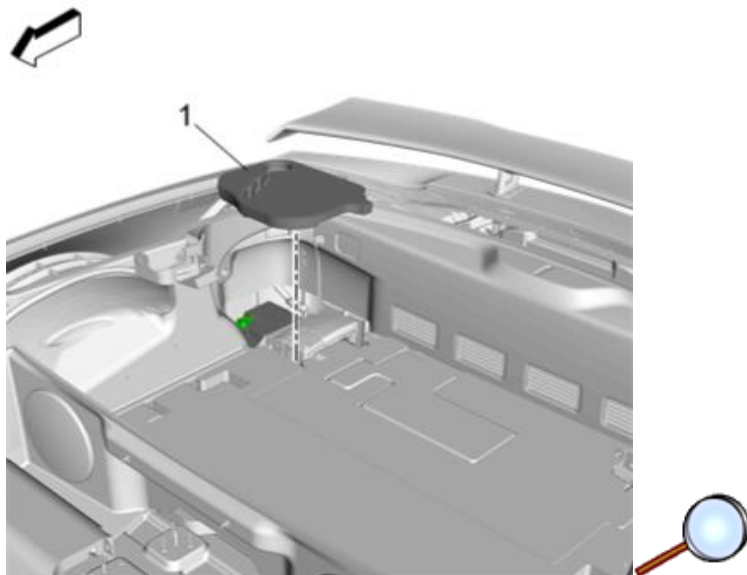

2.1. Remove the floor panel carpet support (1) from the top of the battery.

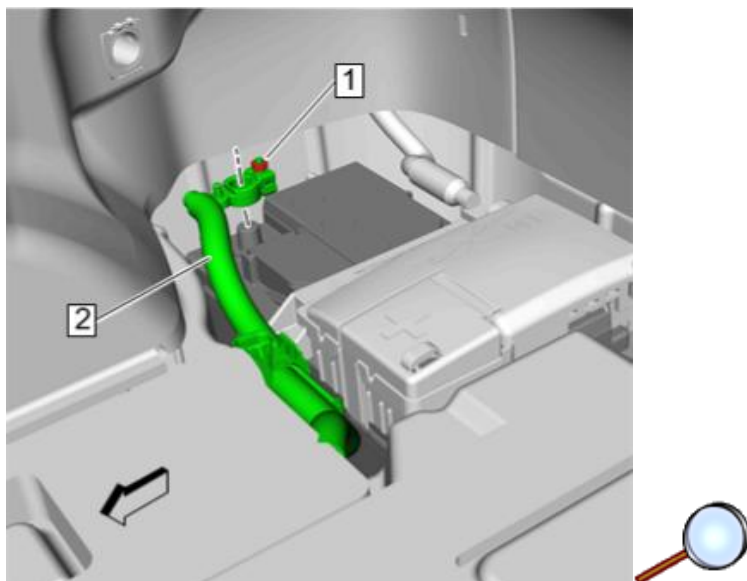

Warning: Before servicing any electrical component, the ignition key must be in the OFF or LOCK position and all electrical loads must be OFF, unless instructed otherwise in these procedures. If a tool or equipment could easily come in contact with a live exposed electrical terminal, also disconnect the negative battery cable. Failure to follow these precautions may cause personal injury and/or damage to the vehicle or its components.

2.2. Loosen the battery negative cable clamp fastener (1) and remove the battery negative cable (2) from the battery negative post.

3. Intake Manifold Cover Removal (For ZR1 Only, for other variants continue to step 4):

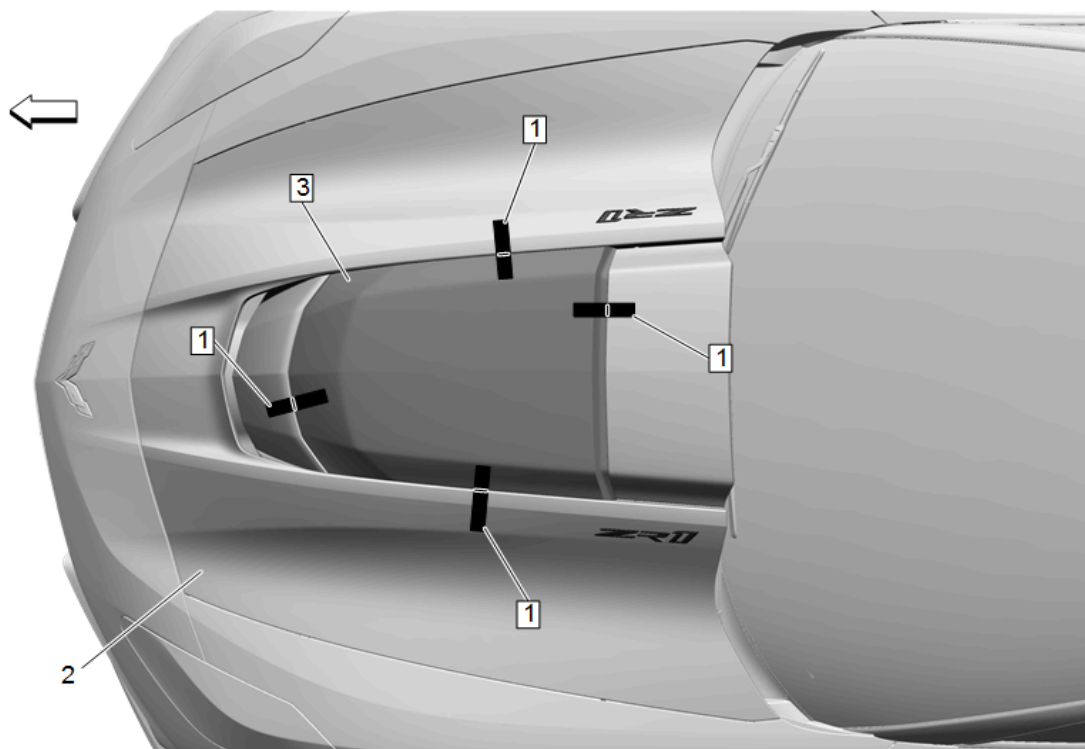

- 3.1. Use masking tape (1) to mark the location of the intake manifold cover (3) and the hood (2) as shown. Carefully cut the tape between the hood and intake manifold cover.
- 3.2. Open the hood.

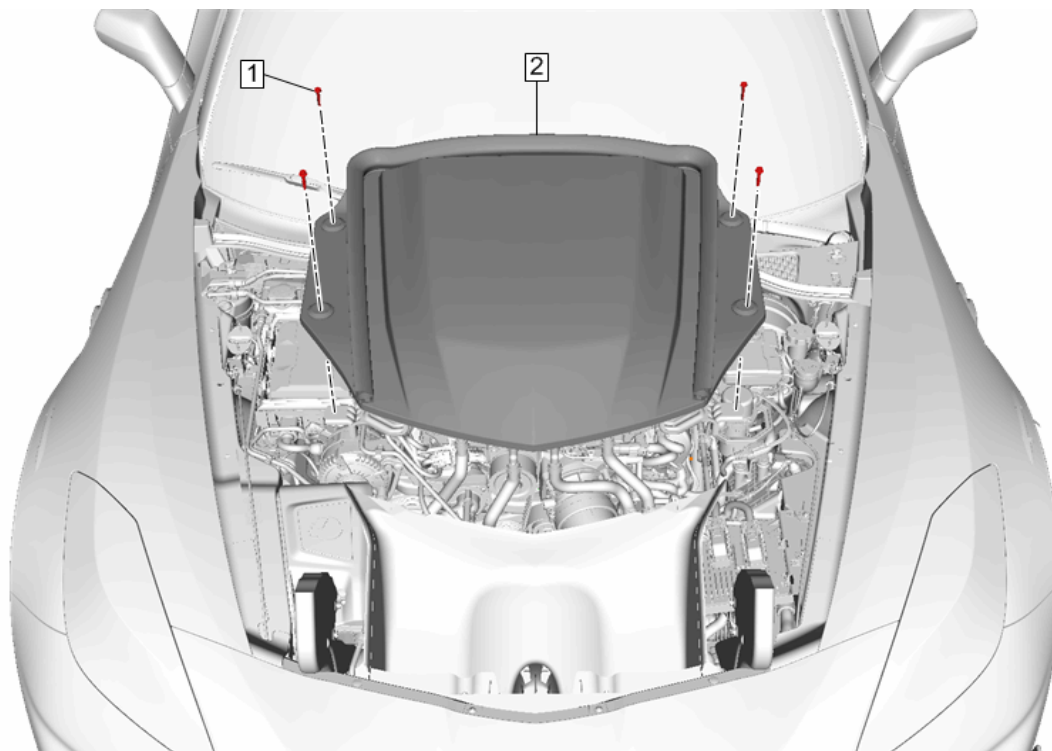

- 3.3. Remove the intake manifold cover bolts (1) (Qty: 4).
- 3.4. Carefully remove the intake manifold cover (2).

© 2019 General Motors. All rights reserved.

4. Radiator Air Upper Baffle Extension Removal:

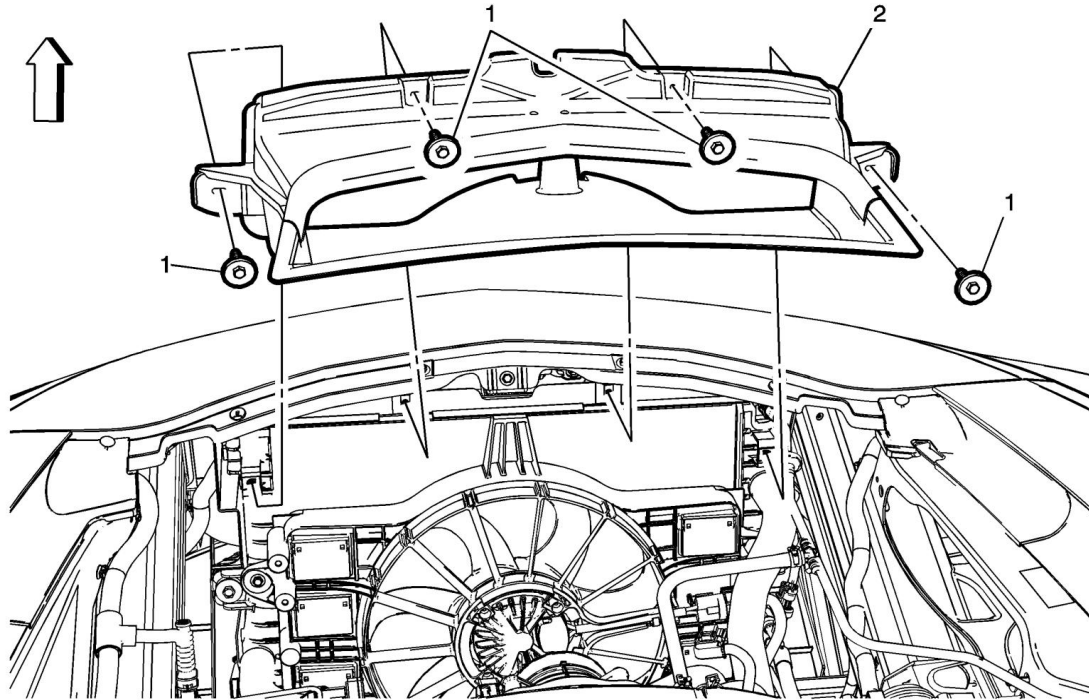

- 4.1. Stingray, Grand Sport and Z06: Remove the radiator air upper baffle extension bolts (1).
 4.2. Remove the radiator air upper baffle extension (2).

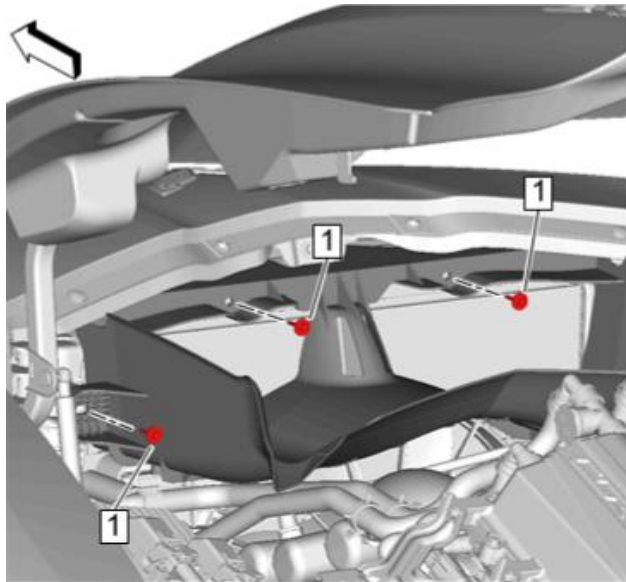

- 4.3. ZR1: Remove the radiator air upper baffle extension bolts (1).

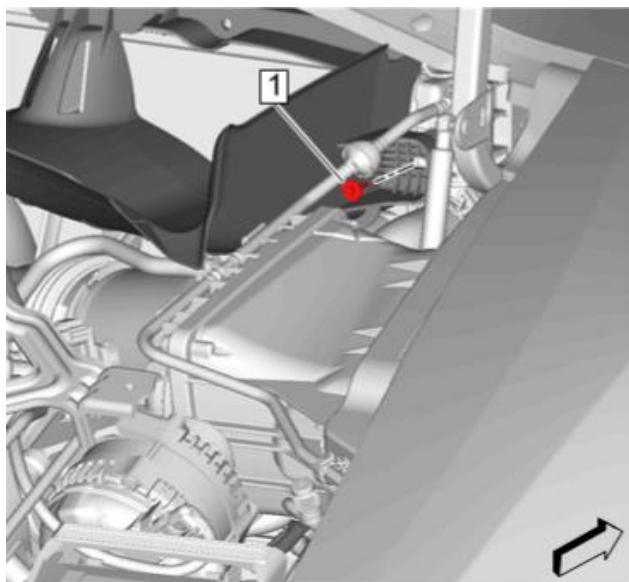

4.4. Remove the radiator air upper baffle extension bolt (1).

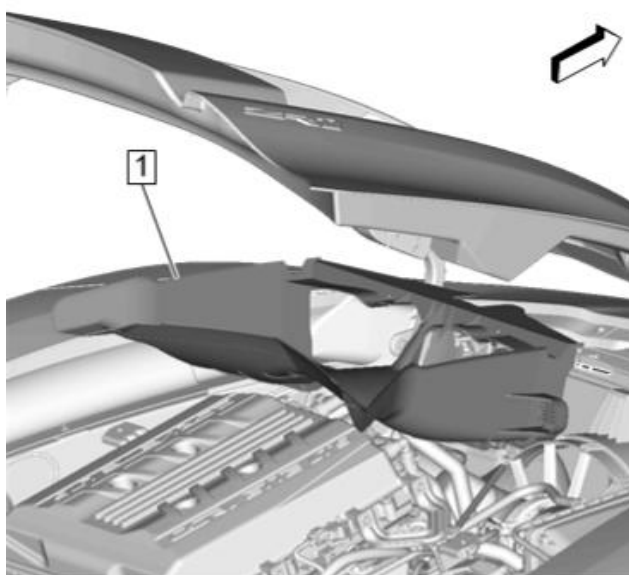

4.5. Remove the radiator air upper baffle extension (1).

5. Disconnect PCV Connections:

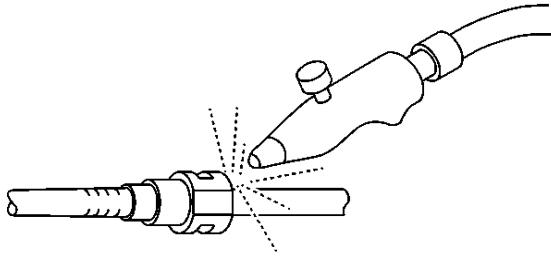

5.1. Using compressed air, blow any dirt or debris from around the connection.

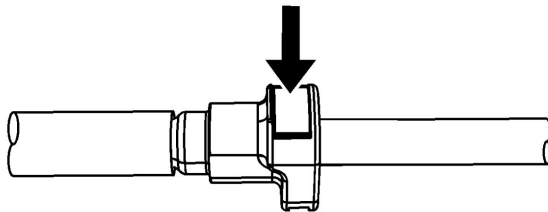

5.2. This step applies to the push down TI style connector ONLY. Release the fitting by pressing on the tab indicated by the arrow.

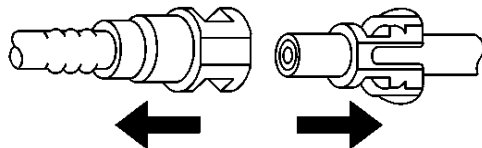

5.3. Pull the connection apart.

Locate PCV Fitting:

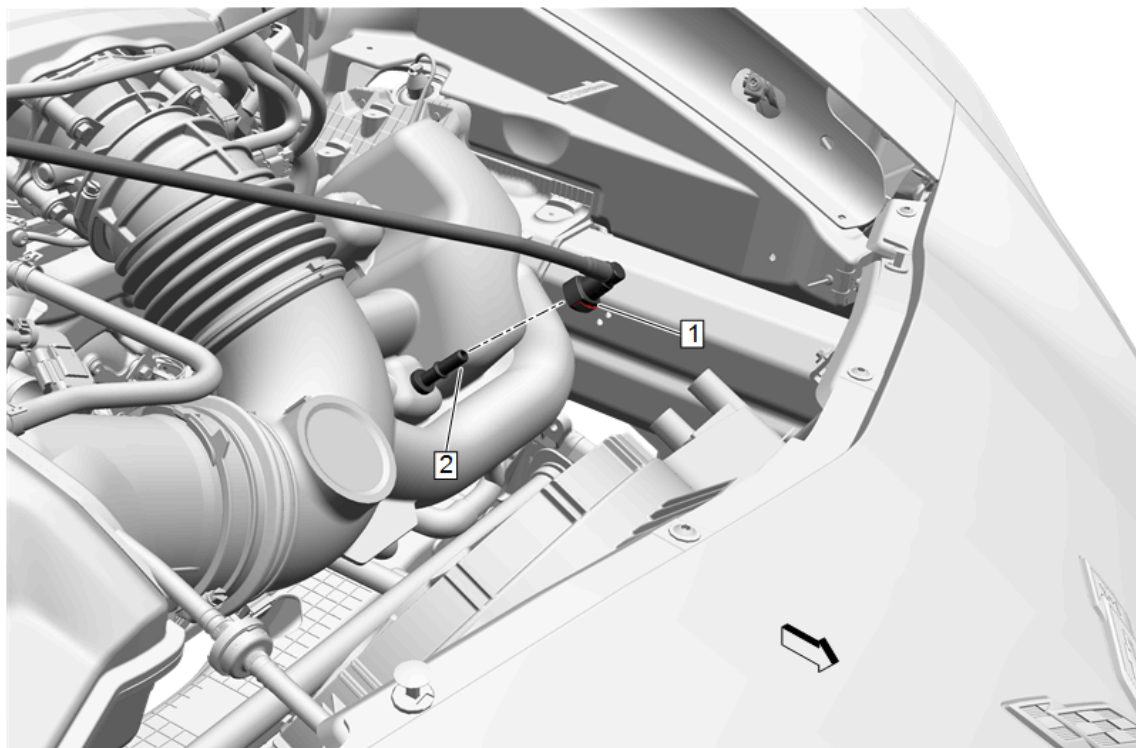

5.3.1. Stingray and Grand Sport: Disconnect PCV fitting (1) from air cleaner outlet duct (2).

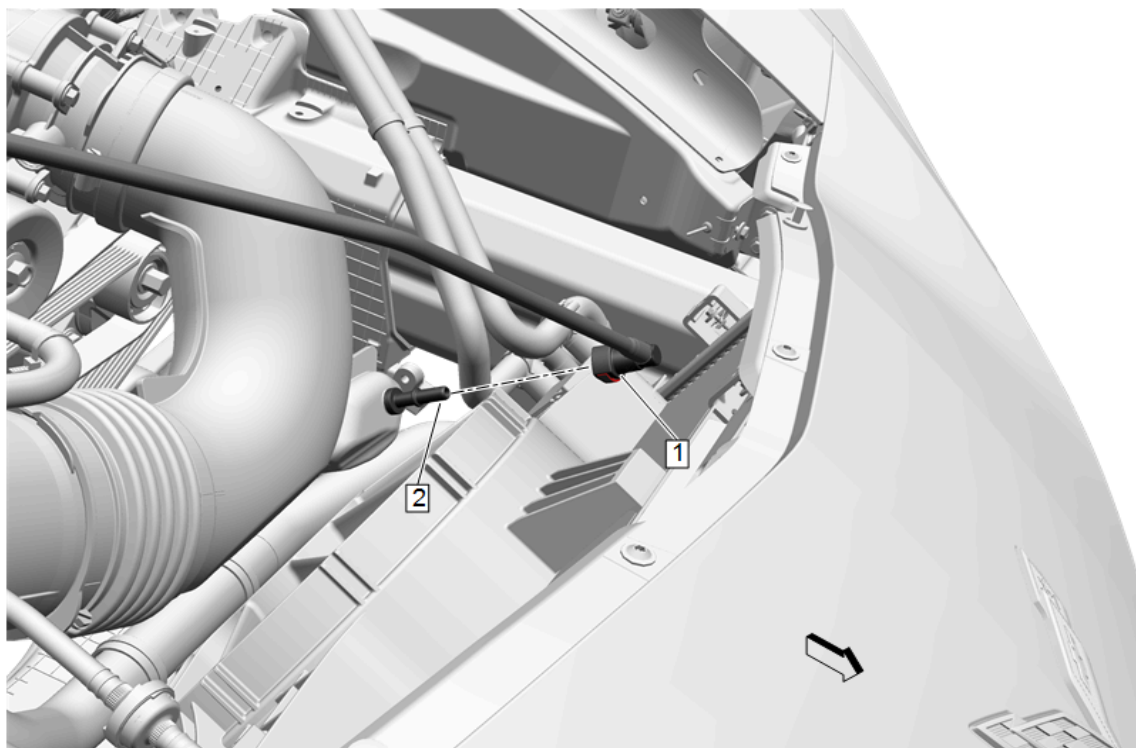

5.3.2. ZO6: Disconnect PCV fitting (1) from air cleaner outlet duct (2).

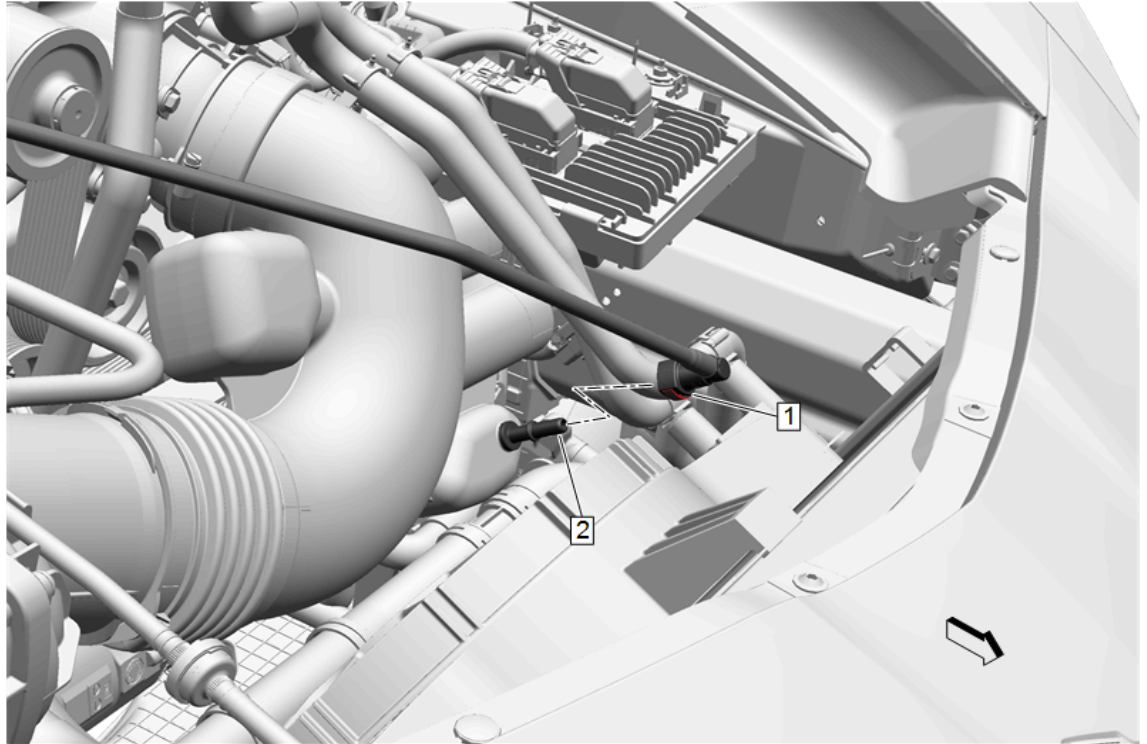

5.3.3. ZR1: Disconnect PCV fitting (1) from air cleaner outlet duct (2).

6. Air Cleaner Duct Removal:

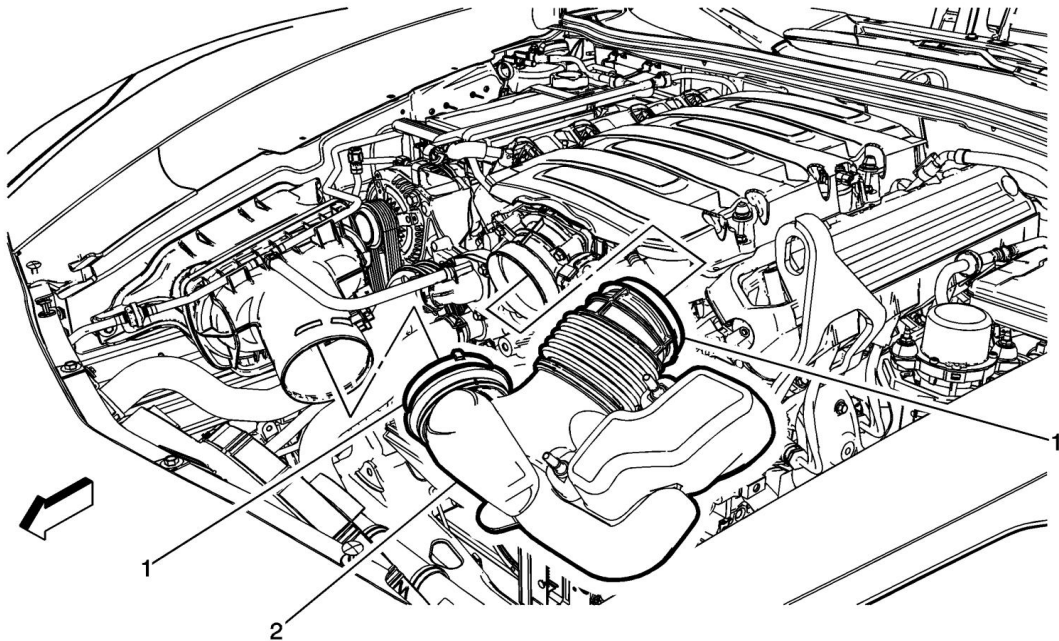

6.1. Stingray and Grand Sport: Loosen the air cleaner outlet duct clamps (1) at throttle body and air cleaner. Remove air cleaner outlet duct (2).

© 2019 General Motors. All rights reserved.

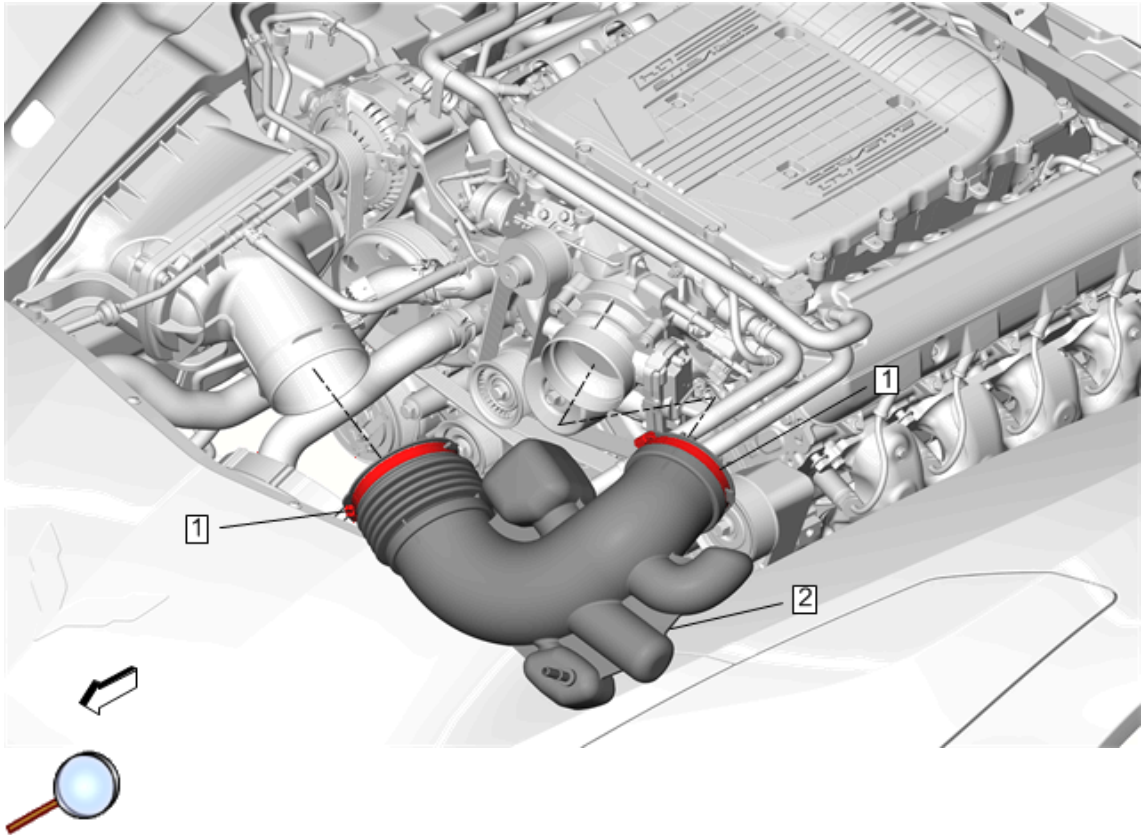

- 6.2. Z06: Loosen the air cleaner outlet duct clamps (1) at throttle body and air cleaner. Remove air cleaner outlet duct (2).

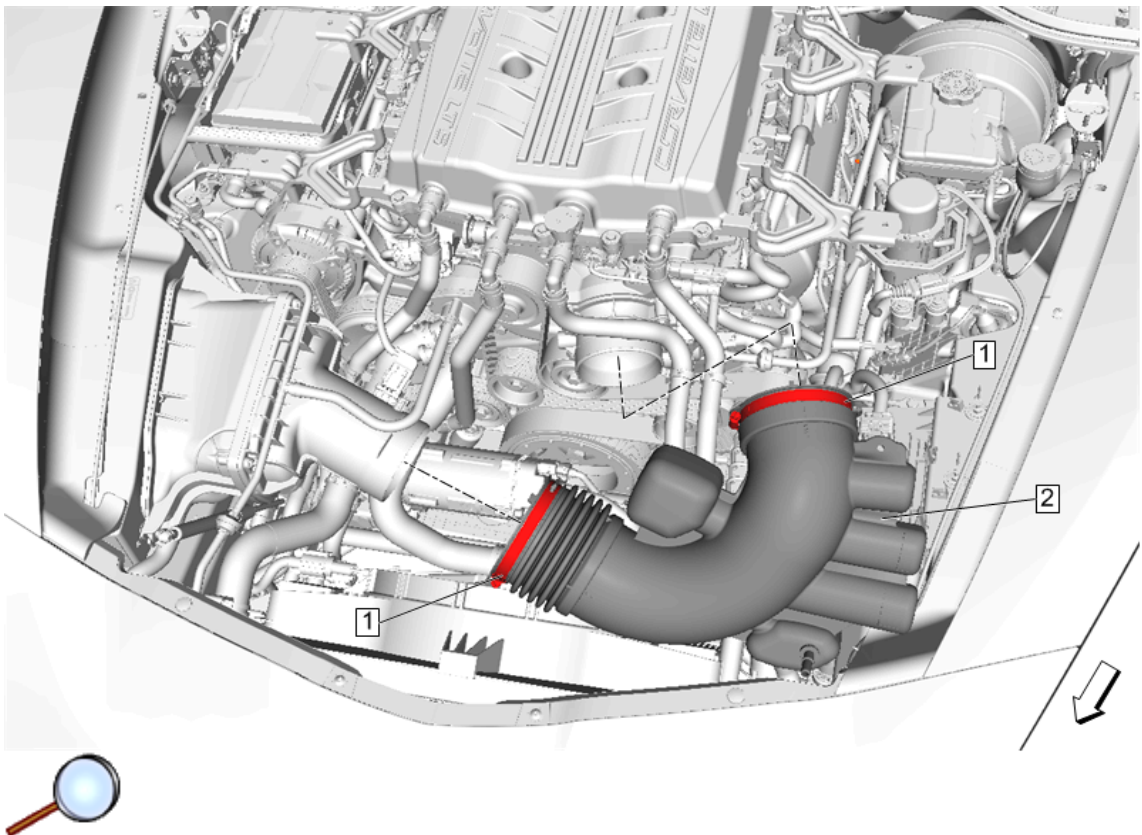

- 6.3. ZR1: Loosen the air cleaner outlet duct clamps (1) at throttle body and air cleaner. Remove air cleaner outlet duct (2).

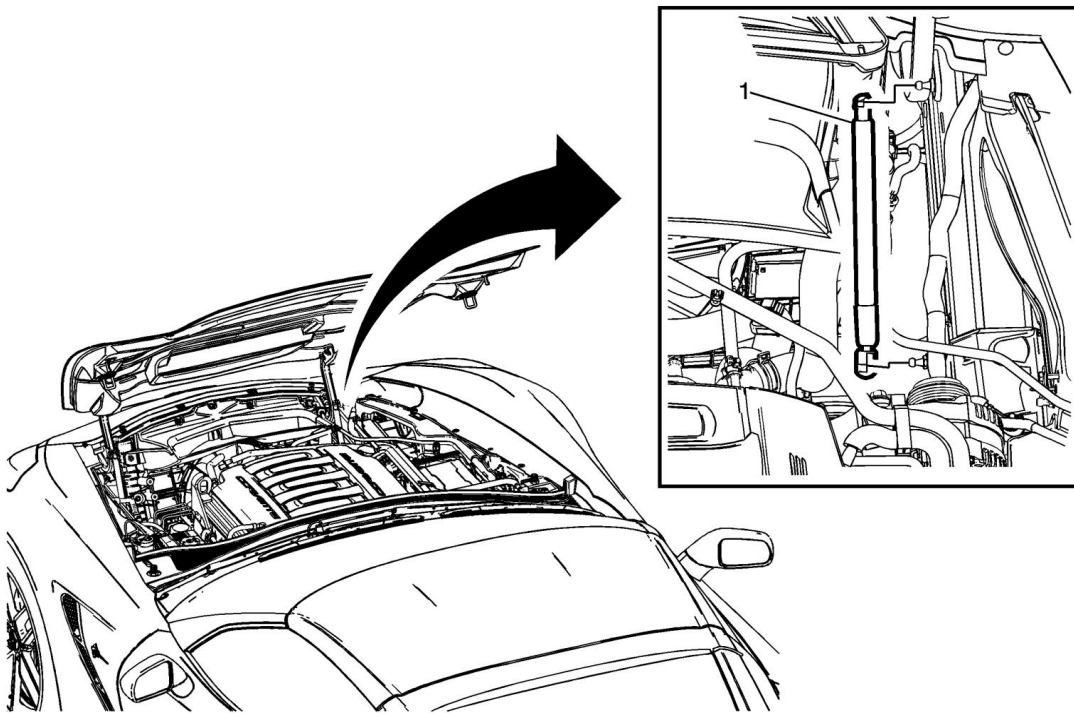

Warning: When a hood hold open device is being removed or installed, provide alternate support to avoid the possibility of damage to the vehicle or personal injury.

Caution: Apply pressure only at the end of the liftgate/hood assist rod that you are removing or attaching. Do NOT apply pressure to the middle of the rod because damage or bending will result.

7. Disconnect Hood Strut (1): Use a small flat-bladed tool to release the metal tabs holding the strut rod to the assist rod ball studs.
8. Remove Air Cleaner:

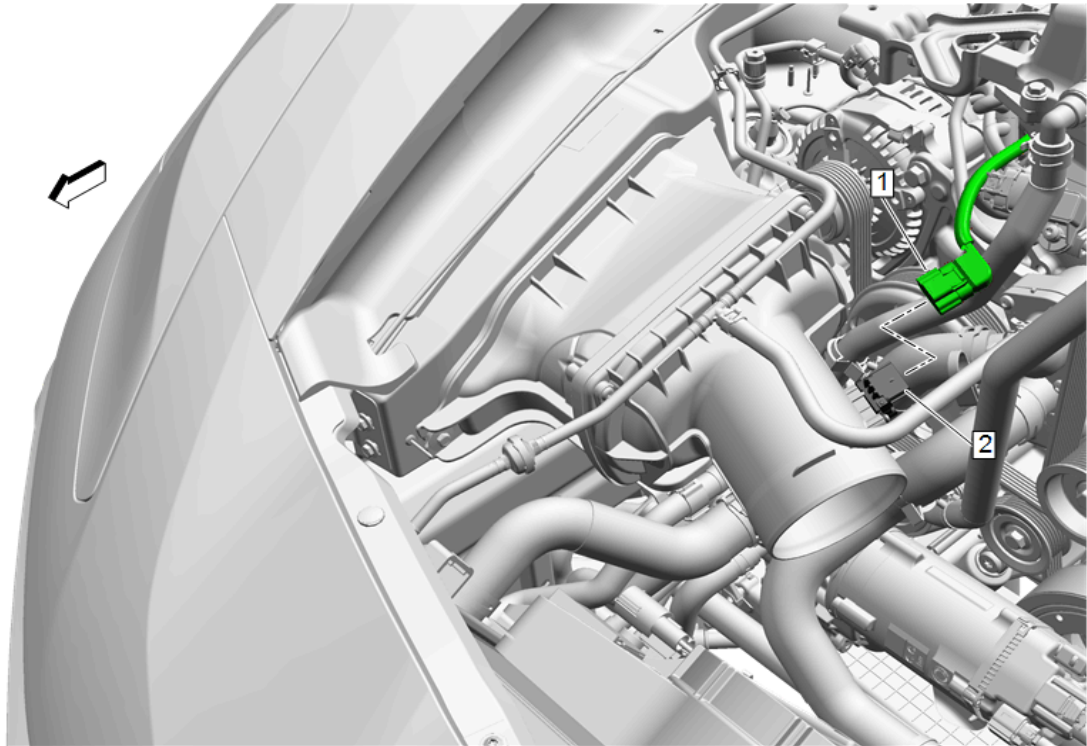

- 8.1. Pull the red positive retaining tab and disconnect the MAF sensor connector (1) from the MAF sensor (2).

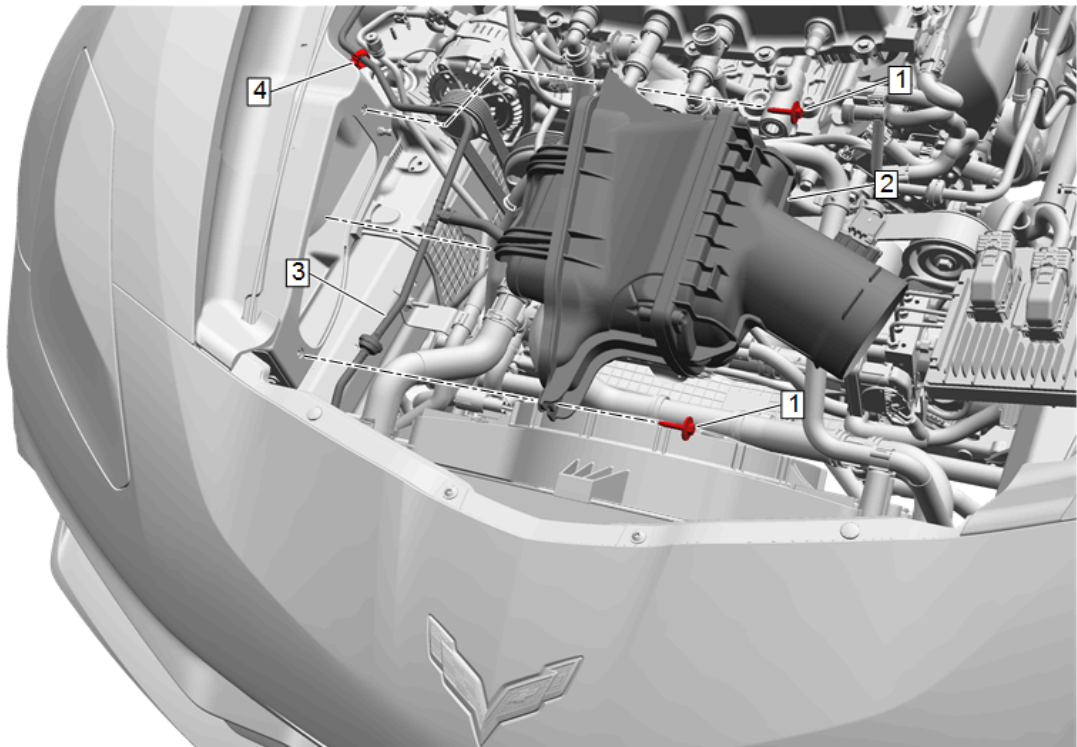

- 8.2. Remove and retain the air cleaner assembly fasteners (1).
- 8.3. Carefully lift the surge tank coolant hose (3) from both hose retainers on the air cleaner assembly, open retaining clip (4) on fender and position surge tank coolant hose to the side.

© 2019 General Motors. All rights reserved.

8.4. Carefully remove the air cleaner assembly (2).

9. Remove MAFS from Air Cleaner Assembly:

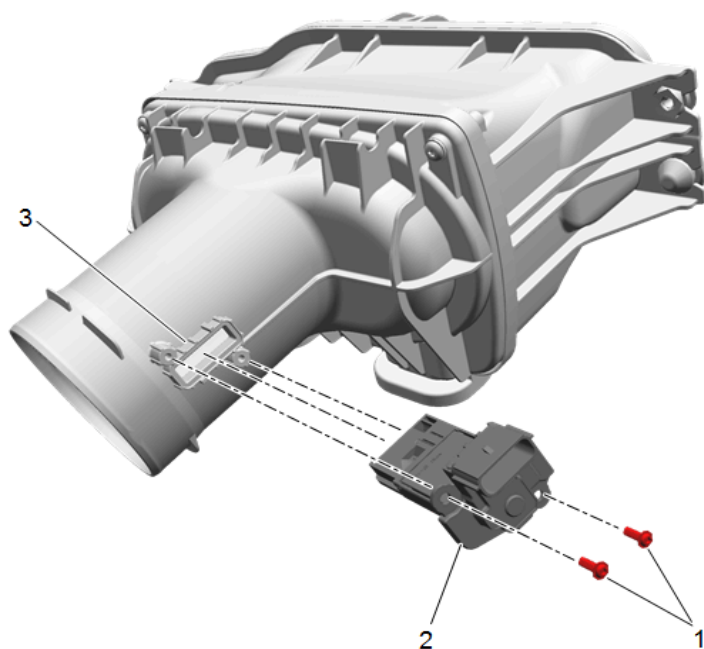

9.1. Remove and retain the screws (1) securing the MAFS (2) to the air cleaner assembly (3).

9.2. Remove the MAFS (2) from the air cleaner assembly (3).

10. Install MAFS to Performance Air Cleaner Assembly:

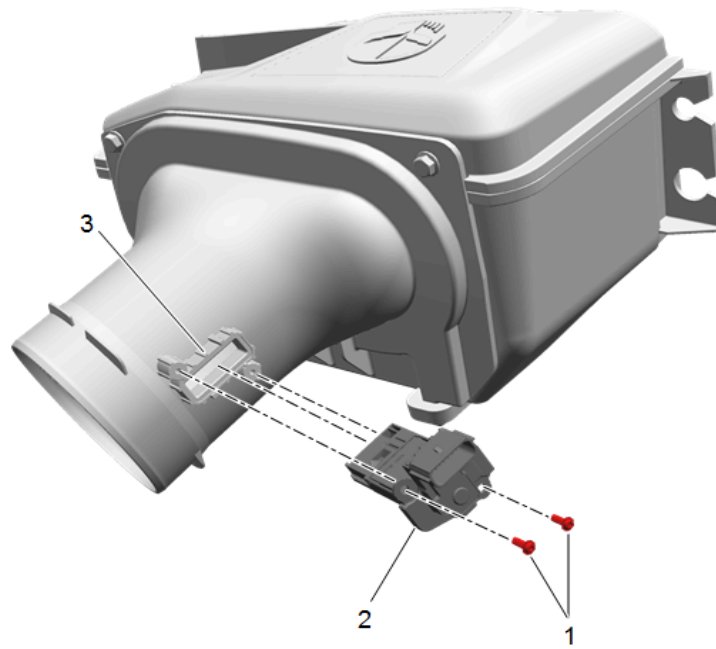

10.1. Install the MAFS (2) to the performance air cleaner assembly (3).

10.2. Secure the MAFS with the previously retained screws (1). Tighten screws to 4 N.m (35 lb in).

11. Transfer Grommets:

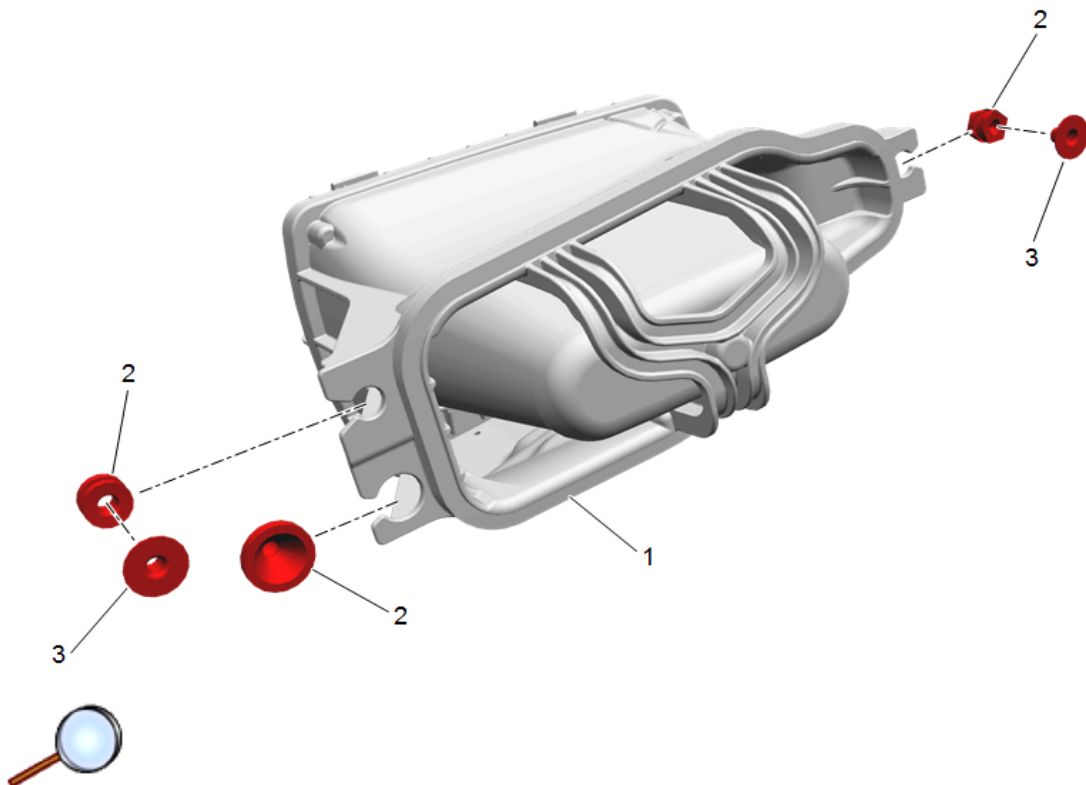

11.1. Remove metal spacer (3) from grommet (2).

11.2. Remove grommets (2) from production air cleaner assembly (1).

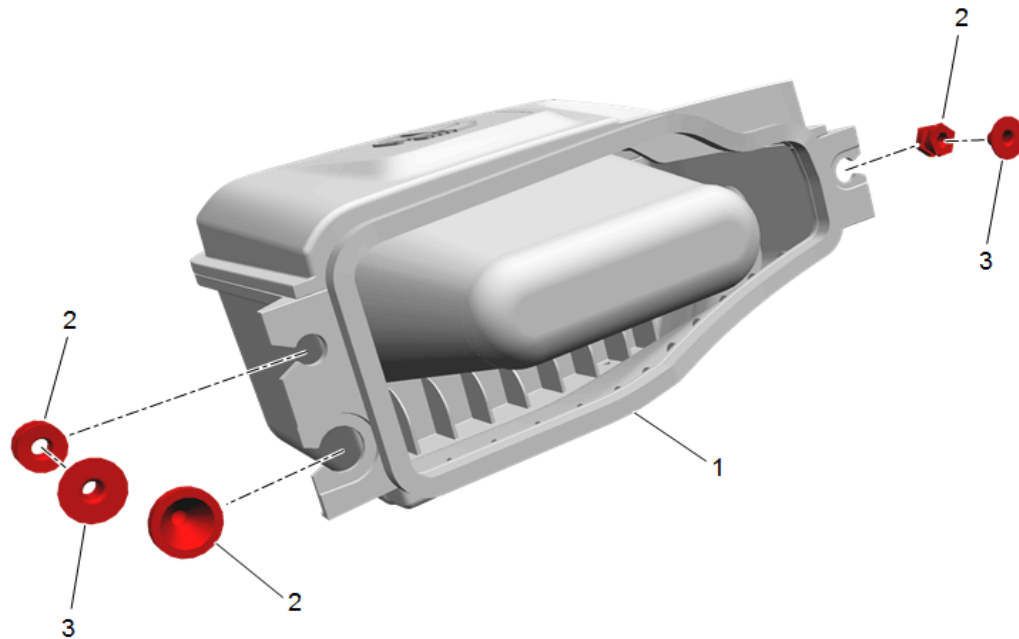

11.3. Install grommets (2) to performance air cleaner assembly (1).

11.4. Install metal spacer (3) to grommet (2).

12. Remove and Replace Front Headlamp Harness Strap:

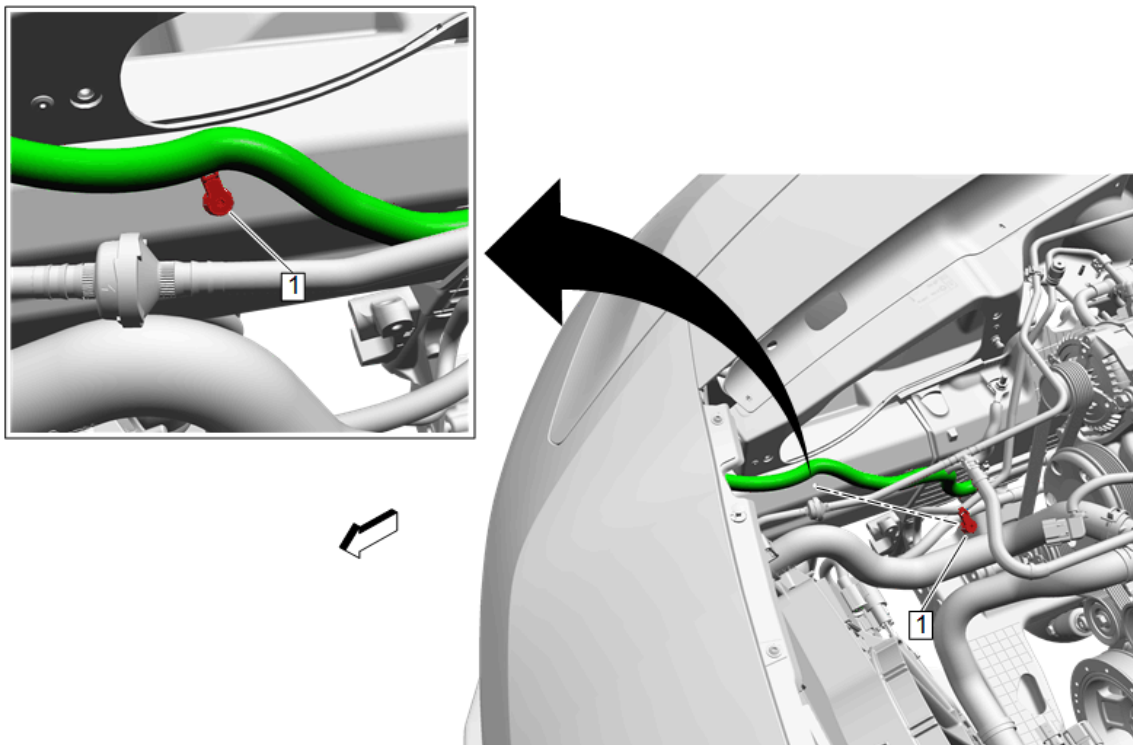

12.1. Locate and note the position of the front headlamp harness strap (1), then remove strap.

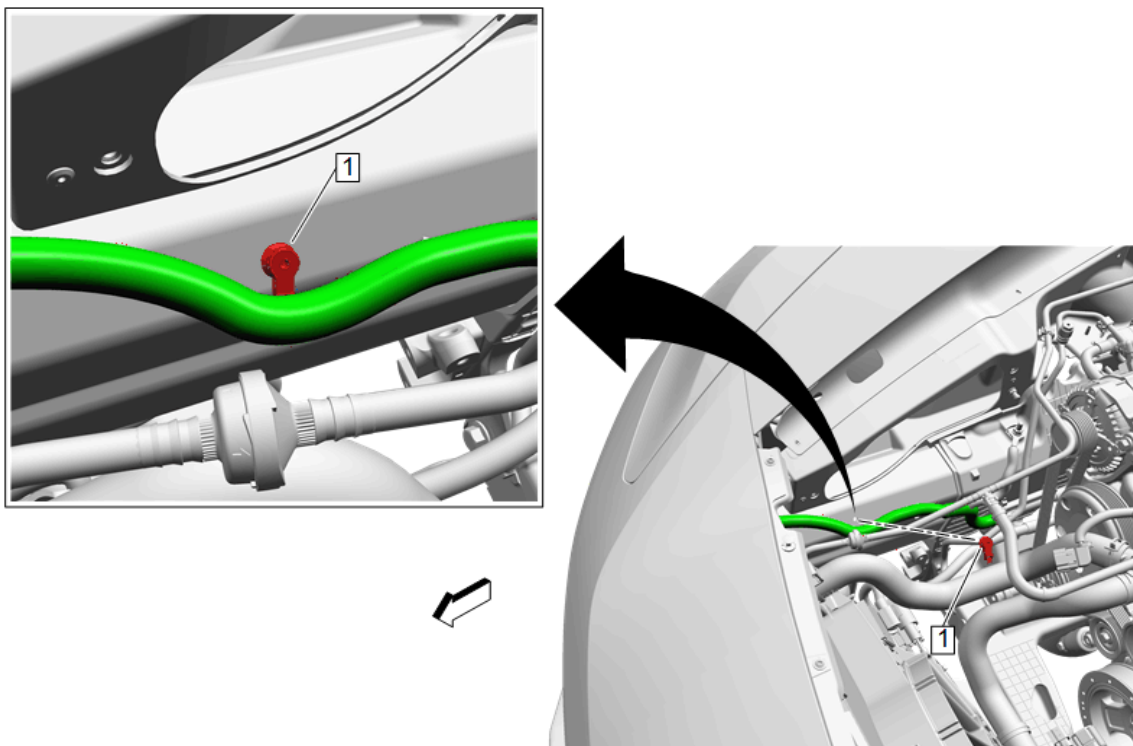

12.2. Install new headlamp harness strap (1), note the new position of strap.

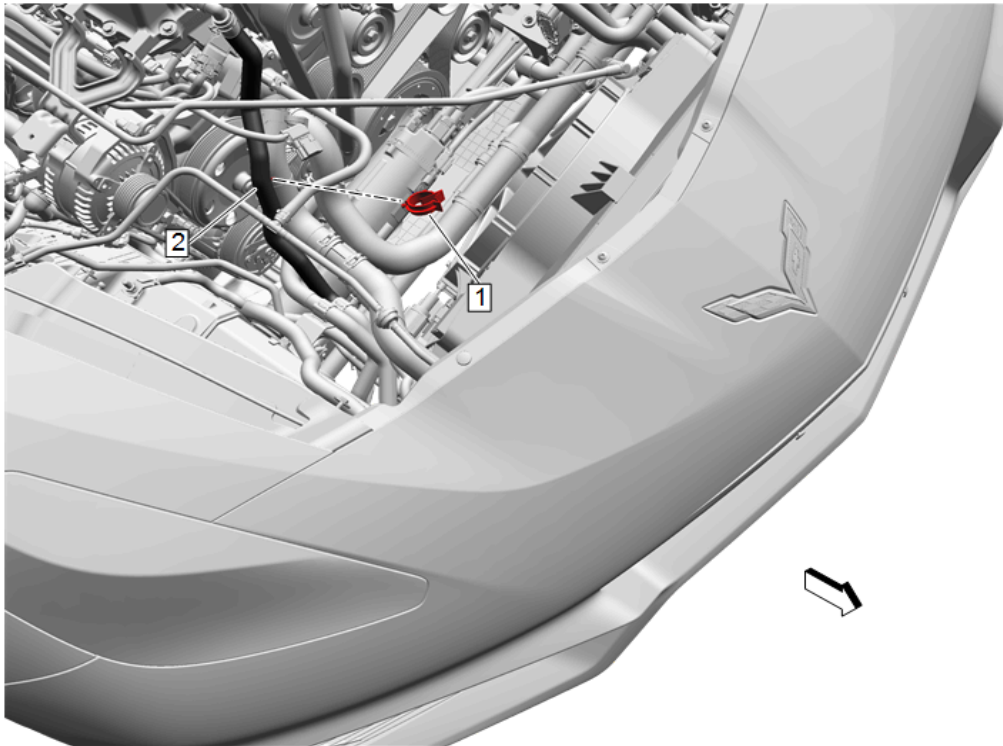

13. Remove Cooling Hose Retaining Clip (For ZR1 only, for other variants refer to step 15): Carefully remove the retaining clip (1) with a pair of side cutters. Use extreme caution to not damage the hose (2).

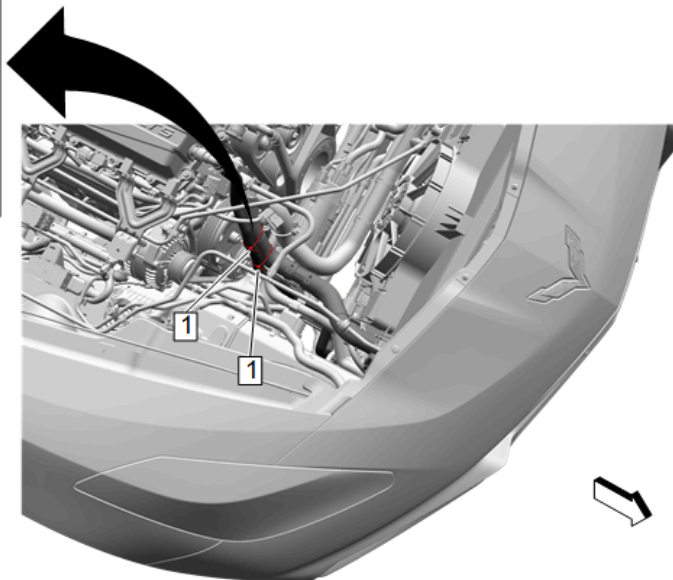
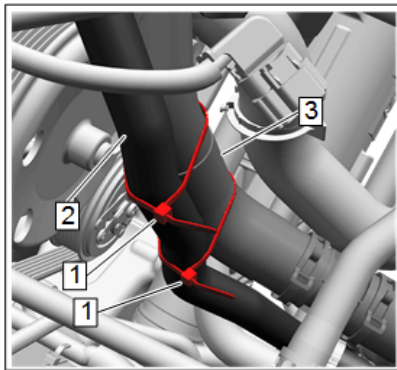

14. Install Hose Tie-Straps to the Hose (For ZR1 only, for other variants refer to step 15): Install the tie straps (1) onto the intercooler cooling hose (2) and radiator cooling hose (3) as shown.
15. Install Performance Air Cleaner Assembly:

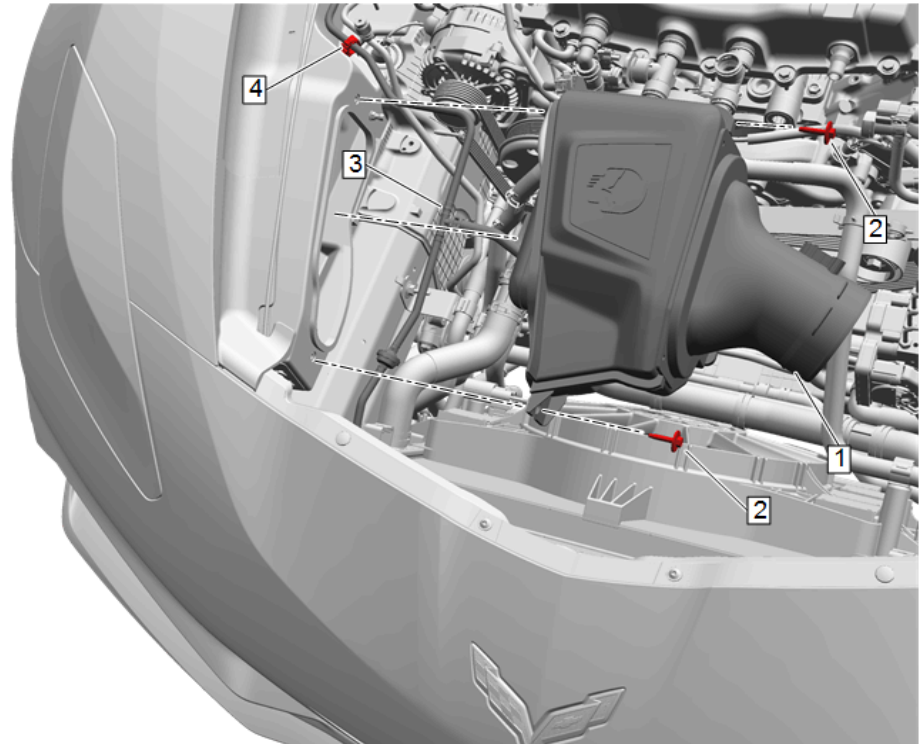

- 15.1. Carefully lift the surge tank coolant hose (3) and install the performance air cleaner assembly (1) to vehicle.
- 15.2. Install the previously retained fasteners (2) to the performance air cleaner assembly (1). Tighten the fasteners to 9 N.m (80 lb in).
- 15.3. Install surge tank coolant hose (3) back into clip (4) on fender.

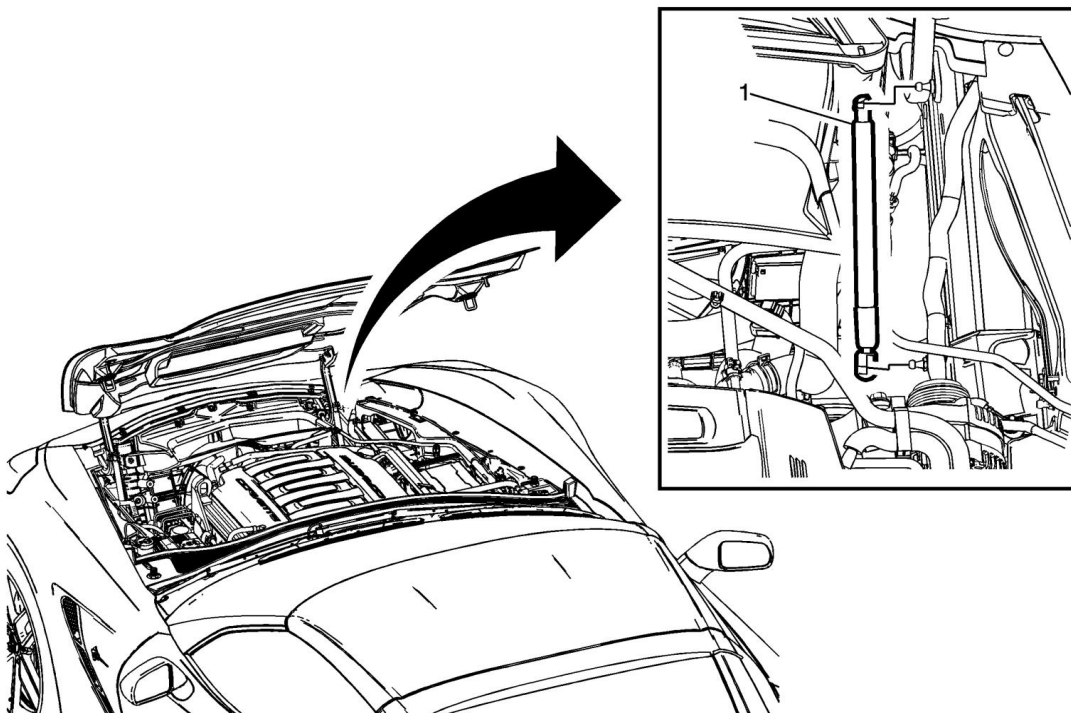

Warning: When a hood hold open device is being removed or installed, provide alternate support to avoid the possibility of damage to the vehicle or personal injury.

© 2019 General Motors. All rights reserved.

Caution: Apply pressure only at the end of the liftgate/hood assist rod that you are removing or attaching. Do NOT apply pressure to the middle of the rod because damage or bending will result.

16. Reconnect Hood Strut (1): Position the strut rod to the ball stud engaging the retaining tabs.

17. Reinstall Air Cleaner Duct:

Note: Refer to images below for vehicle application.

17.1. Install the rubber couplers (1) of air cleaner duct (2) onto throttle body (5) and air cleaner outlet (4).

Note: Ensure the outlet duct is full seated to the mating surfaces before clamping. Verify that the cuff is not rolled under.

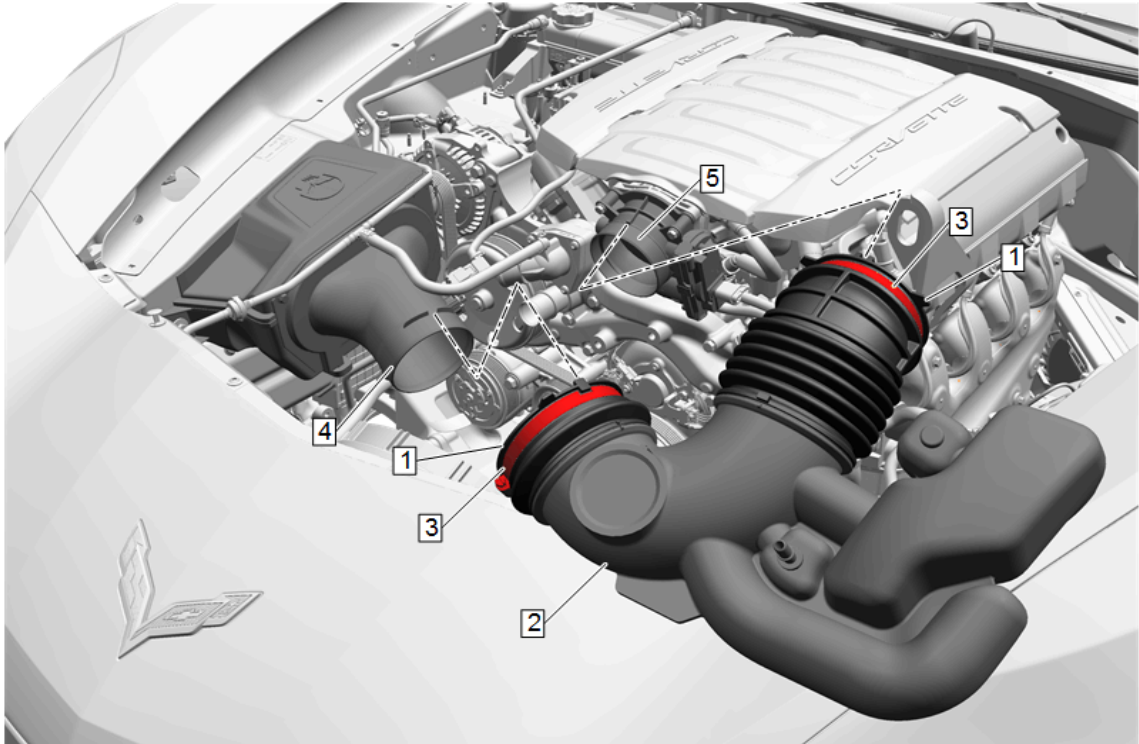

17.2. Stingray and Grand Sport:

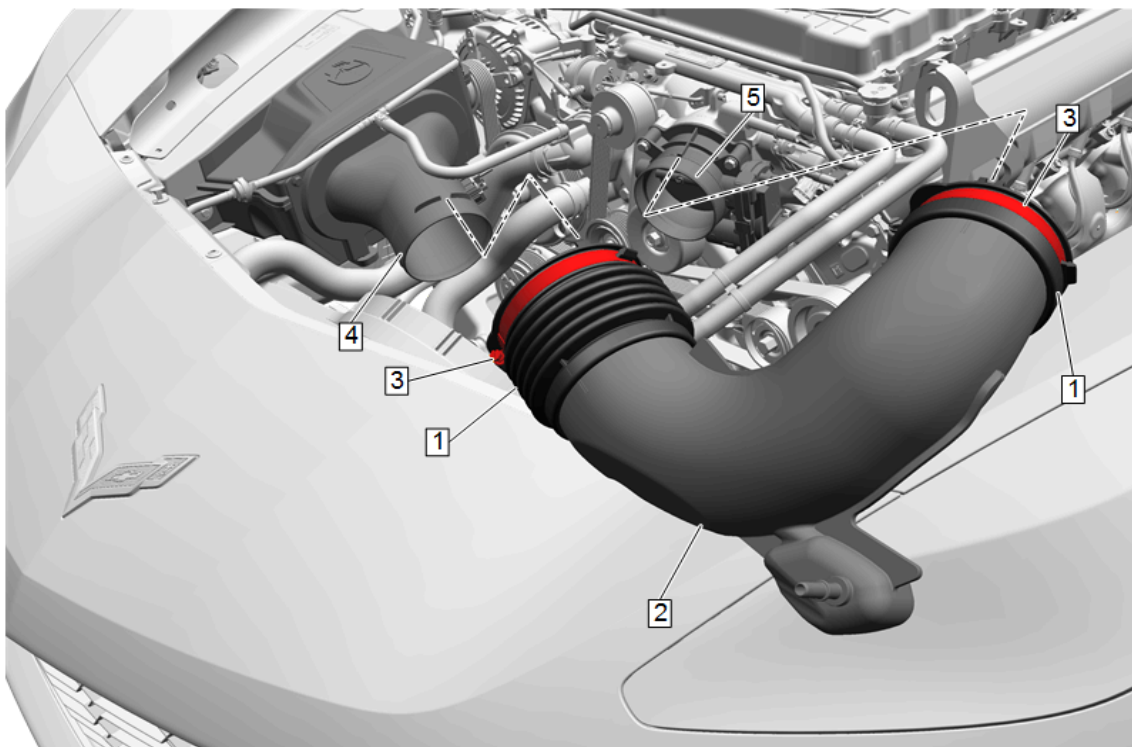

17.3. Z06:

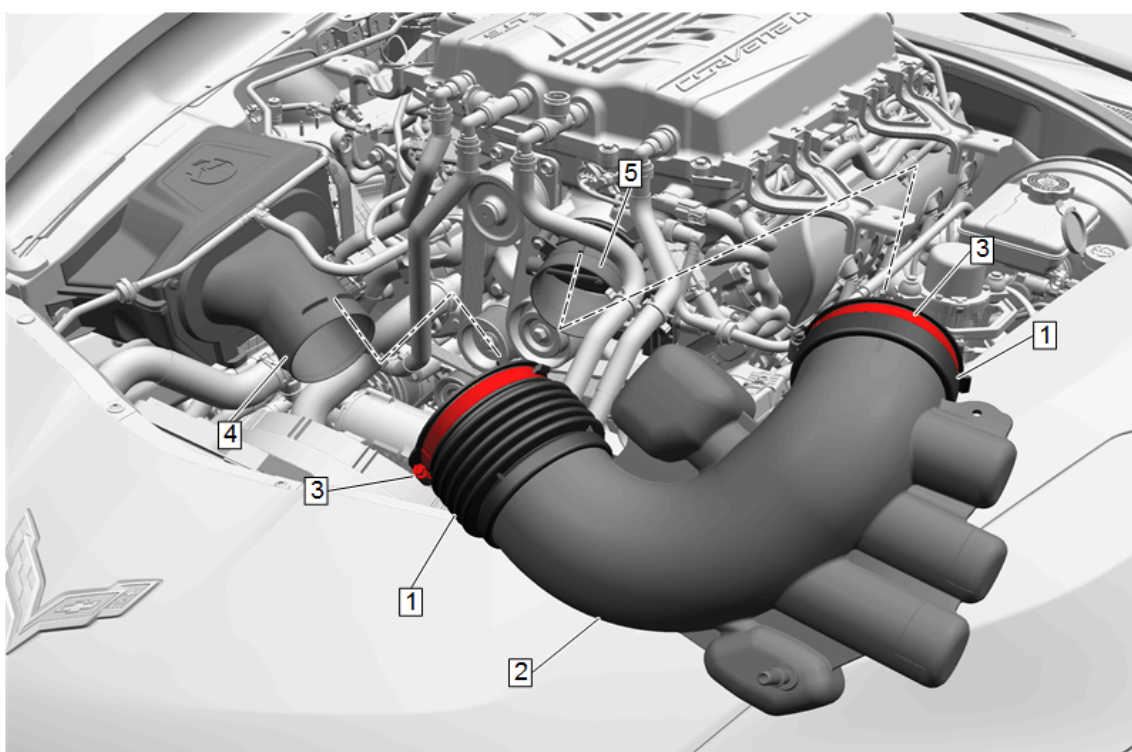

17.4. ZR1:

17.5. Tighten the clamps (3) to 3.5 N.m (31 lb in).

18. Reconnect PCV Connection:

© 2019 General Motors. All rights reserved.

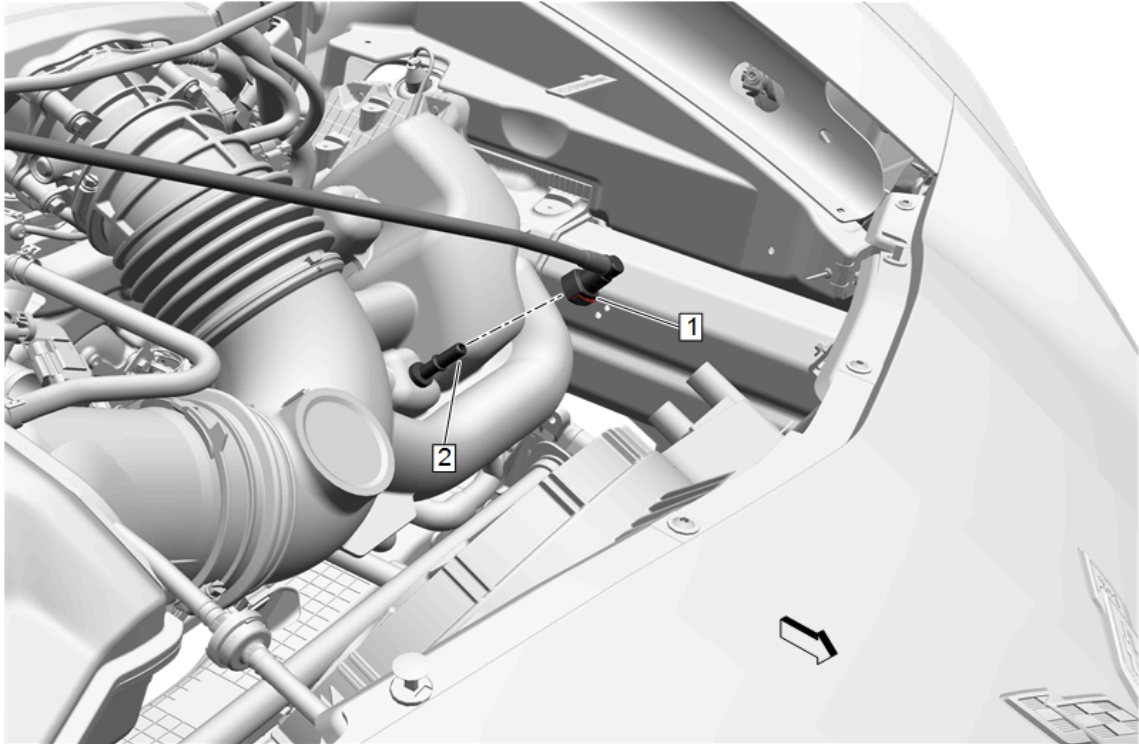

18.1. Stingray and Grand Sport: Connect PCV fitting (1) to air cleaner outlet duct (2), push on until fitting clicks.

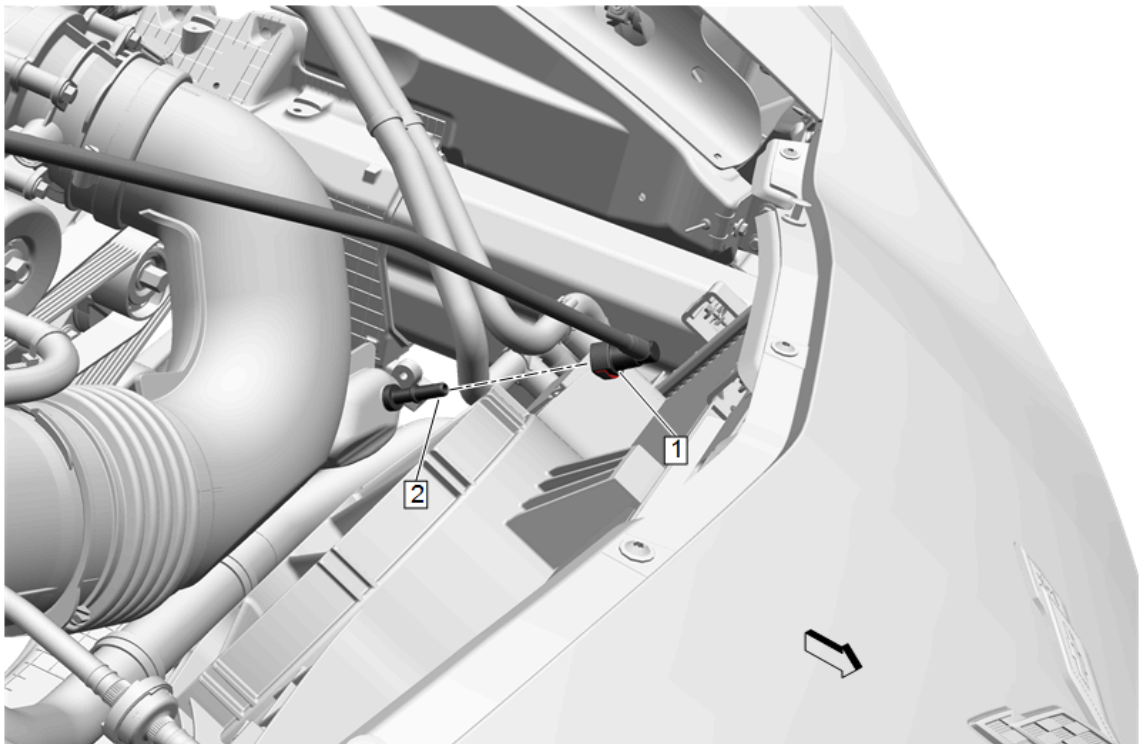

18.2. Z06: Connect PCV fitting (1) to air cleaner outlet duct (2) , push on until fitting clicks.

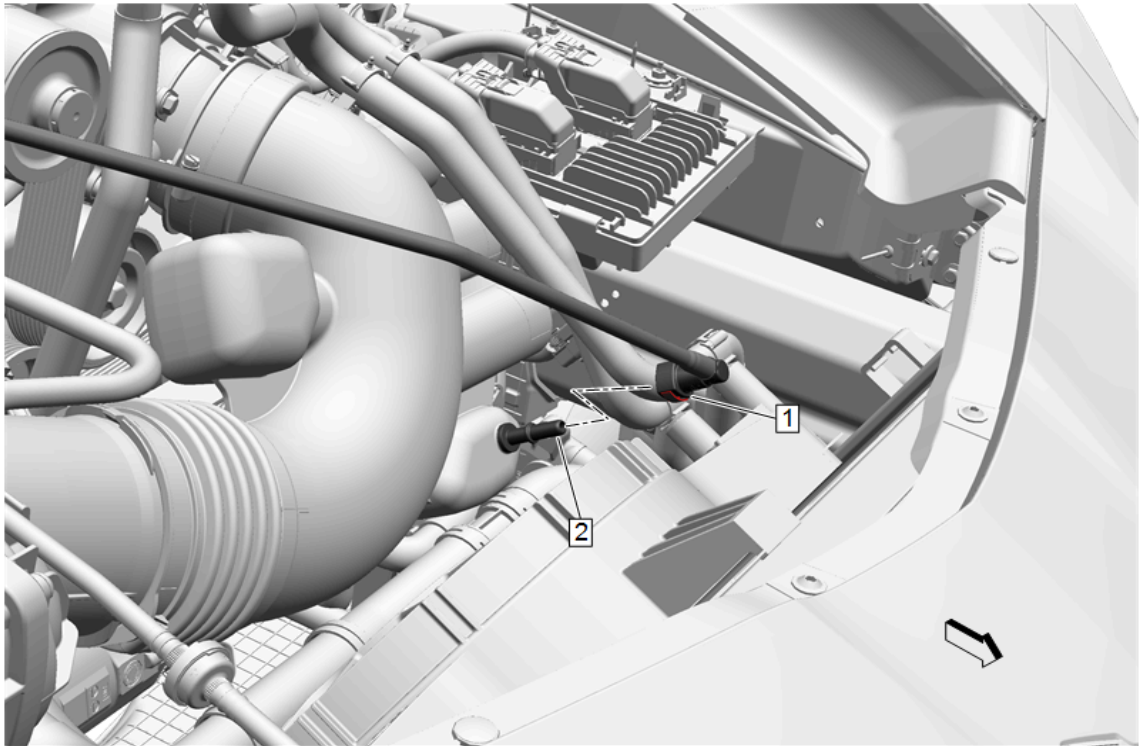

18.3. ZR1: Connect PCV fitting (1) to air cleaner outlet duct (2) , push on until fitting clicks.

19. Install Anti-Abrasion Sleeve:

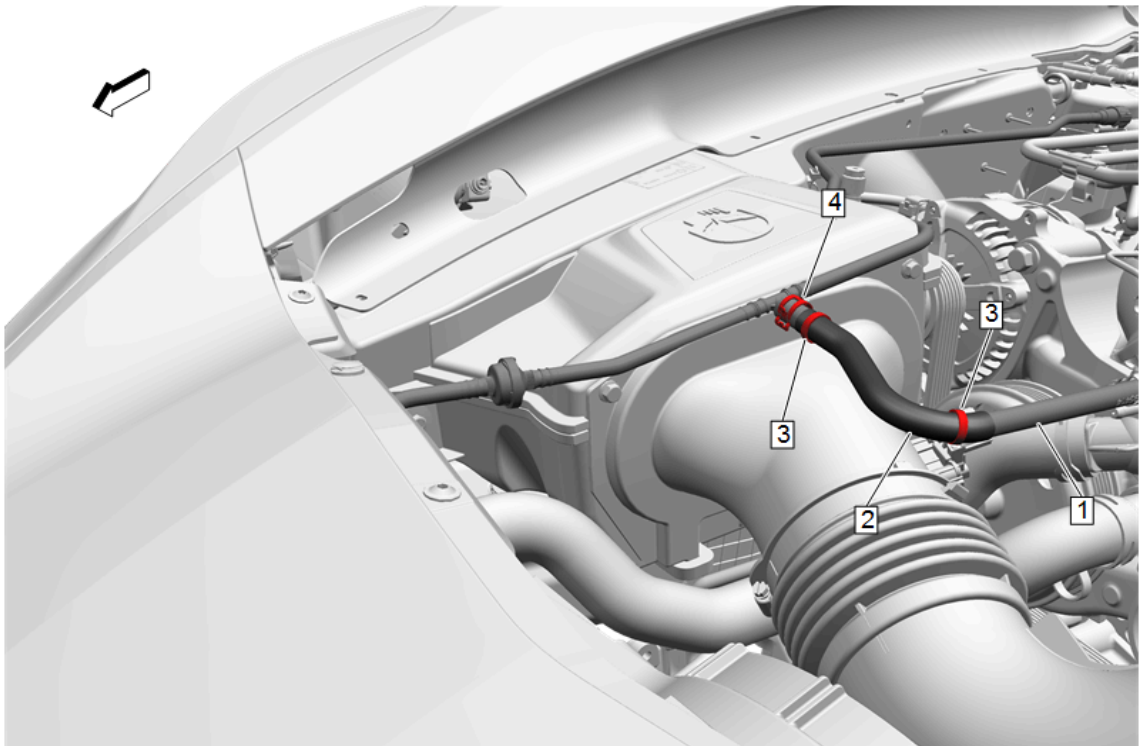

19.1. Wrap anti-abrasion sleeve (2) around the coolant surge line (1) over the air cleaner outlet duct.

© 2019 General Motors. All rights reserved.

19.2. Install the tie straps (3) at the ends of the sleeve, do not over tighten the tie straps.

19.3. Rotate the coolant hose clamp (4) 90° forward and check clearance to air extractor on hood. Adjust clocking as needed.

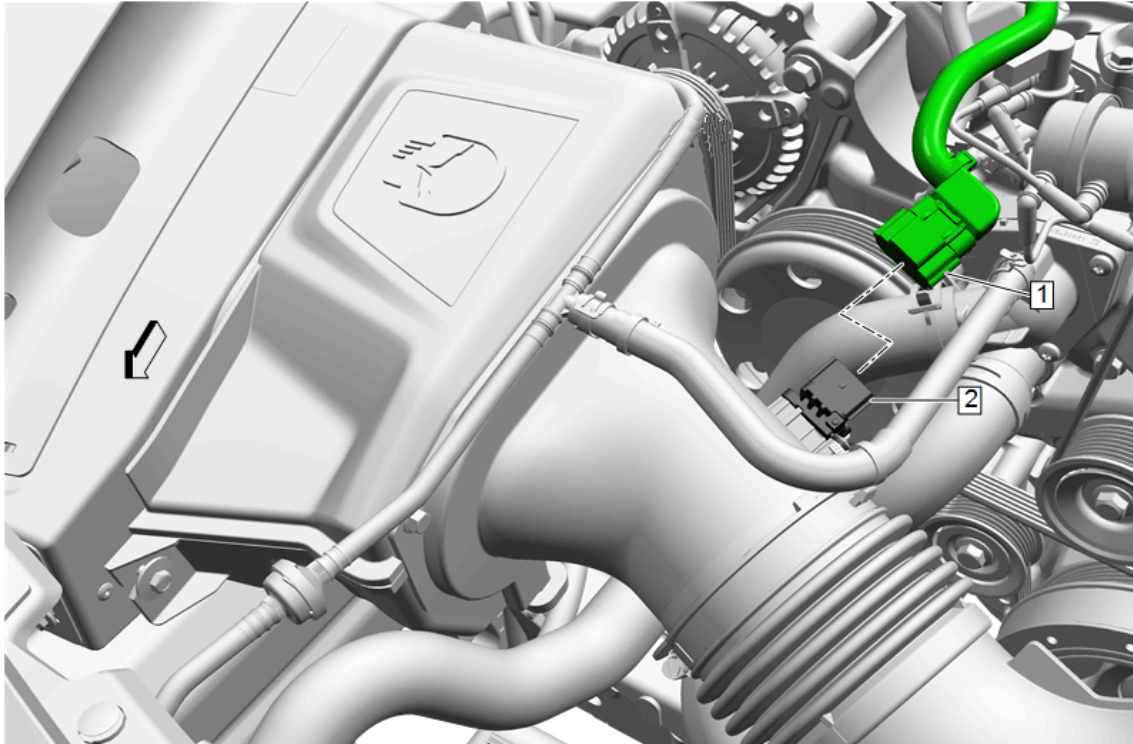

20. Reconnect Mass Air Flow Sensor: Connect the MAFS connector (1) to the MAFS (2) and push the positive retaining tab.

21. Reinstall Radiator Air Upper Baffle Extension:

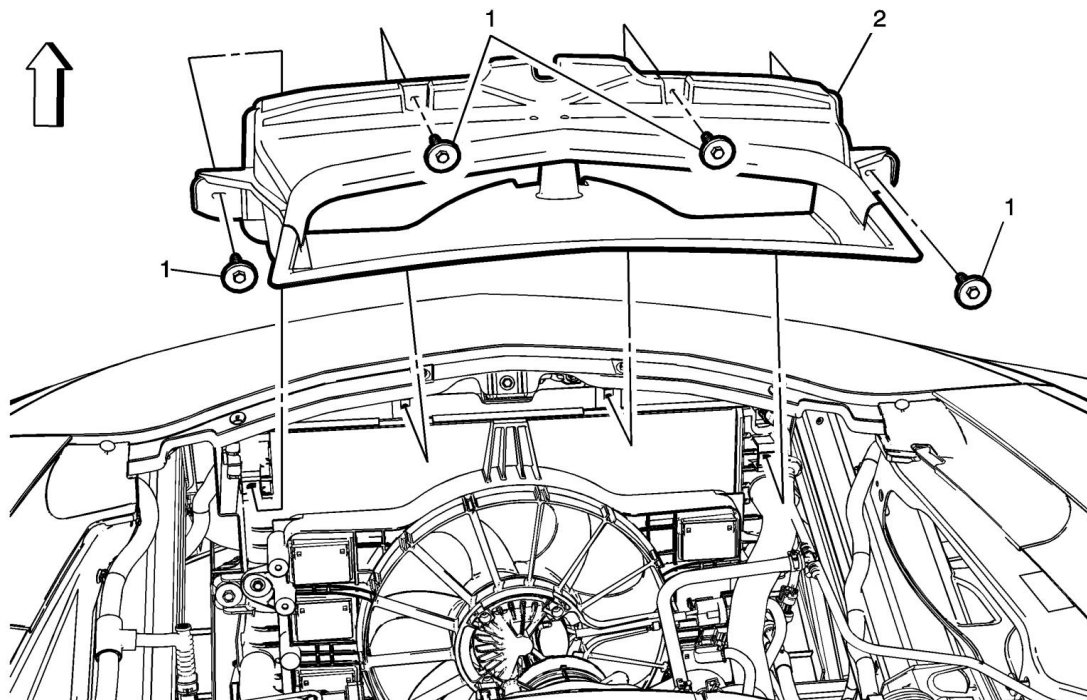

21.1. Stingray, Grand Sport and Z06: Position the radiator air upper baffle extension (2) to vehicle.

© 2019 General Motors. All rights reserved.

21.2. Install the radiator air upper baffle extension bolts (1). Tighten bolts to 2.5 N.m (22 lb in).

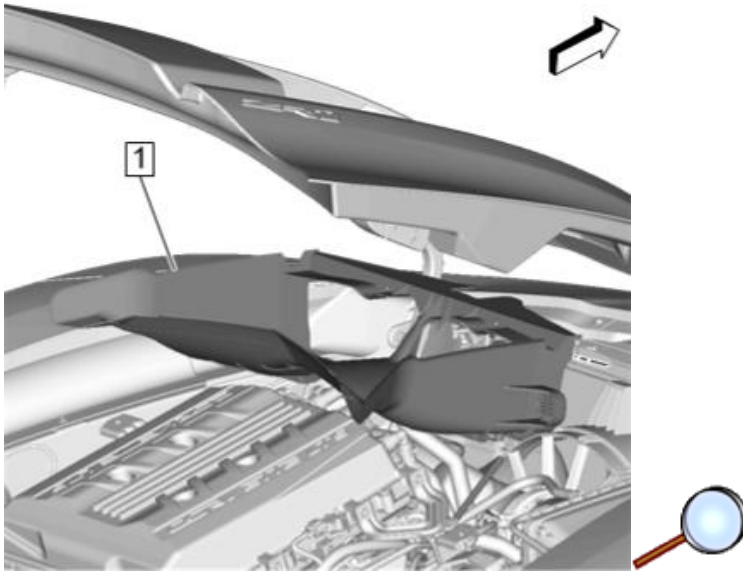

21.3. ZR1: Position the radiator air upper baffle extension (1) to vehicle.

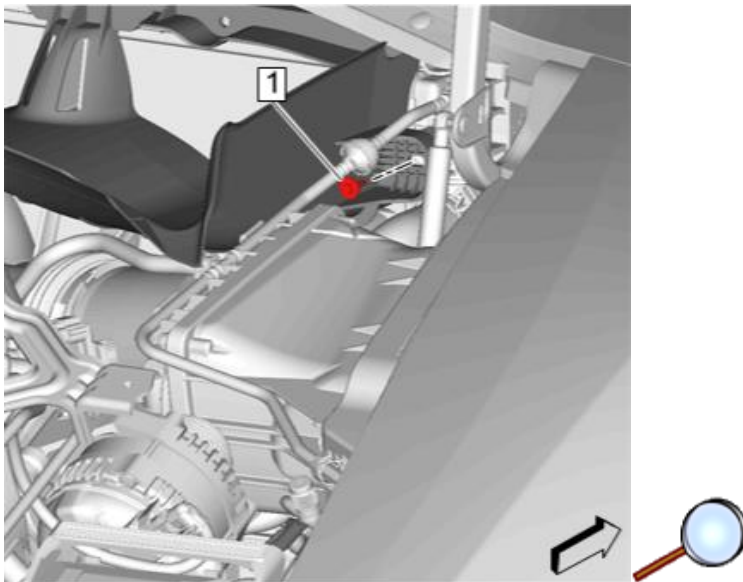

21.4. Install the radiator air upper baffle extension bolt (1). Tighten bolt to 2.5 N.m (22 lb in).

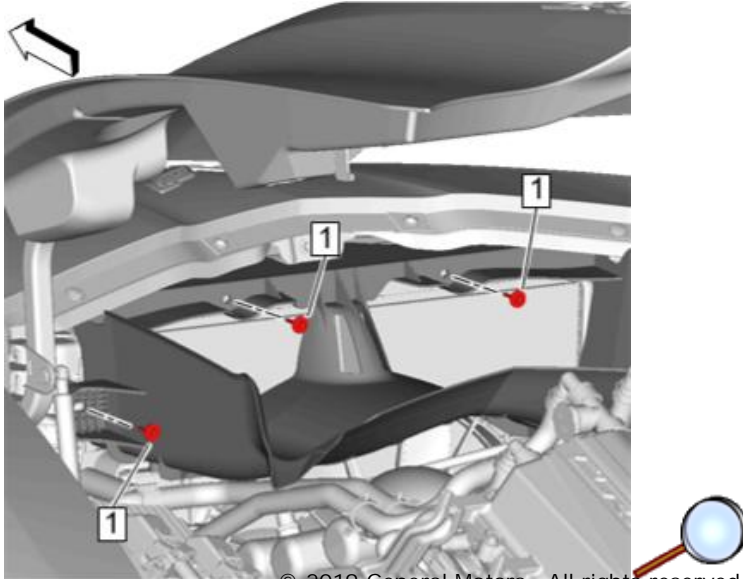

21.5. Install the radiator air upper baffle extension bolts (1). Tighten bolts to 2.5 N.m (22 lb in).

21.6. Affix provided EO label under hood in location so it is easily visible.

22. Install Intake Manifold Cover (For ZR1 Only, for other variants continue to step 24):

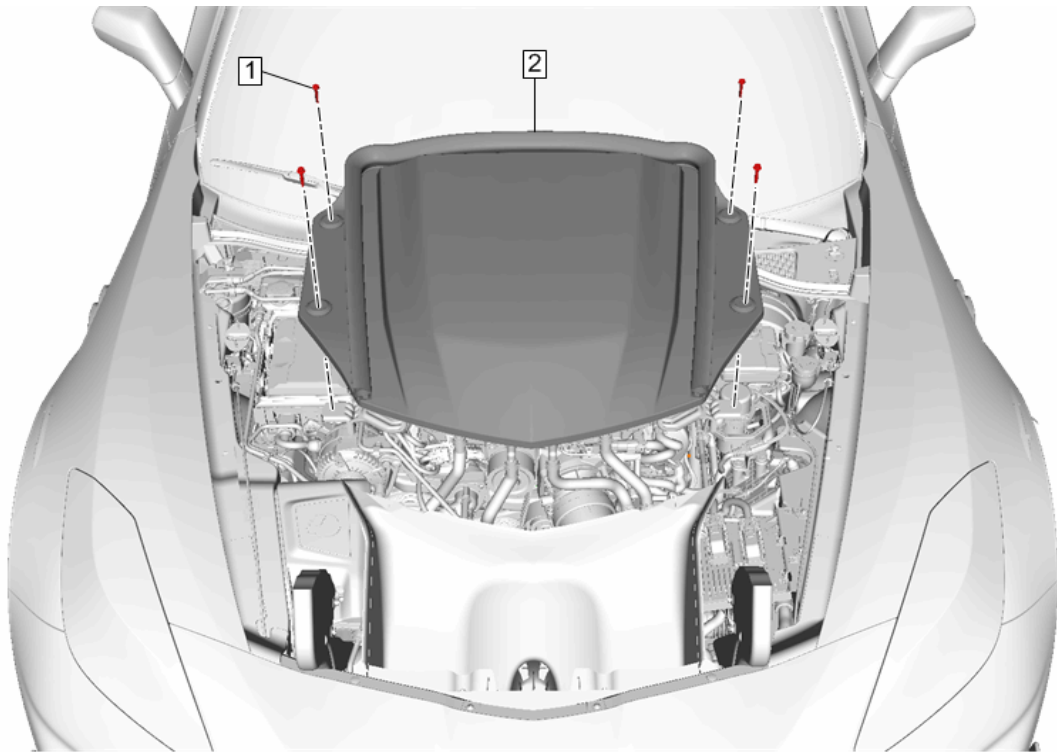

22.1. Carefully position the intake manifold cover (2) to the engine.

22.2. Install the intake manifold cover bolts (1) finger tight (Qty: 4).

22.3. Close the hood.

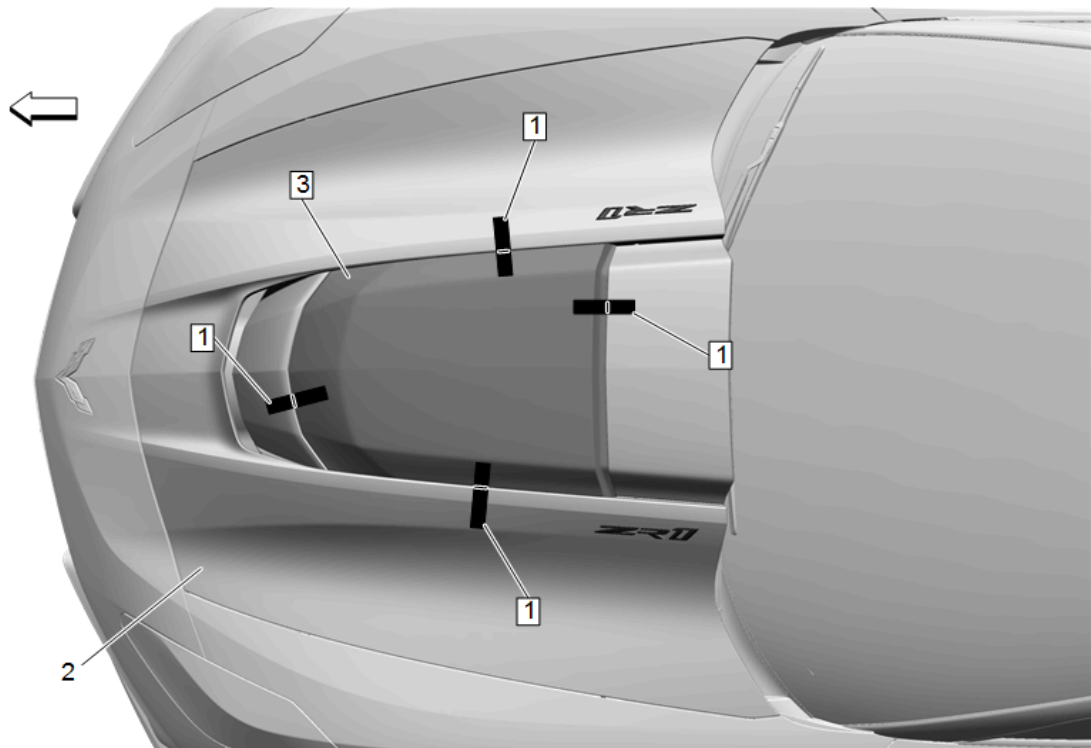

22.4. Realign the masking tape (1) on the intake manifold cover (3) to the masking tape on hood (2).

22.5. Open the hood.

22.6. Torque intake manifold cover bolts to 9 N m (80 lb in) +/- 2Nm (18 lb in). (Torque forward-most fasteners first to prevent shift of engine cover during torquing).

22.7. Re-check alignment:

- Center feature line profile alignment to hood (Req: +/- 1mm).
- Rear Gap from Intake Manifold Cover to Hood (Req: 25.09mm +/- 1mm).
- Top of Intake Manifold Cover flush to hood (Req: -0mm +1mm).

22.8. Remove Tape.

23. Battery Negative Cable Connection:

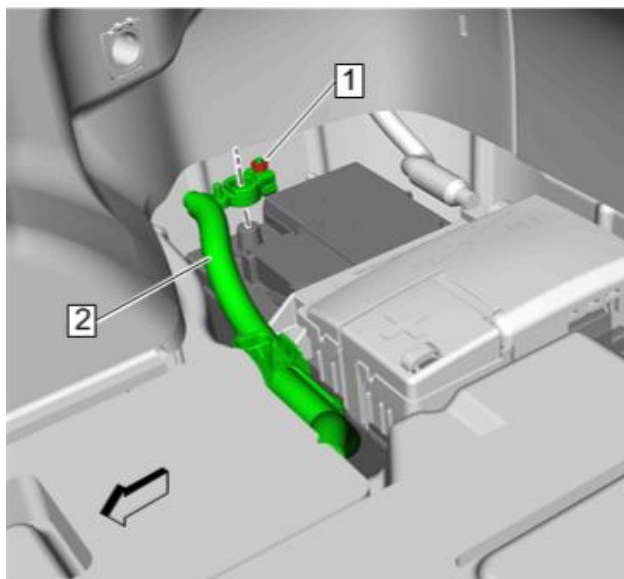

- 23.1. Reinstall the battery negative cable (2) to the battery negative post and tighten the battery negative cable clamp fastener (1) to 5 N.m (44 lb in).

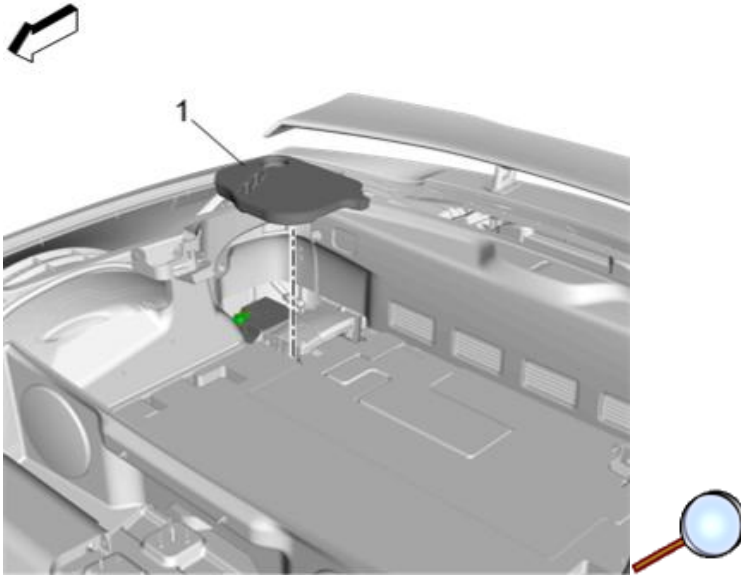

- 23.2. Reinstall the floor panel carpet support (1) to the top of the battery.

24. Reinstall Floor Trim Cover:

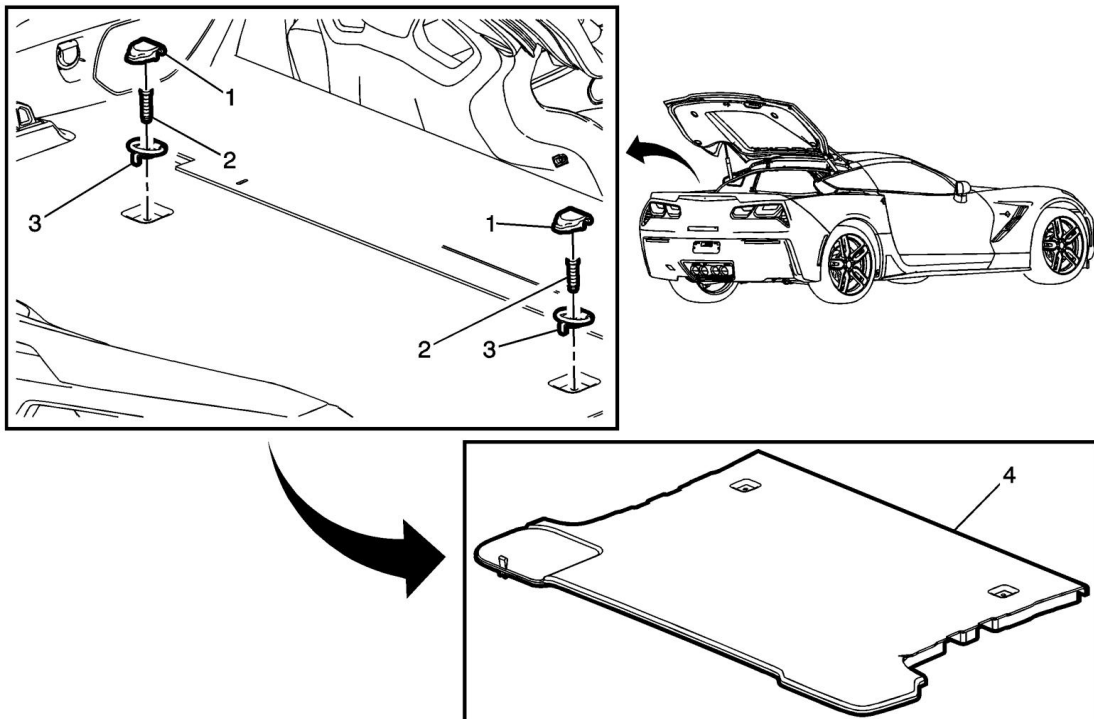

- 24.1. Install rear compartment floor panel trim (4).
 24.2. Install cargo tie down loop assembly (3).
 24.3. Install cargo tie down loop fastener (2). Tighten fastener to 12 N.m (106 lb in).
 24.4. Install cargo tie down loop bolt cap (1).

Congratulations! You have completed the installation of your new Chevrolet Performance Air Intake. Please follow the service intervals outlined below for your new performance air filter (dealers please notify customer): Use only Chevrolet Performance Replacement Air Filters.

Service Interval Max	Inspection Interval Miles	Inspection/Replace Interval Time (Months)
15,000	5,000	12/24