

Rear End Spoiler Package Installation (Instruction Part Number 2097039)

[Installation Instructions Part Number](#)

2097039

Kit Contents

Qty	Description
1	Spoiler
1	Harness
1	Small Parts Kit
2	Short Barrel Nut
2	Long Barrel Nut
4	Large Steel Washer
4	Large Rubber Washer
4	Small Rubber Washer
4	Star Lock Washer
4	Nut Cap
2	Gas Struts
1	Installation Instructions

[Tools Required](#)

- 5/8", 3/4" Hole Saws
- 5/16", 1/8" Drill Bits
- 10mm, 14mm, 16mm Sockets
- Center Punch
- Hammer
- Tape Measure
- Socket
- Ratchet
- Deburring Tool

© 2014 General Motors. All rights reserved.

- GM Super Lube®
- Electrical Tape
- Small Flat-Bladed Screwdriver

Procedure

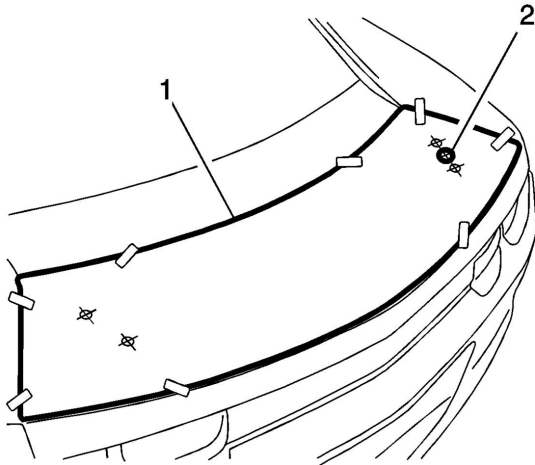

Note: If a stripe kit is to be installed to the vehicle, it should be installed prior to the decklid spoiler.

1. Remove the spoiler and contents from the carton.
2. Inspect all contents to verify all items are present.
3. Align the drill template (1) to the decklid as specified on the drilling template. Carefully position the spoiler on the decklid to confirm hole positions then remove the spoiler.
4. Center punch the five hole locations.
5. Remove the template.
6. Drill 1/8" pilot holes through the outer panel and the inner panel of the decklid at the four spoiler mounting points.

Note: Drill a 1/8" pilot hole (2) through the top decklid panel only for the spoiler wiring harness.

Note: Do not drill through the decklid inner panel.

7. Use a 5/16" drill bit to drill out (top decklid panel only) the four spoiler mounting hole locations.

Note: Do not drill through the decklid inner panel.

8. Use a 5/8" diameter hole saw to drill out (top decklid panel only) the wiring harness pilot hole.

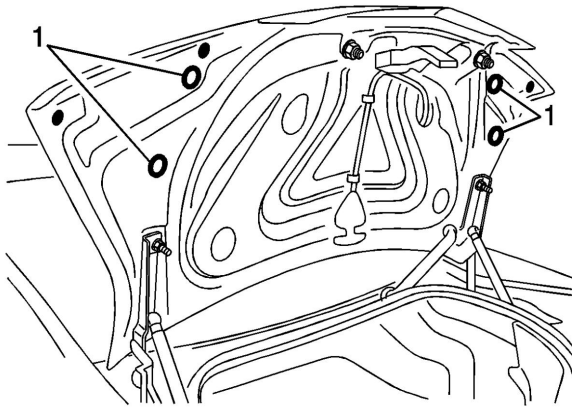

9. Raise the decklid and remove the decklid carpet trim.
10. Place a drop sheet across the trunk opening to catch the metal shavings and to protect the vehicle paint when drilling.
11. Locate the four spoiler mounting pilot holes (1) in the inner decklid panel only and open to 3/4" using a hole saw. If the knockout from the hole saw falls into the decklid, remove it by using a magnet through the two bottom access holes.
12. Deburr all holes drilled.
13. Vacuum up all metal shavings from the drilling.

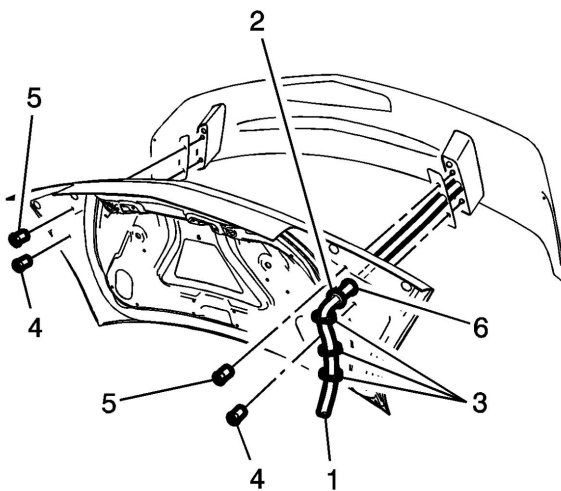

14. Treat all exposed metal with GM Super Lube® and allow to dry.
15. Clean the decklid area where the spoiler adhesive pads will make contact using an alcohol wipe.
- Note: Two people are required for steps 16 to 19.**
16. Tape a guide wire to the spoiler wiring harness (1) and feed the harness through the hole (6) in the decklid. Pull the spoiler harness through and seat the harness grommet (2) in the decklid panel.
17. Remove protective tape from the spoiler adhesive pads and seat the spoiler in position.
18. Apply a firm even pressure to the spoiler to ensure proper adhesion to the decklid.

19. Loosely install the two short barrel nuts (4) and the two long barrel nuts (5) to hold the spoiler to the decklid.
20. Route the spoiler harness down towards the lower right hand corner of the decklid inner panel along the body harness.
21. Use tie straps (3) to attach the spoiler harness to the body harness as required.
22. Remove the RHS trunk side carpet trim.

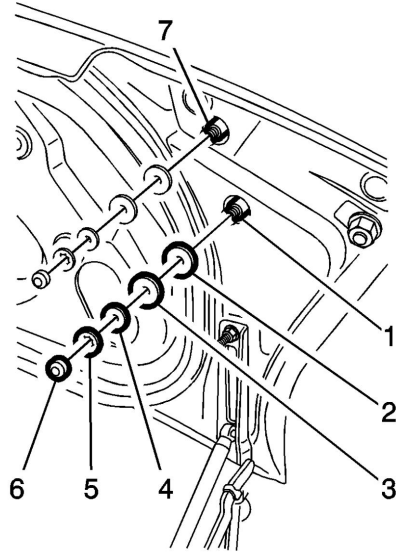

Caution: Use the correct fastener in the correct location. Replacement fasteners must be the correct part number for that application. Fasteners requiring replacement or fasteners requiring the use of thread locking compound or sealant are identified in the service procedure. Do not use paints, lubricants, or corrosion inhibitors on fasteners or fastener joint surfaces unless specified. These coatings affect fastener torque and joint clamping force and may damage the fastener. Use the correct tightening sequence and specifications when installing fasteners in order to avoid damage to parts and systems.

23. Check the alignment of the spoiler on the decklid and tighten the barrel nuts (1), (7) using a flat-bladed screwdriver.
Tighten
Tighten the barrel nuts to 5 Y (3.68 lb ft).
24. Fit large rubber washer (2), large steel washer (3), small rubber washer (4) in the order shown.
25. Press fit star lock washer (5) to the end of the barrel nut and tap on using a 14mm socket. Ensure the star lock washer is seated tightly against the washer.
26. Fit the four nut caps (6) to the barrel nut assemblies using a 16mm socket and hammer to tap on.

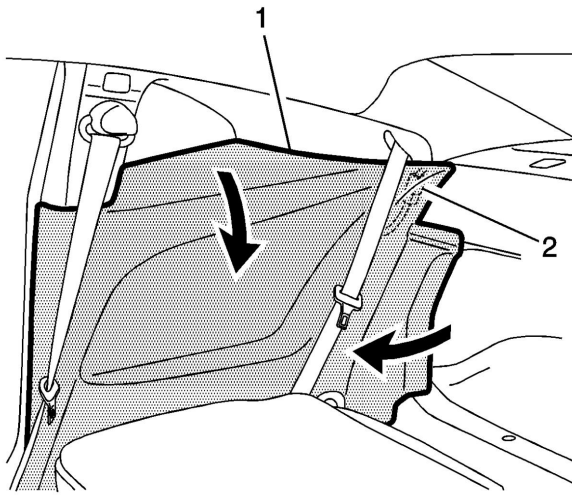

27. From inside the vehicle fold down the back seat.
28. Starting from the rear, unclip the RHS side trim panel (1) to gain access to the parcel shelf body harness connector.
29. Disconnect the connector (2) and connect the spoiler harness breakout harness between the parcel shelf body harness body connectors.

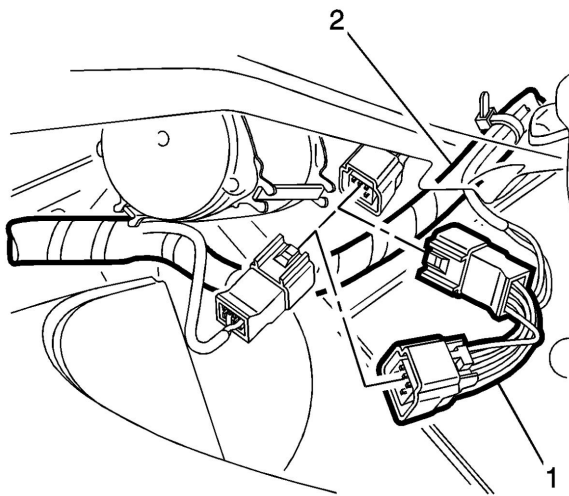

30. Run the breakout harness (1) into the trunk following the vehicle body harness (2), cable tie the harnesses to each other.
31. Connect the breakout harness to the decklid spoiler harness previously routed and tie strap as required.
32. Refit all parts removed in reverse order.

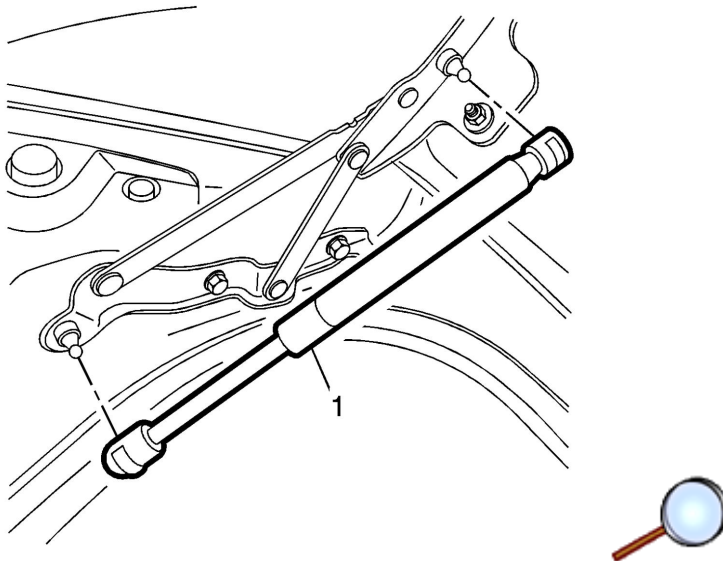

33. Open the decklid and one at a time unclip the gas strut (1) and replace with the replacement strut supplied, repeat on the other side of the decklid. Properly dispose of the replaced gas struts.