

## Pickup and Full Size SUV

# Exhaust Tail Pipe Extension Kit Installation (Dual Tip)

## Installation Instructions Part Number

84699727

Thank you for choosing to upgrade your vehicle with Chevrolet, GMC, or Cadillac Accessories. Chevrolet, GMC, and Cadillac are committed to providing proven, innovative technology. Chevrolet, GMC, and Cadillac Accessory exhaust tips are engineered, developed and tested to exceed your expectations for fit and function. Please visit our websites at <https://accessories.chevrolet.com>, <https://accessories.gmc.com> or <https://accessories.cadillac.com>.

This publication provides general information on components and procedures that may be useful when installing an exhaust tip. Please read the entire publication before starting work. Observe all safety precautions and warnings in the service manuals when installing the exhaust tip on your vehicle. Wear eye protection and appropriate protective clothing. When working under or around the vehicle support it securely with jack stands. Use only the proper tools. Exercise extreme caution when working with flammable, corrosive and hazardous liquids and materials. Some procedures require special equipment or skills. If you do not have the appropriate training, expertise and tools to perform any part of the installation safely, this work should be done by a professional.

Please read this entire publication before starting work. Also, please verify that all of the components listed in the Package Contents section below were shipped in the kit. It is not the intent of these specifications to replace the comprehensive and detailed service practices explained in the GM service manuals. For detailed installation instructions please look to the service manual for your specific vehicle.

GM service manuals are available from: Helm Incorporated PO Box 07130 Detroit, MI 48207

For information about warranty coverage, please contact your local dealer.

The information contained in this publication is presented without any warranty. All the risk for its use is entirely assumed by the user. Specific component design, mechanical procedures and the qualifications of the individual readers are beyond the control of the publisher, and therefore the publisher disclaims all liability incurred in connection with the use of the information provided in this publication.

Chevrolet, Chevy, the Chevrolet Bow Tie Emblem, GMC, Cadillac, General Motors, and GM are all Registered Trademarks of the General Motors Corporation.

### Kit Contents

Qty	Description
1	Polished Exhaust Tip
1	Exhaust Clamp
1	Installation Instructions

### Minimum Required Tool List

3/8" Drive Ratchet

15mm Socket

Torque Wrench

Wire Brush

## Procedure

**Caution:** Never work on a hot exhaust system. Serious injury in the form of burns can result. If the vehicle has been in use and the exhaust system is hot, allow vehicle to cool for at least 1 hour. Always wear eye protection when working under any vehicle.

**Caution:** Approved safety glasses and gloves should be worn when performing this procedure to reduce the chance of personal injury.

**Note:** It is our recommendation that you use a hoist or hydraulic lift to facilitate the installation of your new GM Performance Parts Exhaust Tip package.

Taking all under car safety precautions, lift the vehicle using a hoist or hydraulic lift. Once this has been done, you may begin working on the exhaust system.

### Traditional Clamp

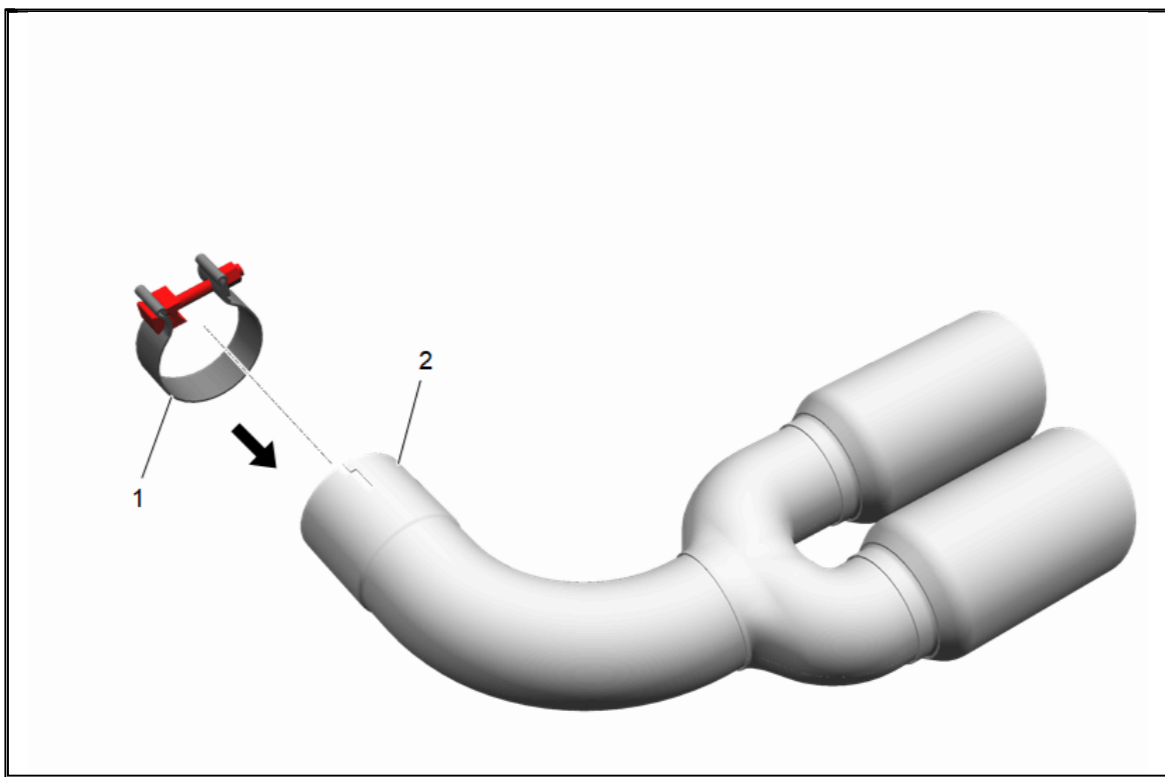

1. Place a clamp (1) over the expanded end of tip (2) as shown.

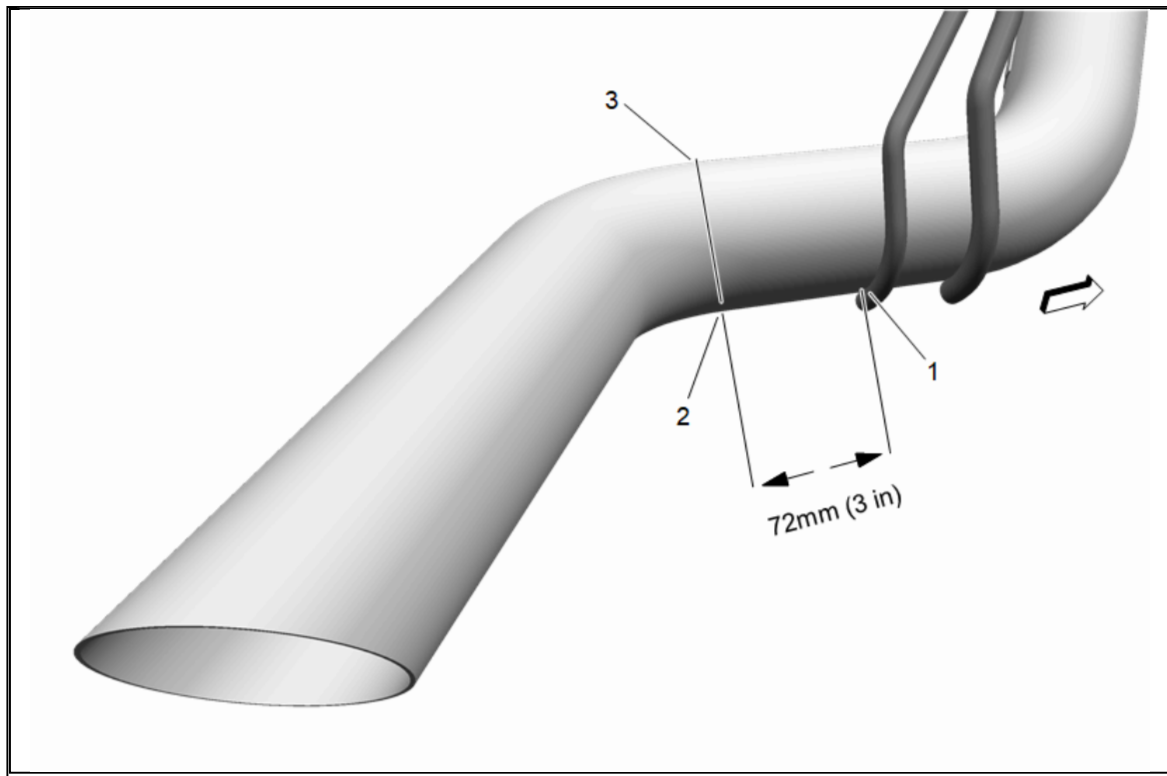

2. On stock exhaust pipe, measure from the rear most exhaust hanger (1) and mark at the 72mm (3 in) dimension (2) from the hanger as shown. Cut (3) and remove rearward pipe section.

**Note:** If your stock exhaust pipe has a resonator patch mounted between the rear hanger and cut section, sanding of protruding welds from the patch may be necessary for proper fitment.

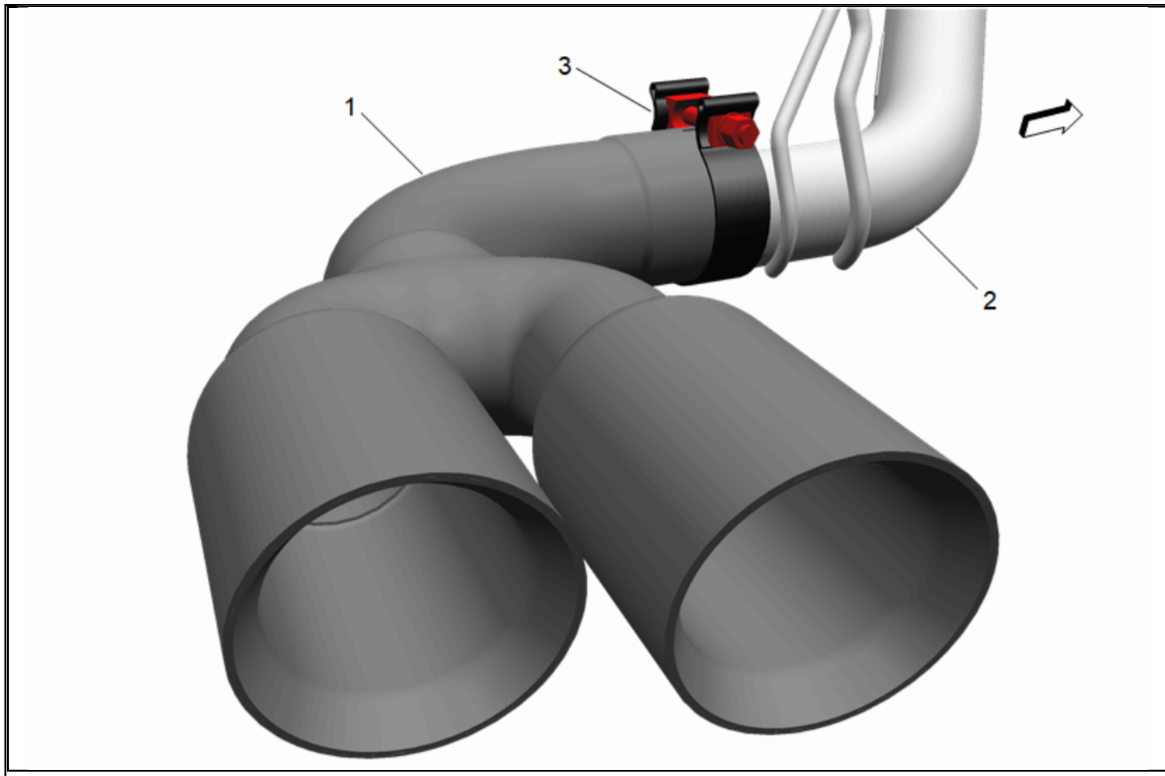

**Note:** Correct flushness of the new exhaust tip is important to prevent burns and scrapes.

- Using a wire brush, remove any surface dirt or corrosion from the stock exhaust pipe, if necessary. Insert the exhaust tip (1) onto the stock exhaust pipe (2). Push the tip on until it is fully inserted into expanded section. Exhaust tips should be positioned approximately 30mm (1 in) away from rear bumper at their nearest point on the passenger side.

**Caution:** Use the correct fastener in the correct location. Replacement fasteners must be the correct part number for that application. Fasteners requiring replacement or fasteners requiring the use of thread locking compound or sealant are identified in the service procedure. Do not use paints, lubricants, or corrosion inhibitors on fasteners or fastener joint surfaces unless specified. These coatings affect fastener torque and joint clamping force and may damage the fastener. Use the correct tightening sequence and specifications when installing fasteners in order to avoid damage to parts and systems.

- Tighten the clamp (3) securing the tip to 50 N.m (37 lb ft).
- Before starting your vehicle, make sure to check all wires, hoses, brake lines, body parts and tires for safe clearance from the exhaust system.
- Congratulations, you have completed the installation of your GM Performance Parts Exhaust Tip.

## Pickup and Full Size SUV

# Exhaust Tail Pipe Extension Kit Installation (Single Tip)

## Installation Instructions Part Number

84699727

Thank you for choosing to upgrade your vehicle with Chevrolet, GMC, or Cadillac Accessories. Chevrolet, GMC, and Cadillac are committed to providing proven, innovative technology. Chevrolet, GMC, and Cadillac Accessory exhaust tips are engineered, developed and tested to exceed your expectations for fit and function. Please visit our websites at <https://accessories.chevrolet.com>, <https://accessories.gmc.com> or <https://accessories.cadillac.com>.

This publication provides general information on components and procedures that may be useful when installing an exhaust tip. Please read the entire publication before starting work. Observe all safety precautions and warnings in the service manuals when installing the exhaust tip on your vehicle. Wear eye protection and appropriate protective clothing. When working under or around the vehicle support it securely with jack stands. Use only the proper tools. Exercise extreme caution when working with flammable, corrosive and hazardous liquids and materials. Some procedures require special equipment or skills. If you do not have the appropriate training, expertise and tools to perform any part of the installation safely, this work should be done by a professional.

Please read this entire publication before starting work. Also, please verify that all of the components listed in the Package Contents section below were shipped in the kit. It is not the intent of these specifications to replace the comprehensive and detailed service practices explained in the GM service manuals. For detailed installation instructions please look to the service manual for your specific vehicle.

GM service manuals are available from: Helm Incorporated PO Box 07130 Detroit, MI 48207

For information about warranty coverage, please contact your local dealer.

The information contained in this publication is presented without any warranty. All the risk for its use is entirely assumed by the user. Specific component design, mechanical procedures and the qualifications of the individual readers are beyond the control of the publisher, and therefore the publisher disclaims all liability incurred in connection with the use of the information provided in this publication.

Chevrolet, Chevy, the Chevrolet Bow Tie Emblem, GMC, Cadillac, General Motors, and GM are all Registered Trademarks of the General Motors Corporation.

### Kit Contents

Qty	Description
1	Polished Exhaust Tip
1	Exhaust Clamp
1	Installation Instructions

### Minimum Required Tool List

3/8" Drive Ratchet

15mm Socket

Torque Wrench

Wire Brush

## Procedure

**Caution:** Never work on a hot exhaust system. Serious injury in the form of burns can result. If the vehicle has been in use and the exhaust system is hot, allow vehicle to cool for at least 1 hour. Always wear eye protection when working under any vehicle.

**Caution:** Approved safety glasses and gloves should be worn when performing this procedure to reduce the chance of personal injury.

**Note:** It is our recommendation that you use a hoist or hydraulic lift to facilitate the installation of your new GM Performance Parts Exhaust Tip package.

Taking all under car safety precautions, lift the vehicle using a hoist or hydraulic lift. Once this has been done, you may begin working on the exhaust system.

### Traditional Clamp

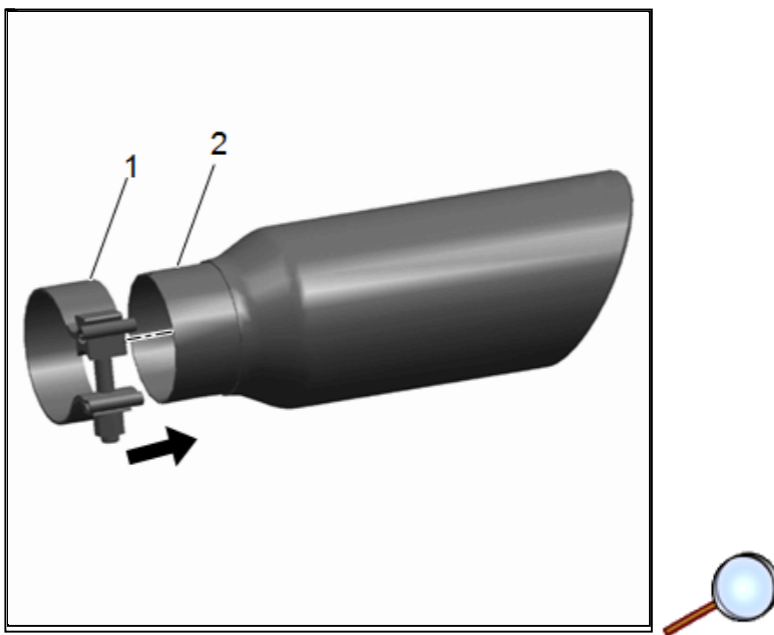

1. Place a clamp (1) over the expanded end of tip (2) as shown. If necessary, use a wire brush to remove any surface dirt or corrosion from the stock exhaust pipe.

**Note:** Correct flushness of the new exhaust tip is important to prevent burns and scrapes.

2. Insert the exhaust tip onto the stock exhaust pipe. Push the tip on until it is approximately 25 mm (1 inch) sub-flush of the bumper or fascia. The stock exhaust pipe should not protrude out of your new exhaust tip.
3. Install the tip over the pipe end. Slide the tip up the pipe until the edge meets the mark. Check your exhaust system for proper clearance under the vehicle and also for tip alignment.

**Caution:** Use the correct fastener in the correct location. Replacement fasteners must be the correct part number for that application. Fasteners requiring replacement or fasteners requiring the use of thread locking compound or sealant are identified in the service procedure. Do not use paints, lubricants, or corrosion inhibitors on fasteners or fastener joint surfaces unless specified. These coatings affect fastener

torque and joint clamping force and may damage the fastener. Use the correct tightening sequence and specifications when installing fasteners in order to avoid damage to parts and systems.

4. Tighten the clamp securing the tip to 43 N.m (32 lb ft).
5. Before starting your vehicle, make sure to check all wires, hoses, brake lines, body parts and tires for safe clearance from the exhaust system.
6. Congratulations, you have completed the installation of your GM Performance Parts Exhaust Tip.

### Worm Clamp

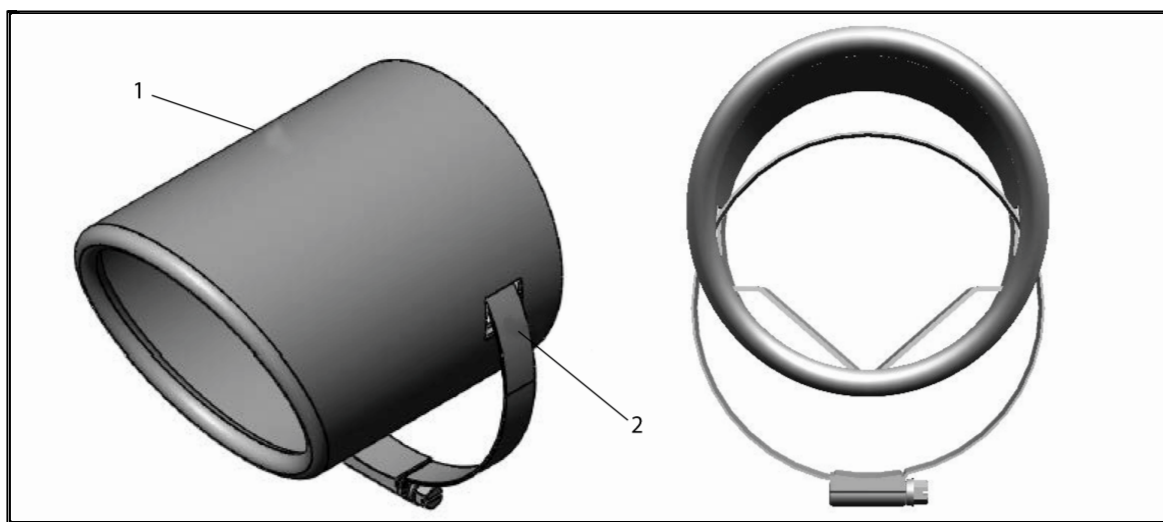

1. Unscrew the worm gear clamp (2) completely so that it may be inserted through both rectangular holes in the exhaust tip (1) as shown.
 

**Note:** Correct flushness of the new exhaust tip is important to prevent burns and scrapes.
2. Insert the exhaust tip onto the stock exhaust pipe. The stock pipe should go in between the triangle bracket and the worm gear clamp. Push the tip on until it is approximately 25 mm (1 inch) sub-flush of the bumper or fascia. The stock exhaust pipe should not protrude out of your new exhaust tip.
3. Install the tip over the pipe end. Slide the tip up the pipe until the edge meets the mark. Check your exhaust system for proper clearance under the vehicle and also for tip alignment.
 

**Caution:** Use the correct fastener in the correct location. Replacement fasteners must be the correct part number for that application. Fasteners requiring replacement or fasteners requiring the use of thread locking compound or sealant are identified in the service procedure. Do not use paints, lubricants, or corrosion inhibitors on fasteners or fastener joint surfaces unless specified. These coatings affect fastener torque and joint clamping force and may damage the fastener. Use the correct tightening sequence and specifications when installing fasteners in order to avoid damage to parts and systems.
4. Tighten the clamp securing the tip to 43 N.m (32 lb ft).
5. Before starting your vehicle, make sure to check all wires, hoses, brake lines, body parts and tires for safe clearance from the exhaust system.
6. Congratulations, you have completed the installation of your GM Performance Parts Exhaust Tip.

## Full Size SUV

**Exhaust Tail Pipe Extension Kit Installation (Single Tip)****Installation Instructions Part Number**

84699727

**Kit Contents**

<b>Qty</b>	<b>Description</b>
1	Polished Exhaust Tip
1	Exhaust Clamp
1	Installation Instructions

Thank you for choosing to upgrade your vehicle with Chevrolet or GMC Accessories. Chevrolet and GMC are committed to providing proven, innovative technology. Chevrolet and GMC Accessory exhaust tips are engineered, developed and tested to exceed your expectations for fit and function.

Please visit our websites at: <https://accessories.chevrolet.com> | <https://accessories.gmc.com>

This publication provides general information on components and procedures that may be useful when installing an exhaust tip. Please read the entire publication before starting work. Observe all safety precautions and warnings in the service manuals when installing the exhaust tip on your vehicle. Wear eye protection and appropriate protective clothing. When working under or around the vehicle support it securely with jack stands. Use only the proper tools. Exercise extreme caution when working with flammable, corrosive and hazardous liquids and materials. Some procedures require special equipment or skills. If you do not have the appropriate training, expertise and tools to perform any part of the installation safely, this work should be done by a professional.

Please read this entire publication before starting work. Also, please verify that all of the components listed in the Package Contents section below were shipped in the kit. The information below is divided into the following sections: Package contents and installation instructions. It is not the intent of these specifications to replace the comprehensive and detailed service practices explained in the GM service manuals. For detailed installation instructions please look to the service manual for you specific vehicle.

For information about warranty coverage, please contact your local dealer.

The information contained in this publication is presented without any warranty. All the risk for its use is entirely assumed by the user. Specific component design, mechanical procedures and the qualifications of the individual readers are beyond the control of the publisher, and therefore the publisher disclaims all liability incurred in connection with the use of the information provided in this publication.

Chevrolet, Chevy, the Chevrolet Bow Tie Emblem, GMC, General Motors, and GM are all Registered Trademarks of the General Motors Corporation.

**Minimum Required Tool List**

3/8" Drive Ratchet

15mm Socket

Torque Wrench



Wire Brush

## Procedure

**Caution:** Never work on a hot exhaust system. Serious injury in the form of burns can result. If the vehicle has been in use and the exhaust system is hot, allow vehicle to cool for at least 1 hour. Always wear eye protection when working under any vehicle.

**Note:** It is our recommendation that you use a hoist or hydraulic lift to facilitate the installation of your new GM Performance Parts Exhaust Tip package.

Taking all under car safety precautions, lift the vehicle using a hoist or hydraulic lift. Once this has been done, you may begin working on the exhaust system.

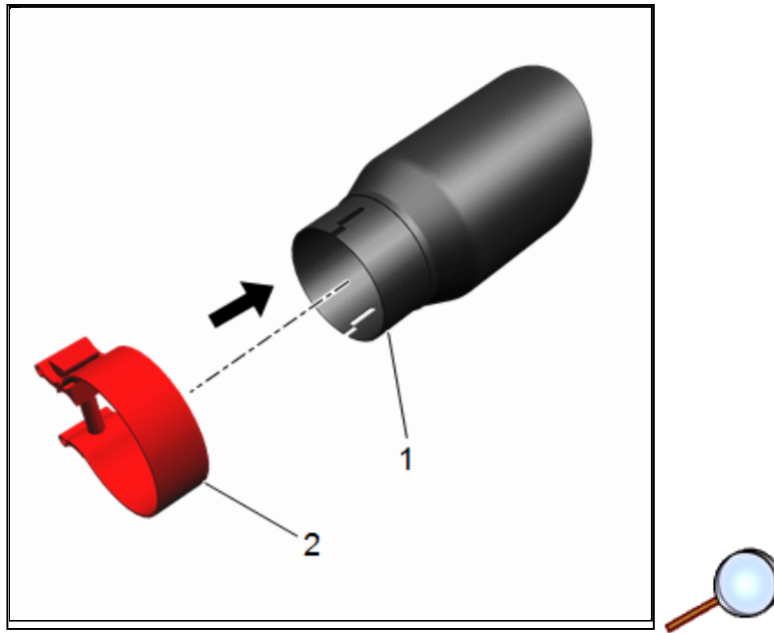

1. Place a clamp (2) over the expanded end of tip (1) as shown.

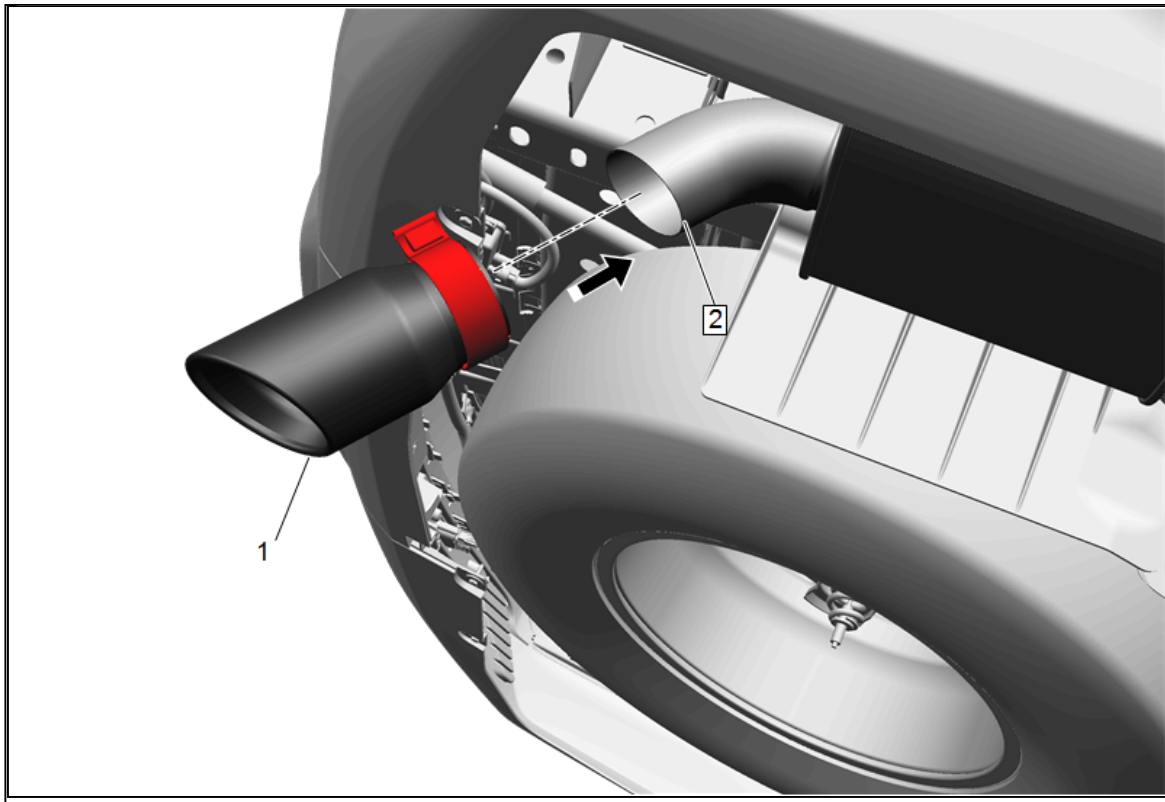

2. Install the tip (1) over the pipe end (2). Slide the tip up the pipe as far as the bend in the exhaust will allow. If you tip has a logo, ensure the logo is facing upward for proper tip alignment.

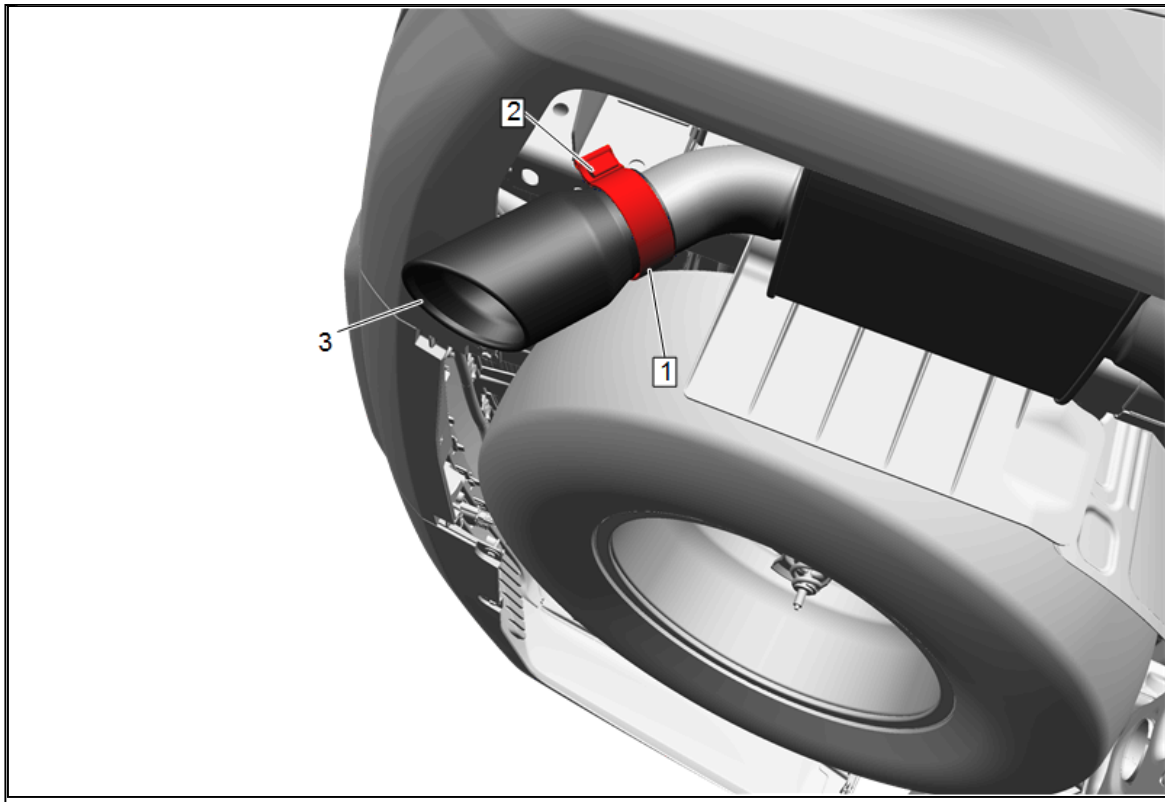

**Caution:** Use the correct fastener in the correct location. Replacement fasteners must be the correct part number for that application. Fasteners requiring replacement or fasteners requiring the use of thread locking compound or sealant are identified in the service procedure. Do not use paints, lubricants, or corrosion inhibitors on fasteners or fastener joint surfaces unless specified. These coatings affect fastener torque and joint clamping force and may damage the fastener. Use the correct tightening sequence and specifications when installing fasteners in order to avoid damage to parts and systems.

3. Rotate the clamp (1) so that the clamp bolt (2) is not visible from the exterior of the vehicle. Tighten the clamp securing the tip to 43 N.m (32 lb ft).
4. Before starting your vehicle, make sure to check all wires, hoses, brake lines, body parts and tires for safe clearance from the exhaust system.
5. Congratulations, you have completed the installation of your GM Performance Parts Exhaust Tip.