

Rear End Spoiler Package Installation (Instruction P/N 22967800)

[Installation Instructions Part Number](#)

22967800

Kit Contents

Qty	Description
1	Spoiler
9	Hex Flange Nut (M6)
1	Drill Template
2	Solvent Pad
1	Installation Instructions

[Tools Required](#)

- Power Drill
- Safety Glasses
- Center Punch
- Hammer
- 1/8" Drill Bit
- 13/32" Drill Bit
- 17/64" Drill Bit
- Deburr Tool
- 10 mm drill stopper (or equivalent)
- Masking Tape
- Torque Wrench
- Ratchet
- Extension
- Socket (10mm)
- Universal Joint

[Vehicle Preparation](#)

1. Temperature must be between 61°F-86°F (16°C-31°C).
2. Wash and thoroughly dry fascia
3. For best results, fascia should be free of damage (dents, scuffs, creases, fractures, etc).

4. Do not use petroleum based cleaning products. If a stronger cleaner is required, we recommend using 3M® general purpose adhesive cleaner (P/N 08984) with a clean cloth to remove all visible contaminants (road tar, etc). It may take the use of several cloths to obtain a clean surface. It is important to replace the cloth when soiled or you will be smearing or wiping contaminants back on the vehicle. After using the adhesive cleaner, use the SOLVENT PKG-BODY SURF CLNR; (P/N 12365938 14W 0849Z 0030).
5. Place drop cloth inside trunk so that it sufficiently covers area under fascia.

Spoiler Installation

Note:

- Paint spoiler as required.
- Prior to finishing or refinishing refer to GM4901M-D-005 Refinish Manual for recommended products. Do not combine paint systems. Refer to paint manufacturers recommendations for further information.

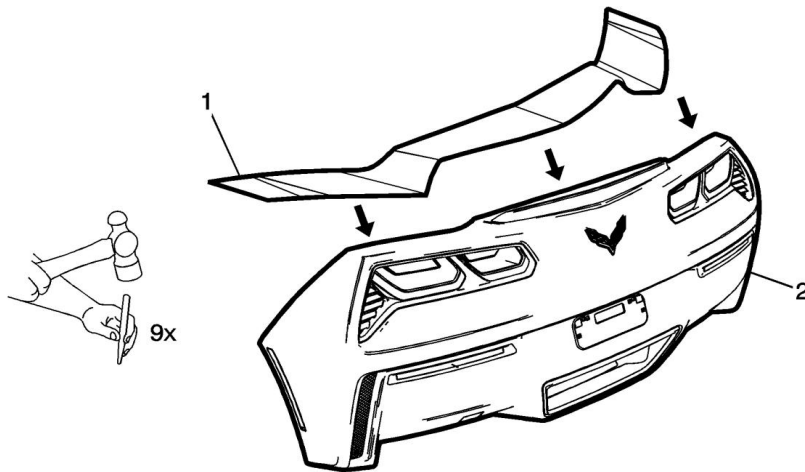

1. Position and secure holes template (1) on fascia upper surface (2).

Caution: Always check scale, size and position of all templates before drilling. Failing to do so may cause damage to the vehicle, misalignment of components or the inability to install the accessory.

2. Center punch the marked holes 9X as located on the template.

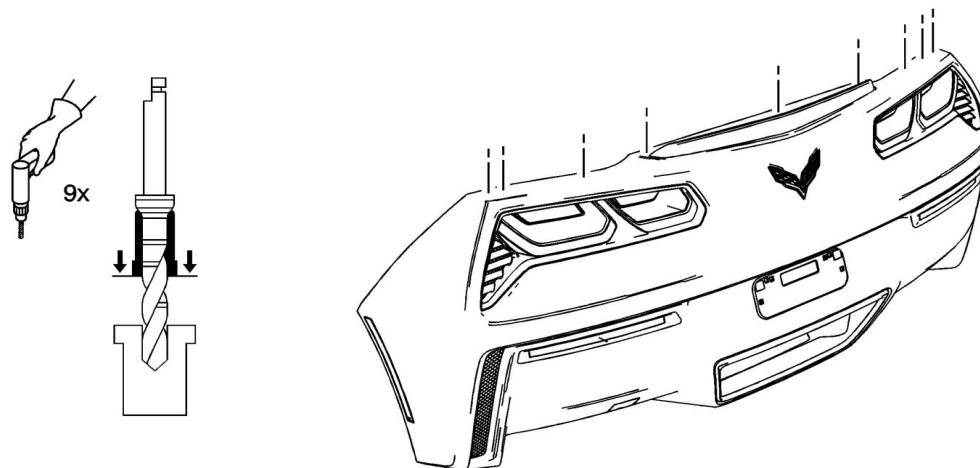

3. Drill 9X 1/8" pilot holes on punched locations.

- Using a 10 mm drill stopper (or equivalent), enlarge the diameter of 9X holes according to template.

Note: DO NOT DRILL MORE THAN 10MM TO AVOID DRILLING INTO THE TAIL LAMPS.

Note: CARE SHOULD BE TAKEN DURING THE DRILLING OF THE INNER FASCIA NOT TO DAMAGE THE OUTER FASCIA.

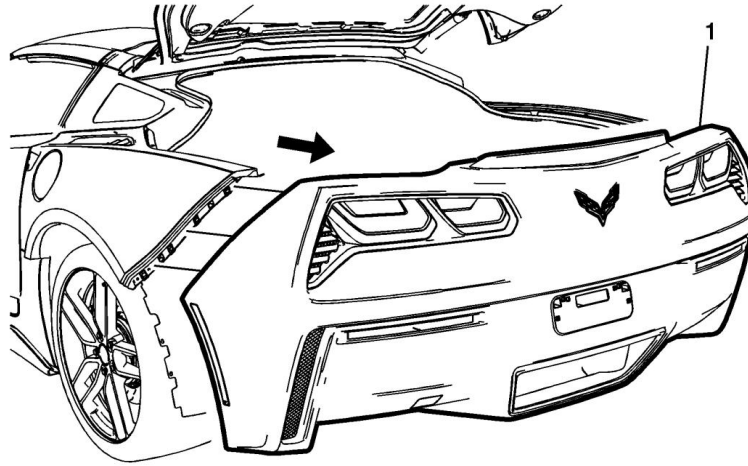

- Remove the rear bumper fascia (1). Refer to Vehicle Service Manual.

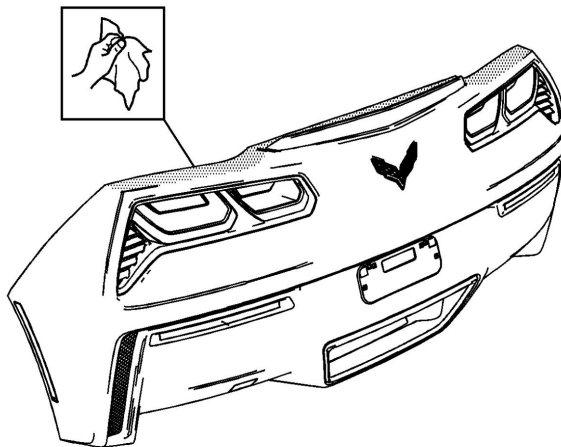

- Clean the fascia upper surface with the provided pads.

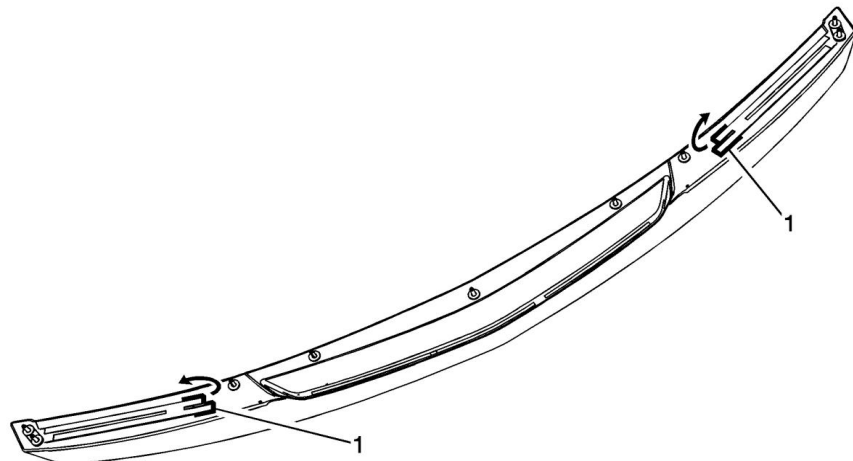

7. Remove the tape liner by using the pull tab (1).

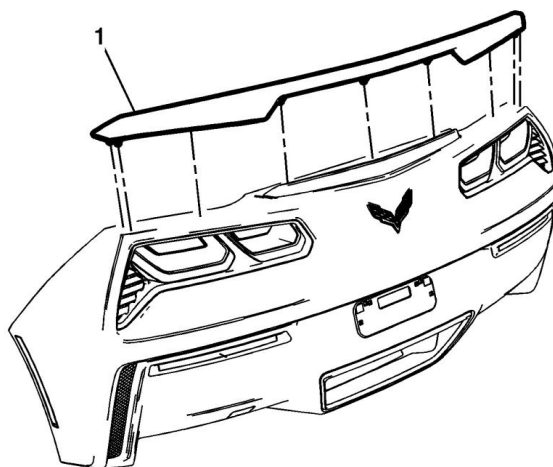

8. Place the spoiler (1) to the top of the fascia.

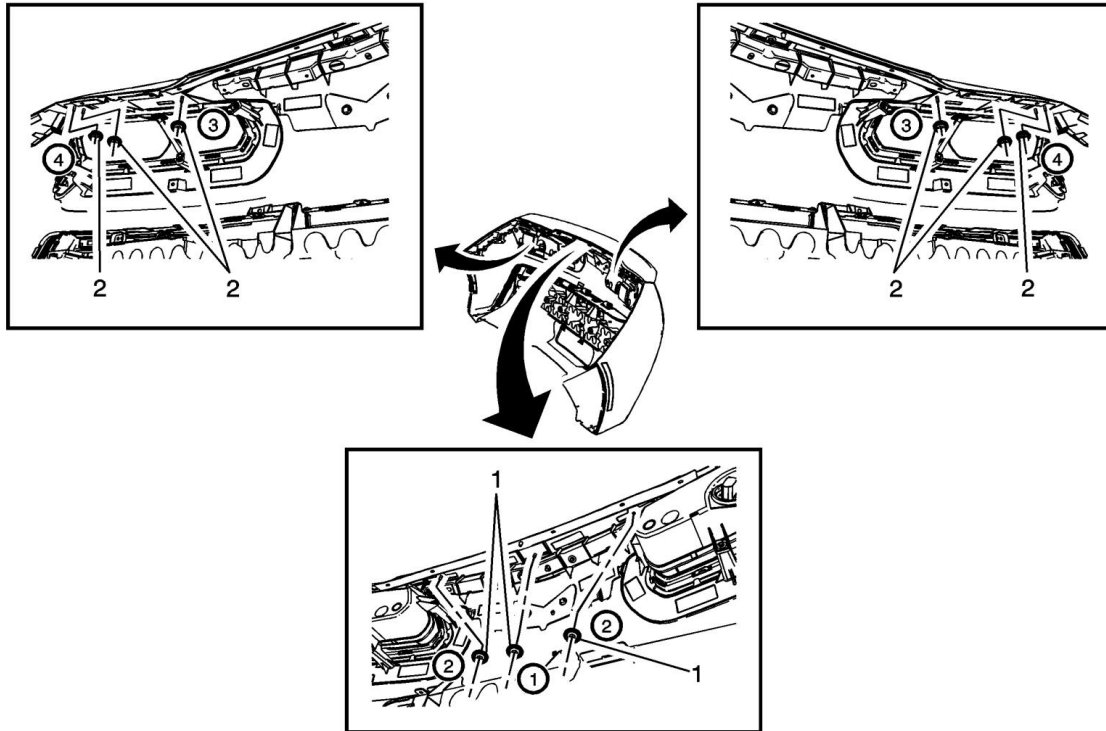

Caution: Use the correct fastener in the correct location. Replacement fasteners must be the correct part number for that application. Fasteners requiring replacement or fasteners requiring the use of thread locking compound or sealant are identified in the service procedure. Do not use paints, lubricants, or corrosion inhibitors on fasteners or fastener joint surfaces unless specified. These coatings affect fastener torque and joint clamping force and may damage the fastener. Use the correct tightening sequence and specifications when installing fasteners in order to avoid damage to parts and systems.

9. Secure spoiler with the center 3 M6 nuts (1). Torque to sequence as indicated.
Tighten
Tighten the M6 nuts to 7 N.m (5.2 lb ft).
10. Secure the spoiler with the outer 6 M6 nuts (2). Torque to the sequence as indicated.
Tighten
Tighten the M6 nuts to 7 N.m (5.2 lb ft).
11. Apply pressure between the spoiler and the fascia to properly wet out the tape.

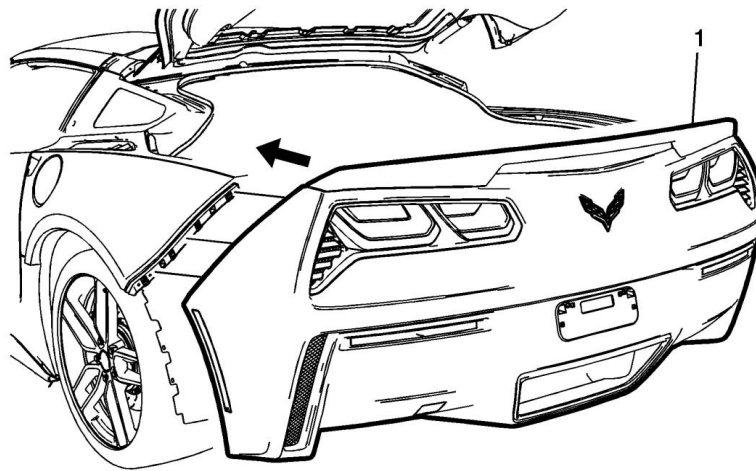

12. Install the rear bumper fascia. Refer to Vehicle Service Manual.

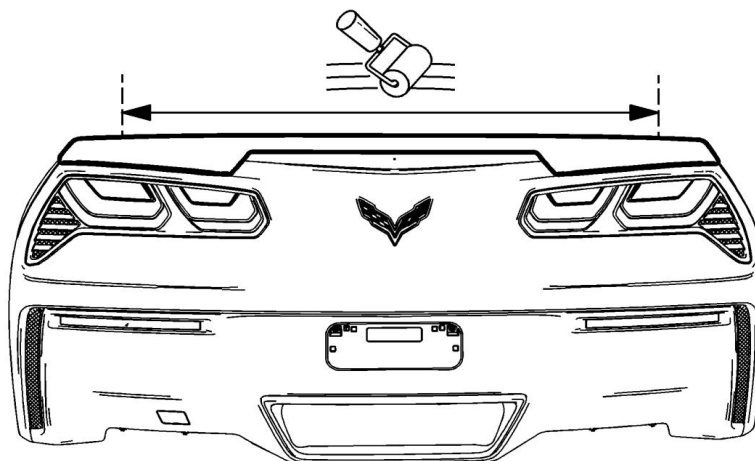

13. With the recommended usage of a rubber roller, apply 15PSI or equal pressure along the entire perimeter of the spoiler to ensure good adhesion.