

## Body Side Molding Kit Installation (Heavy Duty Crew and Extended Cab)

### [Installation Instructions Part Number](#)

22998789

#### Kit Contents

Qty	Description
2	Front Side Door Molding
2	Rear Side Door Molding (Crew, Extended Cab)
1	Installation Instructions

### [Procedure](#)

Apply the body side moldings in an environment free of dust and dirt. Dust and dirt could come in contact with the adhesive surface and prevent proper adhesion.

1. The part surface should be 21°C (70°F) prior to installation. The vehicle should remain 21°C (70°F) for one hour after assembly to allow the adhesive to develop sufficient bond strength.
2. Clean any remaining residue with a 50/50 mixture by volume of isopropyl alcohol and clean drinkable water. Wipe the surface dry with a clean lint free towel.
3. When removing protective liners from the adhesive tape, be careful not to touch the tape with hands and do not allow tape to come in contact with dirty or any foreign matter prior to adhesion.

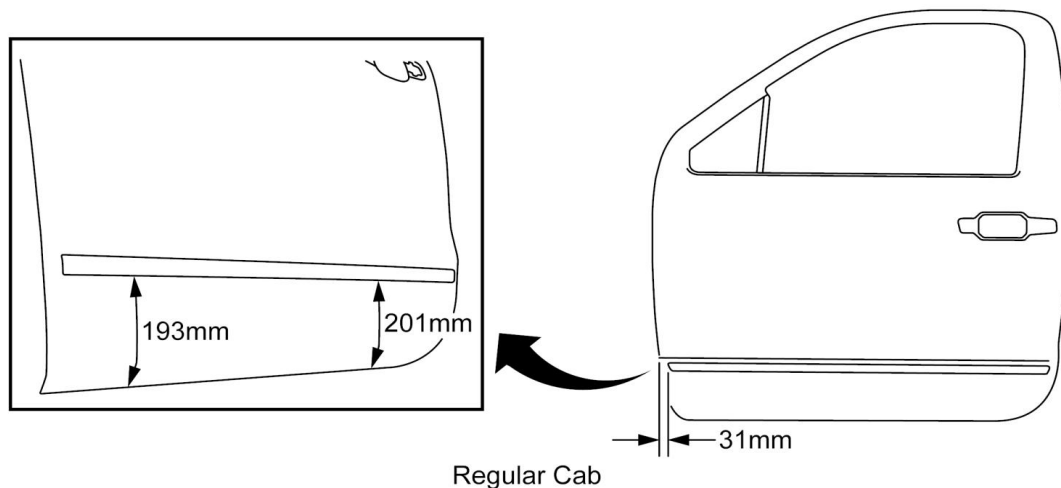

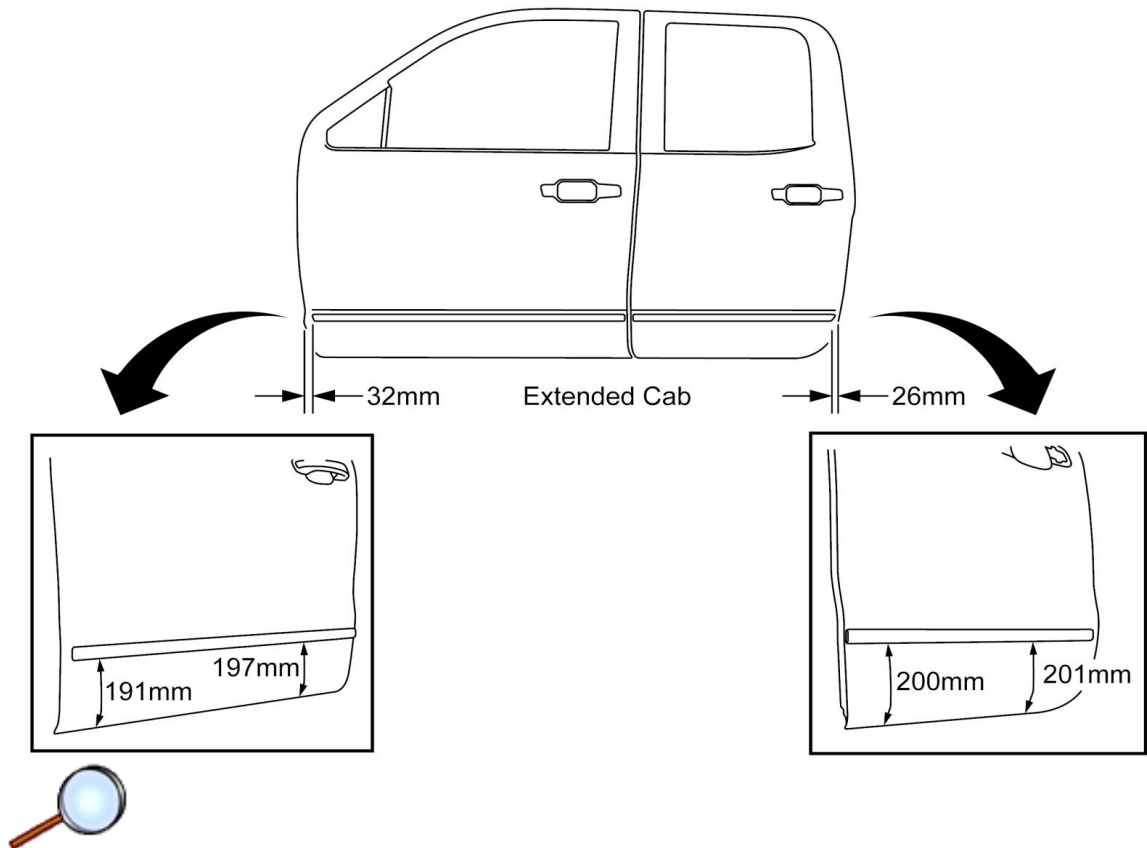
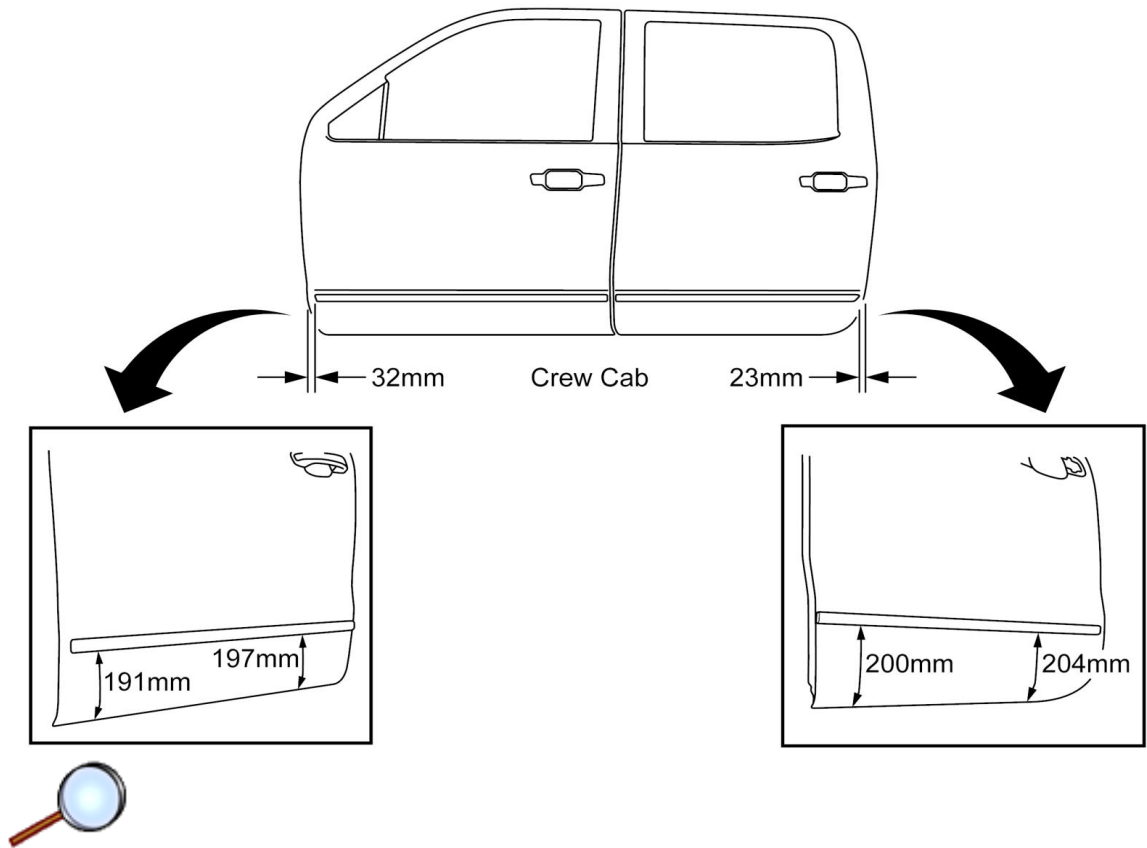

4. Measure from the door feature line as shown in illustrations and mark the door with masking tape guides.
5. Apply the adhesive molding to the left side front door, using the palm of the hand, wet out the door molding to ensure full adhesion is made.

6. Repeat steps 1-5 for right side front of the vehicle.
7. Repeat steps 1-5 for left and right side rear door (Crew cab, extended cab).