

# Rear End Spoiler Package Installation (Instruction P/N 23475090)

## [Installation Instructions Part Number](#)

23475090

### Kit Contents

Qty	Description
1	Spoiler
6	Hex Flange Nut (M6)
1	Drill Template
2	Solvent Pad
1	Installation Instructions

## [Tools Required](#)

- Power Drill
- Safety Glasses
- Center Punch
- Hammer
- 1/8" Drill Bit
- 13/32" Drill Bit
- 17/64" Drill Bit
- Deburr Tool
- Corrosion Inhibitor GM P/N (12371287) U.S. (10953437) Canada or equivalent
- Masking Tape
- Torque Wrench
- Ratchet
- Extension
- Socket (10mm)
- Universal Joint

## [Vehicle Preparation](#)

1. Temperature must be between 61°F-86°F (16°C-31°C).
2. Wash and thoroughly dry trunk lid
3. For best results, trunk lid should be free of damage (dents, scuffs, creases, fractures, etc).
4. Do not use petroleum based cleaning products. If a stronger cleaner is required, we recommend using 3M® general purpose adhesive cleaner (P/N 08984) with a clean cloth to

© 2014 General Motors. All rights reserved.

remove all visible contaminants (road tar, etc). It may take the use of several cloths to obtain a clean surface. It is important to replace the cloth when soiled or you will be smearing or wiping contaminants back on the vehicle. After using the adhesive cleaner, use the SOLVENT PKG-BODY SURF CLNR; (P/N 12365938 14W 0849Z 0030).

5. Place drop cloth inside trunk so that it sufficiently covers area under trunk lid.

### Spoiler Installation

**Note:**

- Paint spoiler as required.
- Prior to finishing or refinishing refer to GM4901M-D-005 Refinish Manual for recommended products. Do not combine paint systems. Refer to paint manufacturers recommendations for further information.

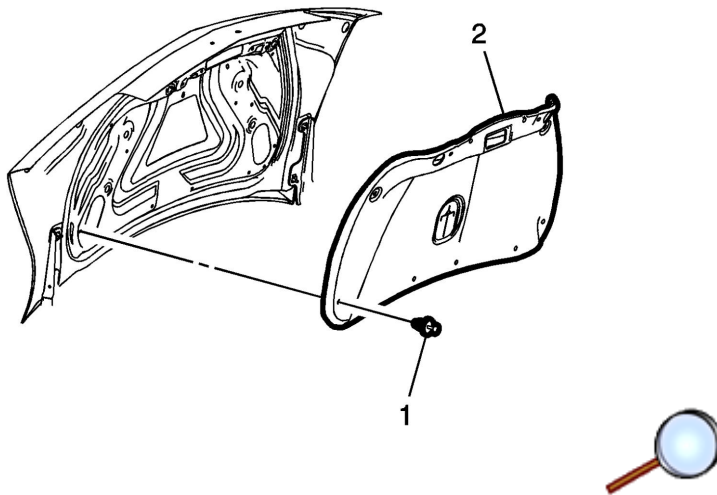

1. Remove the latch cover.
2. Remove the rear compartment lid carpet retainers (1) Qty: 11.
3. Remove the rear compartment lid carpet assembly (2). Ensure the rear compartment lid latch release cable handle is properly positioned within the opening of the rear compartment lid compartment.

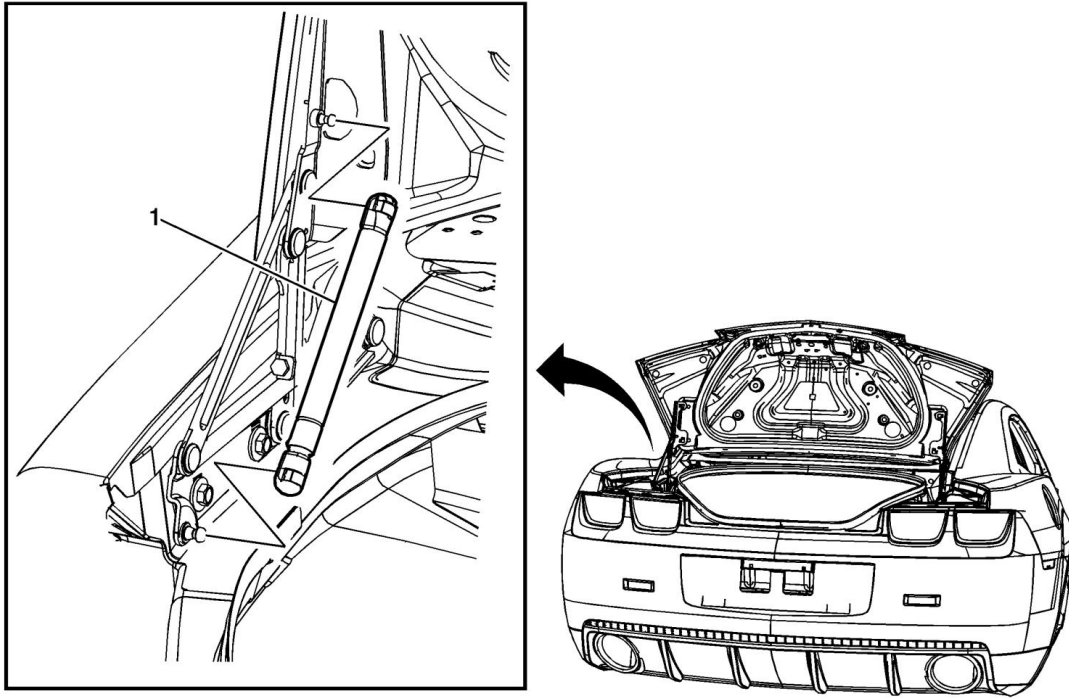

Note: This step is not necessary if there is currently a spoiler installed on the vehicle.

Warning: When a hood hold open device is being removed or installed, provide alternate support to avoid the possibility of damage to the vehicle or personal injury.

Caution: Apply pressure only at the end of the lid strut that you are removing or attaching. Do NOT apply pressure to the middle of the rod because damage or bending will result.

4. Install the strut (1) to the vehicle ensuring that the retainers are fully seated.

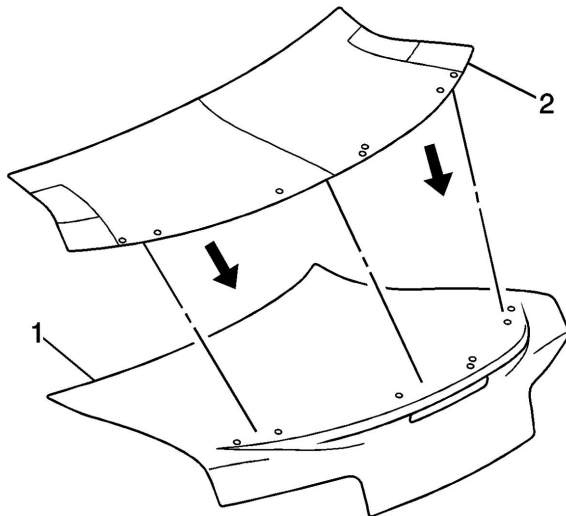

5. Position and secure holes template (2) on decklid upper surface (1).

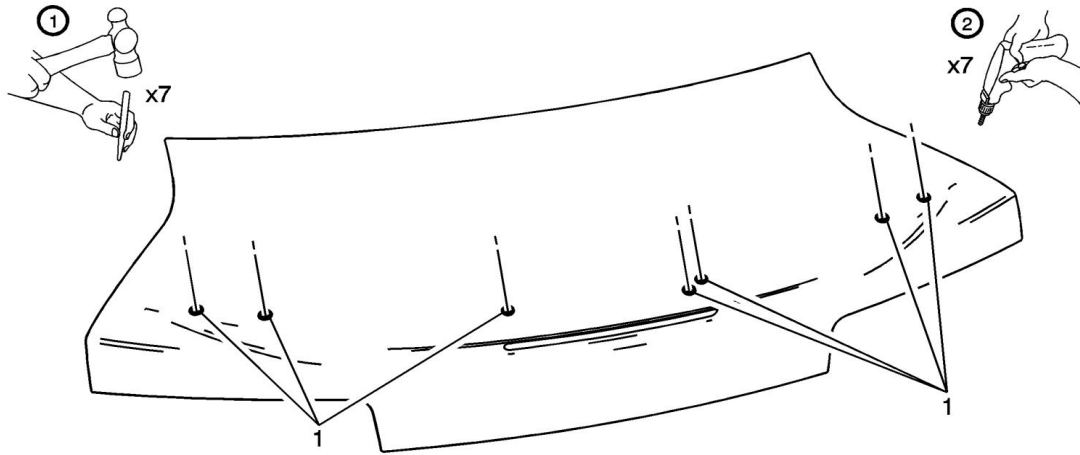

**Caution:** Always check scale, size and position of all templates before drilling. Failing to do so may cause damage to the vehicle, misalignment of components or the inability to install the accessory.

6. Center punch the marked holes (1) as located on the template.
7. Drill 1/8" pilot holes on punched locations (1).
8. Enlarge the diameter of holes according to template.

**Note:** Care should be taken during the drilling of the inner sheet metal not to damage the outer sheet.



9. Clean the decklid upper surface (1).

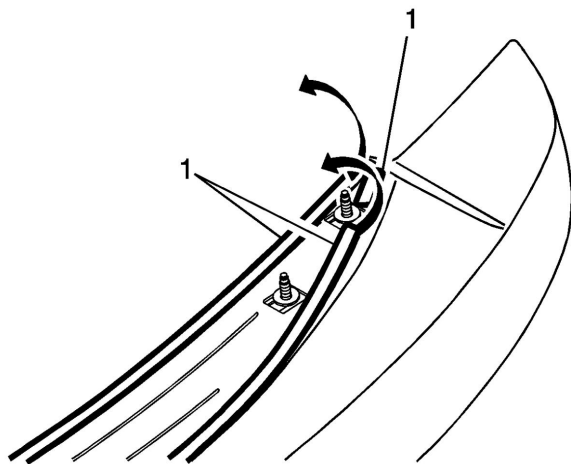

10. Remove the tape liner by using pull tabs (1).

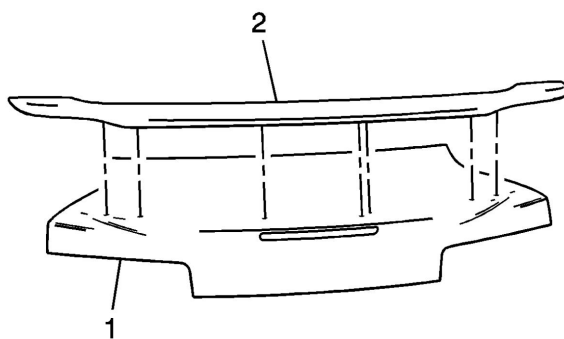

11. Place the spoiler (2) to the holes in the top of the decklid (1).

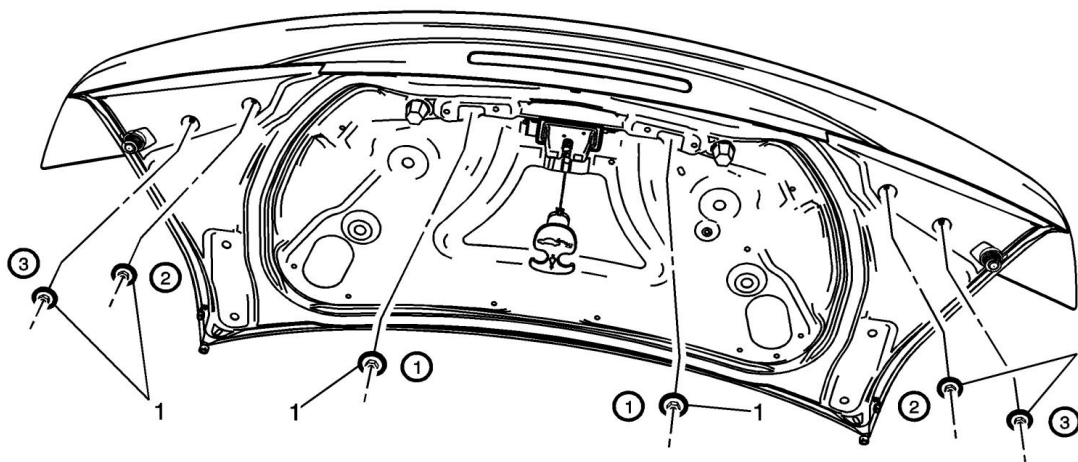

**Caution:** Use the correct fastener in the correct location. Replacement fasteners must be the correct part number for that application. Fasteners requiring replacement or fasteners requiring the use of thread locking compound or sealant are identified in the service procedure. Do not use paints, lubricants, or corrosion inhibitors on fasteners or fastener joint surfaces unless specified. These coatings affect fastener torque and joint clamping force and may damage the fastener. Use the correct tightening sequence and specifications when installing fasteners in order to avoid damage to parts and systems.

12. Secure spoiler with the supplied M6 nuts (1). Torque to sequence as indicated.  
Tighen  
Tighten the M6 nuts to 9 N.m (6.6 lb ft).

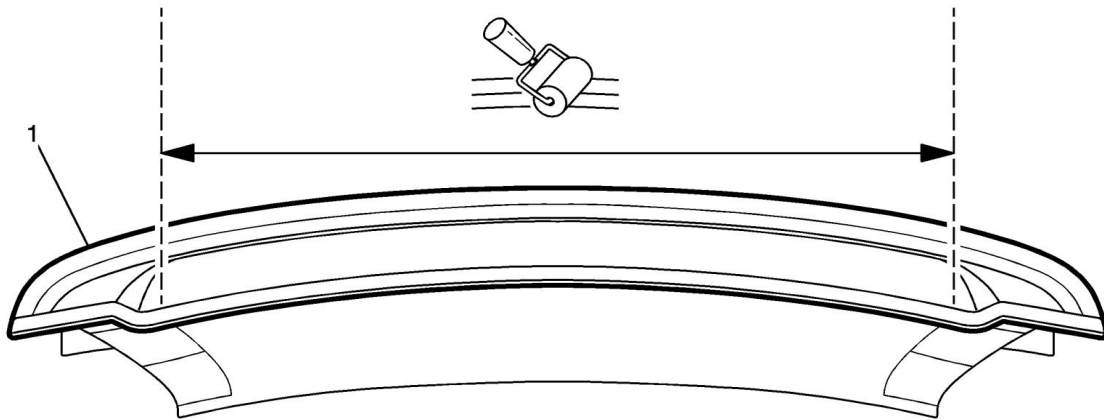

13. With the recommended usage of a rubber roller, apply 15PSI or equal pressure along the entire perimeter of the spoiler (1) to ensure good adhesion.

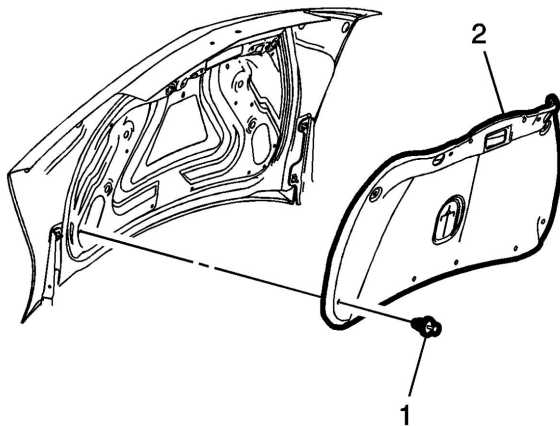

14. Install the rear compartment lid carpet assembly (2). Ensure the rear compartment lid latch release cable handle is properly positioned within the opening of the rear compartment lid compartment.
15. Install the rear compartment lid carpet retainers (1) Qty: 11.
16. Install the latch cover.