

Body Stripe Package Installation (Dual Upper Stripe)

[Installation Instructions Part Number](#)

92225512

Kit Contents

Qty	Description
1	Stripe – Hood LH
1	Stripe – Hood RH
1	Stripe – R/Cmpt Lid
1	Stripe – R/End Spoiler
1	Template Sheet – (Hood)

Tools Required

- Isopropyl Alcohol
- Lint-free cloth
- Grease pencil
- “Trigger-type” spray bottle containing 3 drops liquid detergent, to 24 oz of water mix
- Plastic Squeegee

[Procedure](#)

Surface Preparation

1. The body surface should be between 70°F and 100°F.
2. The paint surface must be thoroughly washed with warm soap and water.
3. If present, heavy contamination (like tar) should be removed with Prepsol or other quality solvent.
4. Wipe the paint surface with isopropyl alcohol and flow with a dry wipe.

Stripe Alignment and Installation Hood Stripe LH

1. Find the centerline of the Hood and use a grease pencil to mark this point at the front and rear of the hood panel.
2. Cut out the paper templates.
3. Align the notches in the templates to the grease pencil marks on the front and rear edges of the hood panel and tape in place.
4. Align the inside edge of the notches in the premask with the edge of the template.
5. Follow Steps A through C as indicated in the “Standard Procedures”.
6. Lay the adhesive side of the stripe onto the saturated hood panel and slide the stripe around until the notch edges of the stripes premack aligns to the templates, while aligning the rear edge of the carrier to the rear of the hood.

Note: If the stripe does not "slide", place additional soap into the bottle.

7. Follow Steps D through F as indicated in the "Standard Procedures".

Hood Stripe RH

Follow the same preparation, alignment and application instructions as the LH Hood stripe.

Rear Compartment Lid Stripe

Note: For vehicles that have a Spoiler, the Spoiler must be removed prior to the installation of this stripe.

1. Prepare the surface. See "Surface Preparation".
2. Find the centerline at the leading edge of the decklid and use a grease pencil to mark this point.
3. Follow Steps A through C as indicated in the "Standard Procedures".
4. Lay the adhesive side of the stripe onto the saturated body panel and slide the stripe around until the front edge of the stripes blue carrier aligns to the decklid opening with the notch aligning to the centerline.

Note: If the stripe does not "slide", place additional soap into the bottle.

5. Follow Steps D through F as indicated in the "Standard Procedures".

Spoiler Stripe (if applicable)

1. Remove the Spoiler from the vehicle.
2. Install the Rear Compartment decklid stripe as outlined above.
3. Return the Spoiler into position on the rear compartment lid. Do not fasten.
4. Align the Spoiler stripe with the rear edge of the spoilers top surface and the installed rear compartment lid stripe. Use a strip of masking tape in the center of the stripe, between the two stripe portions to secure in position.
5. Lift one side of the stripe and separate the liner from the stripe up to the tape. Use scissors to trim the liner from this section of the stripe.
6. Firmly hold the edge of the stripe slightly above the surface of the Spoiler and use the squeegee to press the stripe into place, beginning at the center and working toward the end.
7. Repeat steps 5 and 6 for the opposite side of the stripe.
8. Carefully remove the carrier at 180 degrees to the surface of the vehicle.
9. Remove the Spoiler from the vehicle.
10. Beginning at the portion of the stripe that has already adhered to the Spoiler, slowly roll the stripe around the leading edge of the Spoiler, firmly pressing the stripe onto the bottom surface of the Spoiler.

Note: If the stripe has difficulty adhering, use a hair dryer to warm and soften the stripe. This will soften the stripe allow the strip to conform to the shape of the spoiler.

11. Inspect the stripe for imperfections, bubbles and/or poor adhesion along the edges. If necessary, re-press the stripe into place and remove any bubbles with a pin or needle.
12. Re-attach the Spoiler to the Rear Compartment Lid.

Standard Procedures Surfactant use

1. Place the stripe face-down on a flat surface and slowly remove the release liner.
2. Using the sprayer, set the nozzle for fine mist and thoroughly saturate the exposed adhesive side of the stripe with the soap/water mixture.
3. Use the sprayer to saturate the body panel with the soap/water mixture.

Application

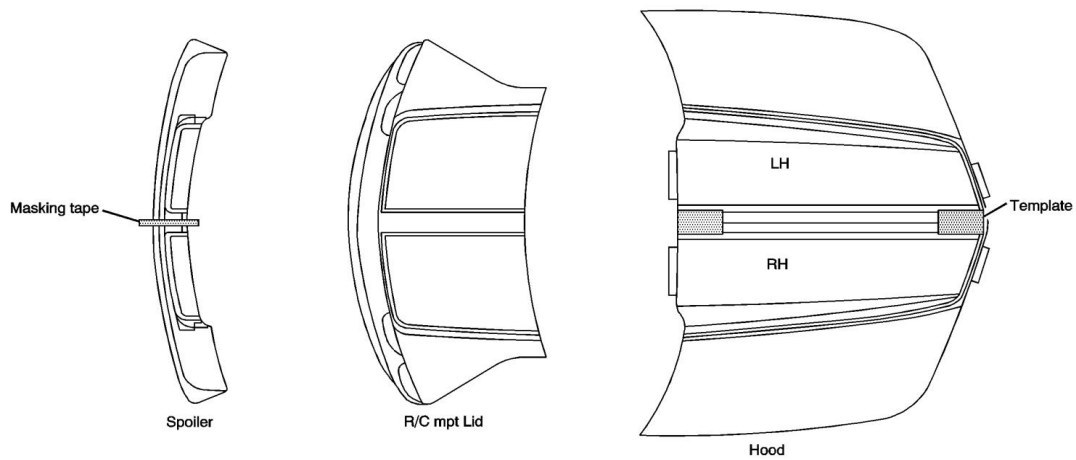

1. Using a plastic squeegee, press the stripe into place beginning at the center of the stripe while working toward the ends of the stripe.
2. Carefully remove the carrier at 180 degrees to the surface of the vehicle.
3. Inspect the stripe for imperfections, bubbles and/or poor adhesion along the edges. If necessary, re-press the stripe into place and remove any bubbles with a pin or needle.